

# NCH 250-500

1450 n [min<sup>-1</sup>]

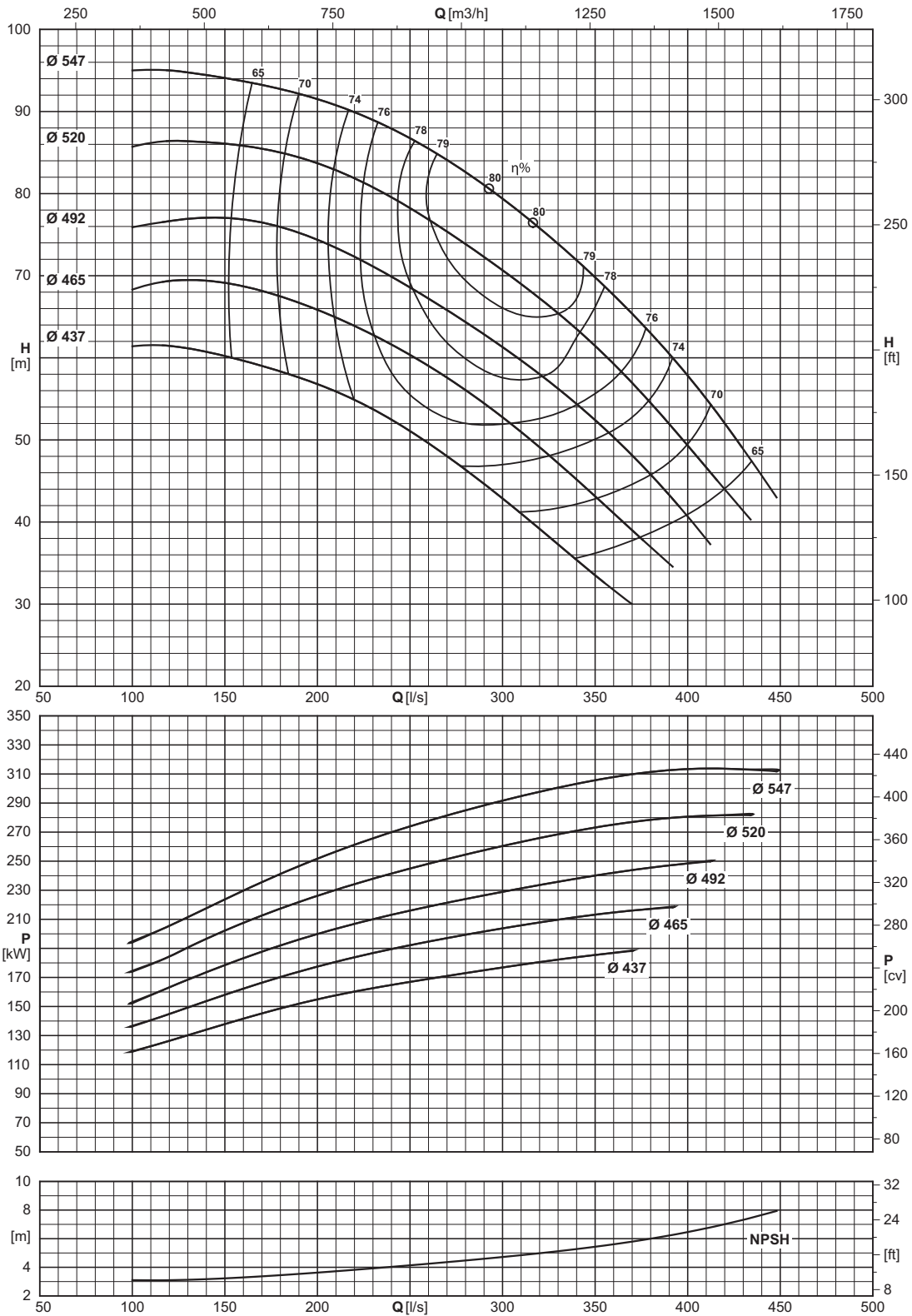

Operating data  
Caracteristiques de fonctionnement  
Caratteristiche di funzionamento



Type Type Tipo	Inlet maximum pressure (*) Pression maximale en aspiration (*) Pressione massima in aspirazione (*)	Dinamic momentum J Momentum dynamique J Momento dinamico J	
		With cast iron impellers Avec roues en fonte Con giranti in ghisa	With AISI 316 impellers Avec roues en AISI 316 Con giranti in AISI 316
		J=1/4PD <sup>2</sup>	
	[bar]	[kgm <sup>2</sup> ]	(F) 0
NCH250-500	0.5	0	(F) 0

(\*) Value referred to the impeller with maximum diameter.

(\*) Valeur se référant à la roue à ailettes avec le diamètre maximum. (\*) Valore riferito alla girante con diametro massimo.

Overall dimensions and weights  
 Dimensions d'encombement et poids  
 Dimensioni di ingombro e pesi

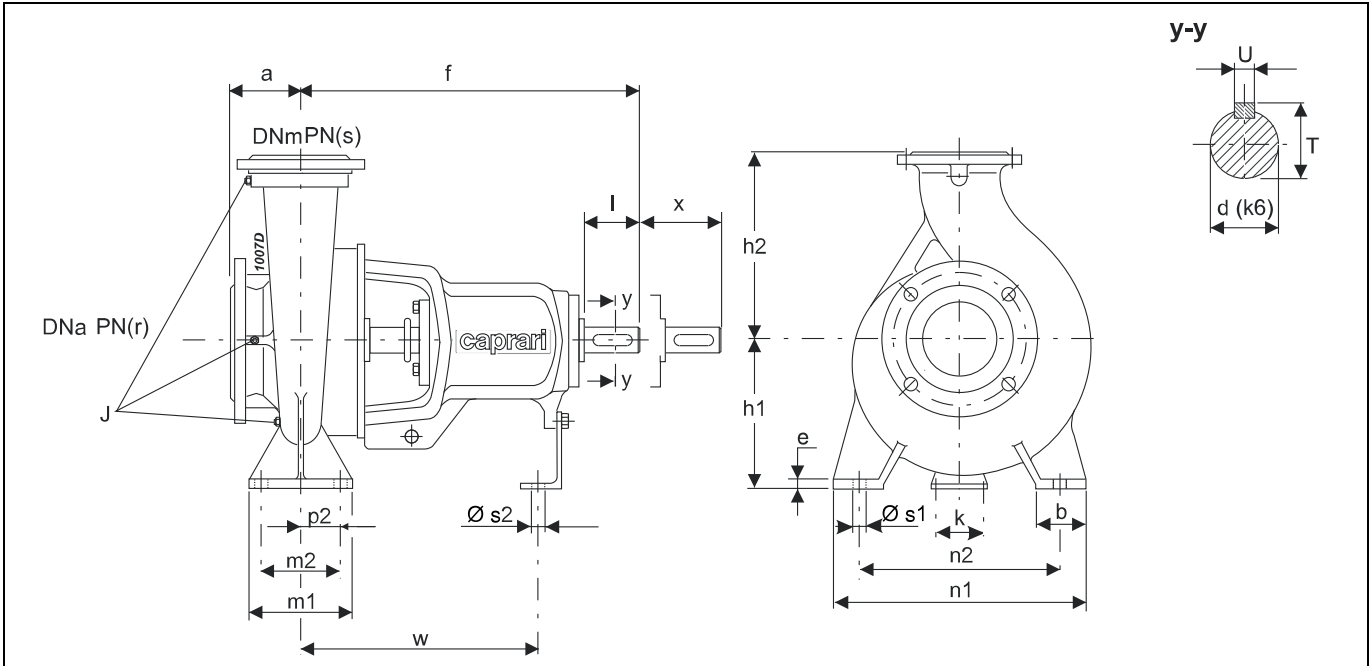

Type Type Tipo	Dimensions pump Dimensions pompe Dimensioni pompa							Duck foot pedestal dimensions Dimensiones pieds de soutien Dimensioni piedi di appoggio										Shaft projection Saillie d'arbre Sporgenza d'albero					Plugs Bouchons Tappi	Weight Poids Peso		
	DNa	DNm	r	s	a	f	h1	h2	b	e	m1	m2	p2	n1	n2	k	w	s1	s2	d	l	T	U		X	J
[mm]																										
NC100-200	125	100	16	16	125	470	200	280	80	16	160	120	-	360	280	110	340	ø 18	ø 14	32	80	35	10	140	G3/8×3. G1/4	85
NC100-250	125	100	16	16	140	470	225	280	80	16	160	120	-	400	315	110	340	ø 18	ø 14	32	80	35	10	140	G3/8×3. G3/8	106
NC100-315	125	100	16	16	140	470	250	315	80	16	160	120	-	400	315	110	340	ø 18	ø 14	32	80	35	10	140	G3/8×3. G3/8	134
NC100-400	125	100	16	16	140	530	280	355	100	18	200	150	-	500	400	110	370	ø 23	ø 14	42	110	45	12	140	G3/8×2 G1/2. G1/4	174
NCH100-315	125	100	16	16	140	530	250	315	80	19	160	120	-	400	315	110	370	ø 18	ø 14	42	110	45	12	140	G1/4×3	135
NC125-200	150	125	16	16	140	470	250	315	80	16	160	120	-	400	315	110	340	ø 18	ø 14	32	80	35	10	140	G3/8×3. G3/8	106
NC125-250	150	125	16	16	140	470	250	355	80	16	160	120	-	400	315	110	340	ø 18	ø 14	32	80	35	10	140	G3/8×3. G3/8	125
NC125-315	150	125	16	16	140	530	280	355	100	18	200	150	-	500	400	110	370	ø 23	ø 14	42	110	45	12	140	G3/8×2 G1/2. G1/4	163
NC125-400	150	125	16	16	140	530	315	400	100	18	200	150	-	500	400	110	370	ø 23	ø 14	42	110	45	12	140	G3/8×2 G1/2. G1/4	191
NCH125-250	150	125	16	16	140	530	250	355	80	19	160	120	-	400	315	110	370	ø 18	ø 14	42	110	45	12	140	G1/4×3	140
NCH125-400	150	125	16	16	140	530	315	400	100	21	200	150	-	500	400	110	370	ø 18	ø 14	42	110	45	12	140	G1/4×3	186
NCH125-500	150	125	16	16	160	670	355	450	100	25	200	150	-	550	450	140	500	ø 23	ø 18	48	110	51,5	14	180	G1/4×3	359
NC150-200	200	150	16	16	160	495	280	400	100	20	200	150	-	550	450	110	370	ø 23	ø 14	32	80	35	10	180	G3/8×3. G1/4	181
NC150-250	200	150	16	16	160	530	250	355	100	18	200	150	-	450	350	110	370	ø 23	ø 14	42	110	45	12	140	G1/4. G3/8×2 G1/2. G3/8	148
NC150-315	200	150	16	16	160	530	280	400	100	18	200	150	-	550	450	110	370	ø 23	ø 14	42	110	45	12	140	G1/4×3	170
NC150-400	200	150	16	16	160	530	315	450	100	18	200	150	-	550	450	110	370	ø 23	ø 14	42	110	45	12	140	G3/8×2 G1/2. G1/4	209
NCH150-500	200	150	16	16	160	670	400	500	100	25	200	150	60	550	450	140	480	ø 23	ø 18	60	140	64	18	180	G3/8×3	410
NC200-250	250	200	16	16	180	553	315	450	100	20	200	150	-	550	450	110	393	ø 28	ø 14	42	110	45	12	180	G3/8×2 G1/2. G3/8	220
NC200-315	250	200	16	16	180	670	315	480	120	20	220	170	-	600	480	110	504	ø 28	ø 14	48	110	51	14	180	G3/8×3. G3/8	251
NC200-400	250	200	16	16	180	670	335	480	120	20	220	170	-	600	480	110	504	ø 28	ø 14	48	110	51	14	180	G3/8×3. G3/8	295
NCH200-500	250	200	16	16	225	885	400	580	150	28	315	250	-	760	630	180	670	ø 28	ø 18	65	140	69	18	250	G3/8×3	577
NC250-315	300	250	16	16	220	691	355	520	150	22	250	200	-	660	510	110	525	ø 28	ø 14	48	110	51	14	180	G3/8×3. G3/8	311
NC250-400	300	250	16	16	220	682	400	560	150	22	250	200	-	660	510	110	516	ø 28	ø 14	48	110	51	14	180	G3/8×3. G3/8	390
NCH250-250	300	250	16	16	225	885	355	560	125	24	250	190	-	630	500	180	670	ø 23	ø 18	65	140	69	18	250	G3/8×3	434
NCH250-500	300	250	16	16	225	885	450	630	150	28	315	250	-	760	630	180	670	ø 28	ø 18	65	140	69	18	250	G3/8×3	670
NCHF250-500	300	250	16	16	225	885	450	630	150	28	315	250	-	760	630	180	670	ø 28	ø 18	65	140	69	18	250	G3/8×3	670

Selection - dimensions and weights for base mounted electric pumps  
 Sélection - dimensions et poids des électropompes sur socle  
 Selezione - dimensioni e pesi elettropompe su base

COUPLINGS WITH STANDARDIZED ENCLOSED ELECTRIC MOTORS  
 ACCOUPLEMENTS AVEC MOTEURS ÉLECTRIQUES FERMÉS NORMALISÉS  
 ACCOPIAMENTI CON MOTORI ELETTRICI CHIUSI NORMALIZZATI

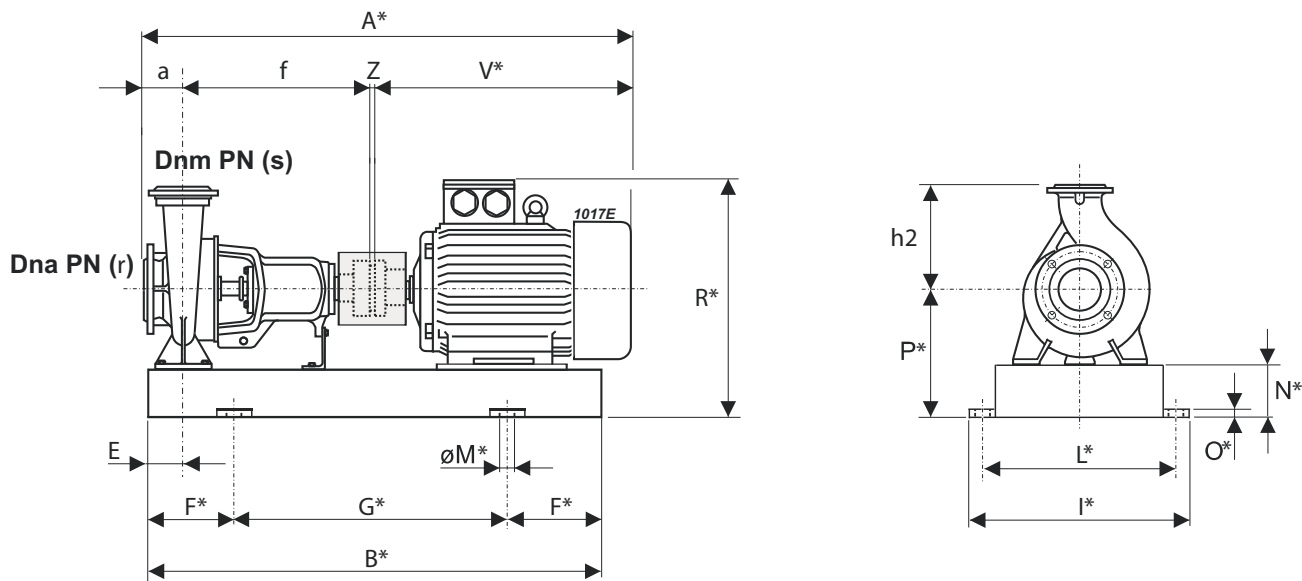

Pump Pompe Pompa			Motor Moteur Motore		BGAN	A	B	E	F	G	I	L	M	N	O	P	R	V	Z	a	f	h2	r	s	Weight Poids Peso	
Type Type Tipo	DNa [mm]	DNm [mm]	[kW]	Size Taille Grand.	Type Type Tipo	[mm]																				[kg]
NC200-250	250	200	30	200L	1108/GY	1495	1305	110	200	905	680	630	ø 22	160	50	475	775	758	4	180	553	450	16	16	621	
NC200-250	250	200	37	225S	1109/GY	1530	1308	110	200	908	680	630	ø 22	160	50	475	805	793	4	180	553	450	16	16	694	
NC200-250	250	200	45	225M	1141/HY	1555	1333	110	200	933	680	630	ø 22	160	50	475	805	818	4	180	553	450	16	16	703	
NC200-250	250	200	55	250M	1110/HY	1617	1385	110	250	885	680	630	ø 22	160	50	475	850	880	4	180	553	450	16	16	819	
NC200-315	250	200	30	200L	1111/GY2	1612	1432	120	250	932	730	680	ø 22	160	50	475	775	758	4	180	670	480	16	16	664	
NC200-315	250	200	37	225S	1112/GY2	1647	1435	120	250	935	730	680	ø 22	160	50	475	805	793	4	180	670	480	16	16	740	
NC200-315	250	200	45	225M	1113/HY2	1672	1460	120	250	960	730	680	ø 22	160	50	475	805	818	4	180	670	480	16	16	776	
NC200-315	250	200	55	250M	1114/HY2	1734	1512	120	250	1012	730	680	ø 22	160	50	475	850	880	4	180	670	480	16	16	861	
NC200-315	250	200	75	280S	1115/IY2	1867	1559	120	250	1059	730	680	ø 22	160	50	475	870	1013	4	180	670	480	16	16	926	
NC200-400	250	200	75	280S	1116/IY2	1867	1584	145	250	1084	730	680	ø 22	160	50	495	890	1013	4	180	670	480	16	16	963	
NC200-400	250	200	90	280M	1117/IY2	1918	1635	145	250	1135	730	680	ø 22	160	50	495	890	1064	4	180	670	480	16	16	1166	
NC200-400	250	200	110	315S	1118/LY2	2065	1711	145	300	1111	780	730	ø 22	160	50	495	1050	1211	4	180	670	480	16	16	1250	
NC200-400	250	200	132	315M	1120/LY2	2175	1770	145	300	1170	780	730	ø 22	160	50	495	1050	1321	4	180	670	480	16	16	1395	
NCH200-500	250	200	90	280M	2027/IY4	2178	1885	170	300	1285	890	840	ø 22	200	50	600	995	1064	4	225	885	580	16	16	1489	
NCH200-500	250	200	110	315S	2028/LY4	2325	1961	170	350	1261	890	840	ø 22	200	50	600	1155	1211	4	225	885	580	16	16	1701	
NCH200-500	250	200	132	315M	2029/LY4	2435	2071	170	350	1371	890	840	ø 22	200	50	600	1155	1321	4	225	885	580	16	16	1815	
NCH200-500	250	200	160	315L	2029/MY5	2435	2071	170	350	1371	890	840	ø 22	200	50	600	1155	1321	4	225	885	580	16	16	1965	
NCH200-500	250	200	200	315L	2029/IE4/MY5	2525	2161	170	350	1461	890	840	ø 22	200	50	600	1155	1411	4	225	885	580	16	16	2030	
NCH200-500	250	200	250	355M	2026/NY5	2670	2215	170	350	1515	890	840	ø 22	200	50	600	1201	1556	4	225	885	580	16	16	2442	
NCH200-500	250	200	315	355L	2026/PY5	2670	2215	170	350	1515	890	840	ø 22	200	50	600	1201	1556	4	225	885	580	16	16	2632	
NC250-315	300	250	30	200L	1142/GY2	1673	1488	135	250	988	790	740	ø 22	180	50	535	835	758	4	220	691	520	16	16	776	
NC250-315	300	250	37	225S	1143/GY2	1708	1505	135	250	1005	790	740	ø 22	180	50	535	865	793	4	220	691	520	16	16	809	
NC250-315	300	250	45	225M	1144/HY2	1733	1530	135	250	1030	790	740	ø 22	180	50	535	865	818	4	220	691	520	16	16	854	
NC250-315	300	250	55	250M	1145/HY2	1795	1558	135	250	1058	790	740	ø 22	180	50	535	910	880	4	220	691	520	16	16	1025	
NC250-315	300	250	75	280S	1146/IY2	1928	1605	135	250	1105	790	740	ø 22	180	50	535	930	1013	4	220	691	520	16	16	946	
NC250-400	300	250	75	280S	1147/IY2	1919	1596	135	250	1096	790	740	ø 22	200	50	600	995	1013	4	220	682	560	16	16	1207	
NC250-400	300	250	90	280M	1148/IY2	1970	1647	135	250	1147	790	740	ø 22	200	50	600	995	1064	4	220	682	560	16	16	1213	
NC250-400	300	250	110	315S	1149/LY2	2117	1723	135	300	1123	790	740	ø 22	200	50	600	1155	1211	4	220	682	560	16	16	1499	
NC250-400	300	250	132	315M	1119/LY2	2227	1833	135	300	1233	790	740	ø 22	200	50	600	1155	1321	4	220	682	560	16	16	1500	
NC250-400	300	250	160	315L	1119/LY2	2227	1833	135	300	1233	790	740	ø 22	200	50	600	1155	1321	4	220	682	560	16	16	1650	
NC250-400	300	250	200	315L	1119/IE4/LY2	2317	1923	135	300	1323	790	740	ø 22	200	50	600	1155	1411	4	220	682	560	16	16	1806	
NCH250-250	300	250	75	280S	2054/IY4	2127	1799	135	300	1199	760	710	ø 22	180	50	535	930	1013	4	225	885	560	16	16	1136	
NCH250-500	300	250	160	315L	2024/MY5	2435	2071	170	350	1371	890	840	ø 22	220	50	670	1225	1321	4	225	885	630	16	16	2075	
NCH250-500	300	250	200	315L	2024/IE4/MY5	2525	2161	170	350	1461	890	840	ø 22	220	50	670	1225	1411	4	225	885	630	16	16	2163	
NCH250-500	300	250	250	355M	2040/NY5	2670	2165	170	350	1465	890	840	ø 22	220	50	670	1271	1556	4	225	885	630	16	16	2605	
NCH250-500	300	250	315	355L	2040/PY5	2670	2235	170	350	1535	890	840	ø 22	220	50	670	1271	1556	4	225	885	630	16	16	2795	
NCH250-500	300	250	355	355L	2040/PY5	2670	2235	170	350	1535	890	840	ø 22	220	50	670	1271	1556	4	225	885	630	16	16	2810	

BGAN = Base and coupling  
 \* = Indicatives values according to the type of motor installed.

BGAN = Socle et accouplement  
 \* = Valeurs indicatives en fonction de la marque du moteur utilisé.

BGAN = Base e giunto  
 \* = Valori indicativi in funzione della marca di motore utilizzato.

○ Motor in IE4 efficiency class according to EU REGULATION 2019/1781. Available in other efficiency classes for non-EU markets.

○ Moteur en classe de rendement IE4 conformément au RÈGLEMENT UE2019/1781. Disponibilité en différentes classes de rendement pour les marchés hors UE.

○ Motore in classe di efficienza IE4 in conformità al REGOLAMENTO UE2019/1781. Disponibili in altre classi di efficienza per mercati extra UE.

Selection - dimensions and weights for base mounted electric pumps  
 Sélection - dimensions et poids des électropompes sur socle  
 Selezione - dimensioni e pesi elettropompe su base

COUPLINGS WITH STANDARDIZED ENCLOSED ELECTRIC MOTORS  
 ACCOUPLEMENTS AVEC MOTEURS ÉLECTRIQUES FERMÉS NORMALISÉS  
 ACCOPIAMENTI CON MOTORI ELETTRICI CHIUSI NORMALIZZATI

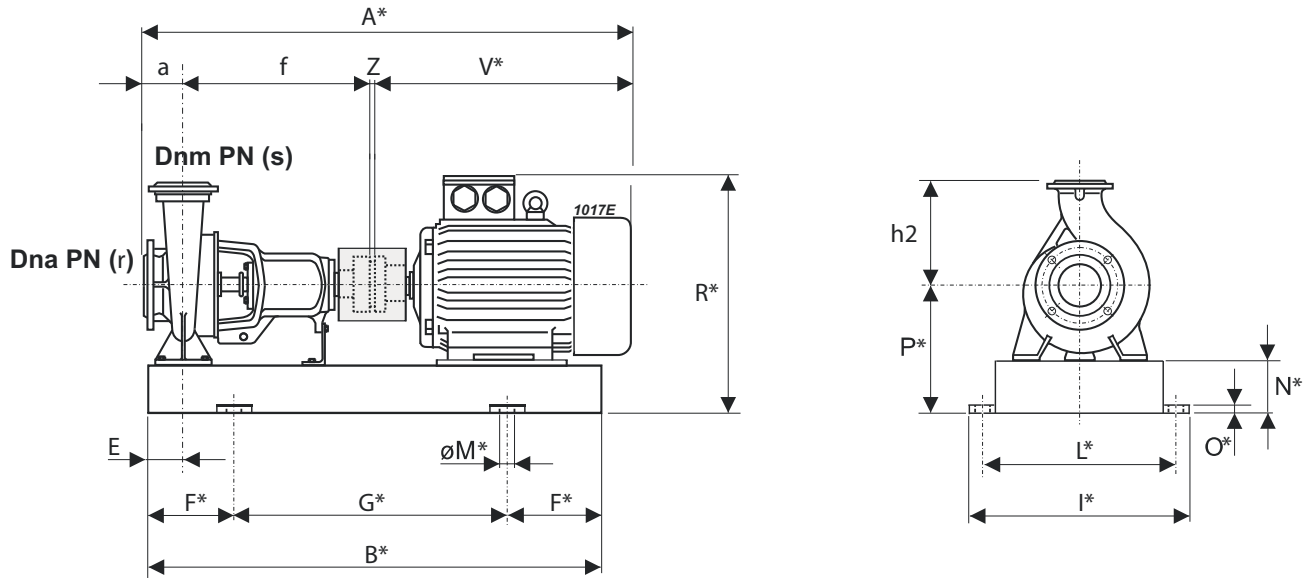

Pump Pompe Pompa			Motor Moteur Motore		BGAN	A*	B*	E	F*	G*	I*	L*	M*	N*	O*	P*	R*	V*	Z	a	f	h2	r	s	Weight Poids Peso	
Type Type Tipo	DNa [mm]	DNm [mm]	[kW]	Size Taille Grand.	Type Type Tipo	[mm]																				
NCH125-400	150	125	11	160L	2045/EY3	1301	1161	110	200	761	630	580	ø 22	160	50	475	726	627	4	140	530	400	16	16	428	
NCH125-400	150	125	15	180L	2046/FY3	1379	1209	110	200	809	630	580	ø 22	160	50	475	745	705	4	140	530	400	16	16	482	
NCH125-400	150	125	18,5	200L	2048/FY3	1432	1282	110	200	882	630	580	ø 22	160	50	475	775	758	4	140	530	400	16	16	524	
NCH125-400	150	125	22	200L	2048/GY3	1432	1282	110	200	882	630	580	ø 22	160	50	475	775	758	4	140	530	400	16	16	540	
NCH125-400	150	125	30	225M	2049/HY4	1492	1310	110	200	910	630	580	ø 22	160	50	475	805	818	4	140	530	400	16	16	659	
NCH125-500	150	125	15	180L	2038/FY3	1539	1404	110	250	904	680	630	ø 22	180	50	535	805	705	4	160	670	450	16	16	700	
NCH125-500	150	125	18,5	200L	2039/FY3	1592	1442	110	250	942	680	630	ø 22	180	50	535	835	758	4	160	670	450	16	16	740	
NCH125-500	150	125	22	200L	2039/GY3	1592	1442	110	250	942	680	630	ø 22	180	50	535	835	758	4	160	670	450	16	16	756	
NCH125-500	150	125	30	225M	2034/HY4	1652	1484	110	250	984	680	630	ø 22	180	50	535	865	818	4	160	670	450	16	16	837	
NCH125-500	150	125	37	250M	2033/HY4	1714	1512	110	250	1012	680	630	ø 22	180	50	535	910	880	4	160	670	450	16	16	907	
NCH125-500	150	125	45	280S	2035/IY4	1854	1559	110	250	1059	680	630	ø 22	180	50	535	925	1020	4	160	670	450	16	16	1090	
NCH200-500	250	200	30	225M	2031/HY4	1932	1779	170	300	1179	890	840	ø 22	200	50	600	930	818	4	225	885	580	16	16	1103	
NCH200-500	250	200	37	250M	2032/HY4	1994	1836	170	300	1236	890	840	ø 22	200	50	600	975	880	4	225	885	580	16	16	1161	
NCH200-500	250	200	45	280S	2030/IY4	2134	1834	170	300	1234	890	840	ø 22	200	50	600	990	1020	4	225	885	580	16	16	1398	
NCH200-500	250	200	55	280M	2027/IY4	2184	1885	170	300	1285	890	840	ø 22	200	50	600	990	1070	4	225	885	580	16	16	1481	
NCH200-500	250	200	75	315S	2028/LY4	2325	1961	170	350	1261	890	840	ø 22	200	50	600	1155	1211	4	225	885	580	16	16	1686	
NCH200-500	250	200	90	315M	2029/LY4	2435	2071	170	350	1371	890	840	ø 22	200	50	600	1155	1321	4	225	885	580	16	16	1815	
NCH250-250	300	250	18,5	200L	2055/HY4	1872	1682	135	300	1082	760	710	ø 22	180	50	535	835	758	4	225	885	560	16	16	721	
NCH250-250	300	250	22	200L	2055/HY4	1872	1682	135	300	1082	760	710	ø 22	180	50	535	835	758	4	225	885	560	16	16	737	
NCH250-500	300	250	45	280S	2042/IY4	2134	1887	170	300	1287	890	840	ø 22	220	50	670	1060	1020	4	225	885	630	16	16	1451	
NCH250-500	300	250	55	280M	2043/IY4	2184	1938	170	300	1338	890	840	ø 22	220	50	670	1060	1070	4	225	885	630	16	16	1535	
NCH250-500	300	250	75	315S	2044/LY4	2325	1961	170	350	1261	890	840	ø 22	220	50	670	1225	1211	4	225	885	630	16	16	1812	
NCH250-500	300	250	90	315M	2041/LY4	2435	2071	170	350	1320	890	840	ø 22	220	50	670	1225	1321	4	225	885	630	16	16	1925	
NCH250-500	300	250	110	315L	2024/MY5	2435	2071	170	350	1371	890	840	ø 22	220	50	670	1225	1321	4	225	885	630	16	16	1995	
NCHF250-500	300	250	45	280S	2042/IY4	2134	1887	170	300	1287	890	840	ø 22	220	50	670	1060	1020	4	225	885	630	16	16	1241	
NCHF250-500	300	250	55	280M	2043/IY4	2184	1938	170	300	1338	890	840	ø 22	220	50	670	1060	1070	4	225	885	630	16	16	1325	
NCHF250-500	300	250	75	315S	2044/LY4	2325	1961	170	350	1261	890	840	ø 22	220	50	670	1225	1211	4	225	885	630	16	16	1812	
NCHF250-500	300	250	90	315M	2041/LY4	2435	2071	170	350	1320	890	840	ø 22	220	50	670	1225	1321	4	225	885	630	16	16	1925	
NCHF250-500	300	250	110	315L	2024/MY5	2435	2071	170	350	1371	890	840	ø 22	220	50	670	1225	1321	4	225	885	630	16	16	1995	

BGAN = Base and coupling      BGAN = Socle et accouplement      BGAN = Base e giunto  
 \* = Indicatives values according to the type of motor installed.      \* = Valeurs indicatives en fonction de la marque du moteur utilisé.      \* = Valori indicativi in funzione della marca di motore utilizzato.  
 ○ Motor in IE4 efficiency class according to EU REGULATION      ○ Moteur en classe de rendement IE4 conformément au RÈGLEM-      ○ Motore in classe di efficienza IE4 in conformità al REGOLAMENTO  
 2019/1781. Available in other efficiency classes for non-EU mar-      ENT UE2019/1781. Disponibilit  en diff rentes classes de rende-      UE2019/1781. Disponibili in altre classi di efficienza per mercati extra  
 kets.      ment pour les march s hors UE.      UE.