

Utilization field Champ d'utilisation Campo di utilizzo ≥ 67% η		
Stage number: compatibly with the maximum pressure. Nombre d'étages: compatible avec la pression maximum. Numero stadi: compatibilmente con la pressione massima di esercizio.		
Type Type Tipo	MIN.	MAX.
PML	2	8
PMLS	2	8
NB. For two-stage pumps only, reduce efficiency by one point. Diminuer le rendement d'un point seulement pour les pompes à deux étages. Solamente per le pompe a due stadi, ridurre di un punto il rendimento.		

Wet moment of inertia J Moment d'inertie J mouillé Momento d'inertzia J bagnato $J = \frac{1}{4}PD^2$ - [kg m <sup>2</sup> ]		
Impeller type Roue type Girante tipo	PML(S)150/1	For each additional stage Pour chaque étage en plus Per ogni stadio in più
Cast iron Fonte Ghisa	0,181	0,154
Bronze Bronzo	0,197	0,169

Maximum permissible power Puissances maximums admissibles Massime potenze ammissibili	
Type / Type / Tipo	N/n MAX.
PML	0,24
PMLS	0,24
For seal limits and calculation formulas of the maximum permissible powers, see technical data section. Consulter la section Données techniques pour connaître les limites des joints et les formules pour le calcul des puissances maximales admises. Per i limiti tenute e le formule di calcolo delle massime potenze ammissibili, vedere sezione dati tecnici.	

PERFORMANCES EACH INTERMEDIATE STAGE  
CARACTERISTIQUES POUR CHAQUE ETAGE  
PRESTAZIONI PER STADIO

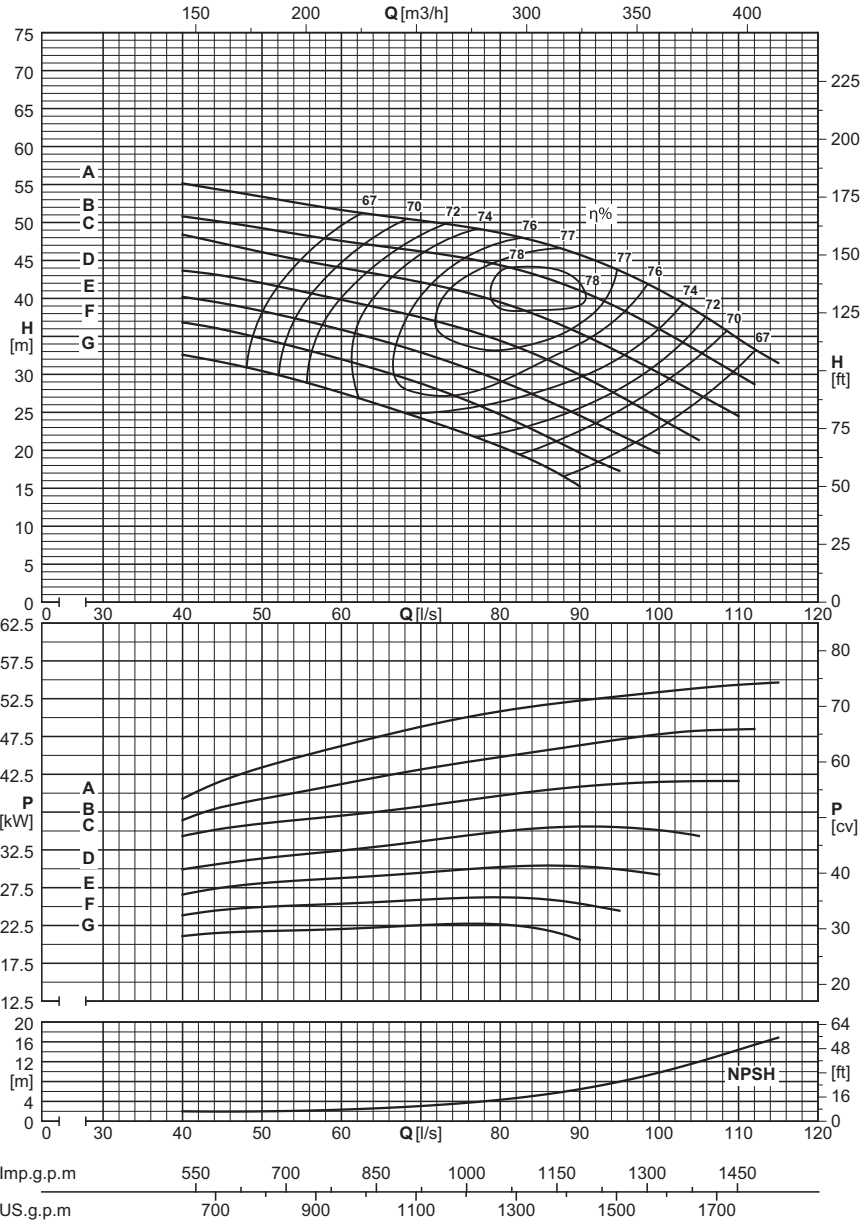

		Capacity - Débit - Portata																				
Dna x Dnm	Impeller type Roue type Girante tipo	[l/s]	0	48	52	56	60	64	68	72	76	80	84	88	92	96	100	104	108	112		
		[m <sup>3</sup> /h]	0	172,8	187,2	201,6	216	230,4	244,8	259,2	273,6	288	302,4	316,8	331,2	345,6	360	374,4	388,8	403,2		
		[l/min]	0	2880	3120	3360	3600	3840	4080	4320	4560	4800	5040	5280	5520	5760	6000	6240	6480	6720		
PML(S)150/1																						
200x150	G	[m]	38,5	31	30,5	28,5	27,5	26	25	23,5	22	20,5	18,5	17	15							
200x150	G	[kW]		21,5	21,5	22	21,5	22,5	22	22,5	22,5	23	22	21,5	21							
200x150	F	[m]	42,5	35,5	34,5	33,5	32	30,5	29,5	28	26,5	24,5	23	20,5	18,5	17						
200x150	F	[kW]		24,5	25	24,5	25,5	26	25,5	26	26,5	26,5	25	25,5	24,5							
200x150	E	[m]	46	39,5	38	37	35,5	35	33,5	32	30,5	29	27,5	25,5	24	21,5	19,5					
200x150	E	[kW]		27	29	28,5	29	28,5	29	30	30,5	30	30,5	30,5	31	29,5	29					
200x150	D	[m]	50		42,5	41,5	40	39	38	36,5	36,5	34,5	33	31	30	27,5	23,5	21,5	21			
200x150	D	[kW]			31	31,5	32	33	33,5	34,5	34	34,5	35	35,5	36	36,5	34,5	34,5	35,5			
200x150	C	[m]	55			44,5	43	44	43	42	41	39,5	38	36,5	34,5	32,5	30,5	28,5	26			
200x150	C	[kW]				37,5	38	36,5	37,5	38	39	39,5	40	40,5	41	41,5	42	42	42,5			
200x150	B	[m]	61				47,5	47	46,5	45,5	45	44,5	45	43,5	42	40	38	36	33,5	31	28,5	
200x150	B	[kW]					41	41,5	42,5	43,5	44	45,5	44	45	45,5	46,5	47,5	47,5	49	48,5	48,5	
200x150	A	[m]	70					51	50	50	49,5	49	48,5	47,5	46,5	45	43	41	40	36,5	33,5	
200x150	A	[kW]						46,5	47,5	48,5	49,5	50,5	51	51,5	52,5	53	53,5	53,5	54	54,5	55	
NPSH																						
		[m]		2	2	2,2	2,3	2,6	2,9	3,3	3,7	4,3	5,1	5,9	7	8,1	9,8	11,7	13,5	15,4		

Overall dimensions and weights  
 Dimensions d'encombrement et poids  
 Dimensioni di ingombro e pesi

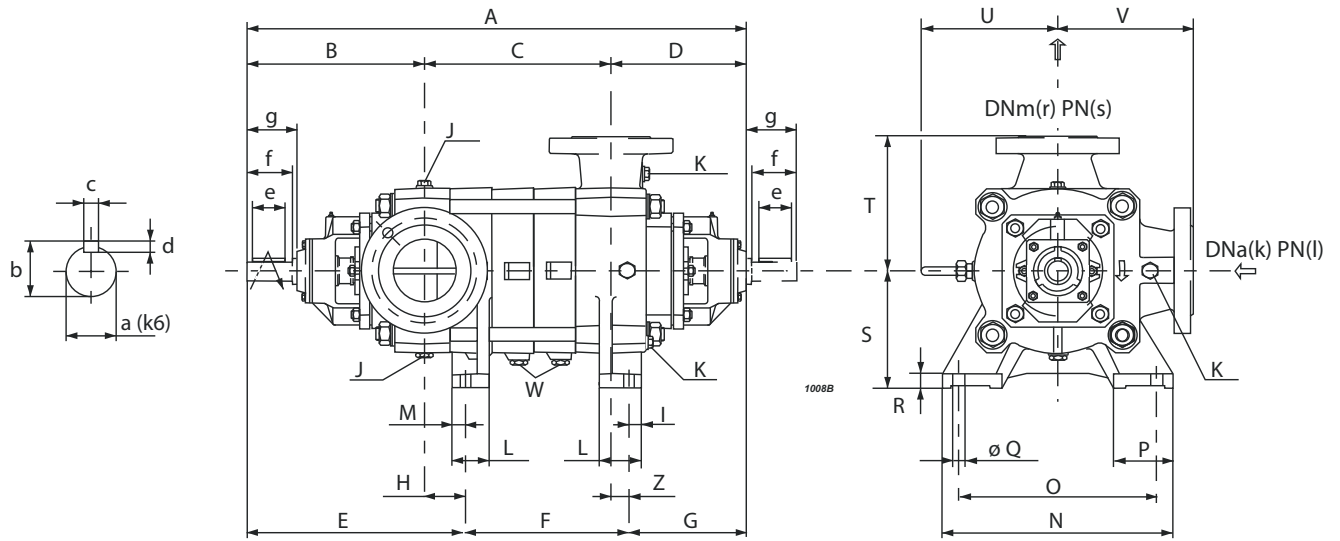

Series Série Serie	Type Type Tipo	A	B	C	D	E	F	G	H	S	T	U	V	Z	Weight Poids Peso
		[mm]													[kg]
PML(S)	150/2	1190	479	360	351	619	270	301	140	315	370	358	370	50	652
PML(S)	150/3	1315	479	485	351	619	395	301	140	315	370	358	370	50	726
PML(S)	150/4	1440	479	610	351	619	520	301	140	315	370	358	370	50	800
PML(S)	150/5	1565	479	735	351	619	645	301	140	315	370	358	370	50	874
PML(S)	150/6	1690	479	860	351	619	770	301	140	315	370	358	370	50	948
PML(S)	150/7	1815	479	985	351	619	895	301	140	315	370	358	370	50	1022
PML(S)	150/8	1940	479	1110	351	619	1020	301	140	315	370	358	370	50	1096
PML(S)	150/9	2065	479	1235	351	619	1145	301	140	315	370	358	370	50	1170
PML(S)	150/10	2190	479	1360	351	619	1270	301	140	315	370	358	370	50	1244

Foot dimensions Dimensions des pieds Dimensioni dei piedi							
I	L	M	N	O	P	Q	R
[mm]							
43	125	45	680	590	170	24	40

Shaft projection Saille d'arbre Sporgenza d'albero						
a	b	c	d	e	f	g
[mm]						
55	59	16	10	120	130	145

Type Type Tipo	Flanges Brides Flange			
	(k) DNa	(l) PN	(r) DNm	(s) PN
	[mm]	[bar]	[mm]	[bar]
PML	200	25	150	40
PMLS	200	25	150	63

Plugs Bouchons Tappi		
J	K	W
G3/4	G1/2	G1/4

Selection - dimensions and weights for base mounted electric pumps  
 Sélection - dimensions et poids des électropompes sur socle  
 Selezione - dimensioni e pesi elettropompe su base

COUPLINGS WITH STANDARDIZED ENCLOSED ELECTRIC MOTORS  
 ACCOUPLEMENTS AVEC MOTEURS ÉLECTRIQUES FERMÉS NORMALISÉS  
 ACCOPIAMENTI CON MOTORI ELETTRICI CHIUSI NORMALIZZATI

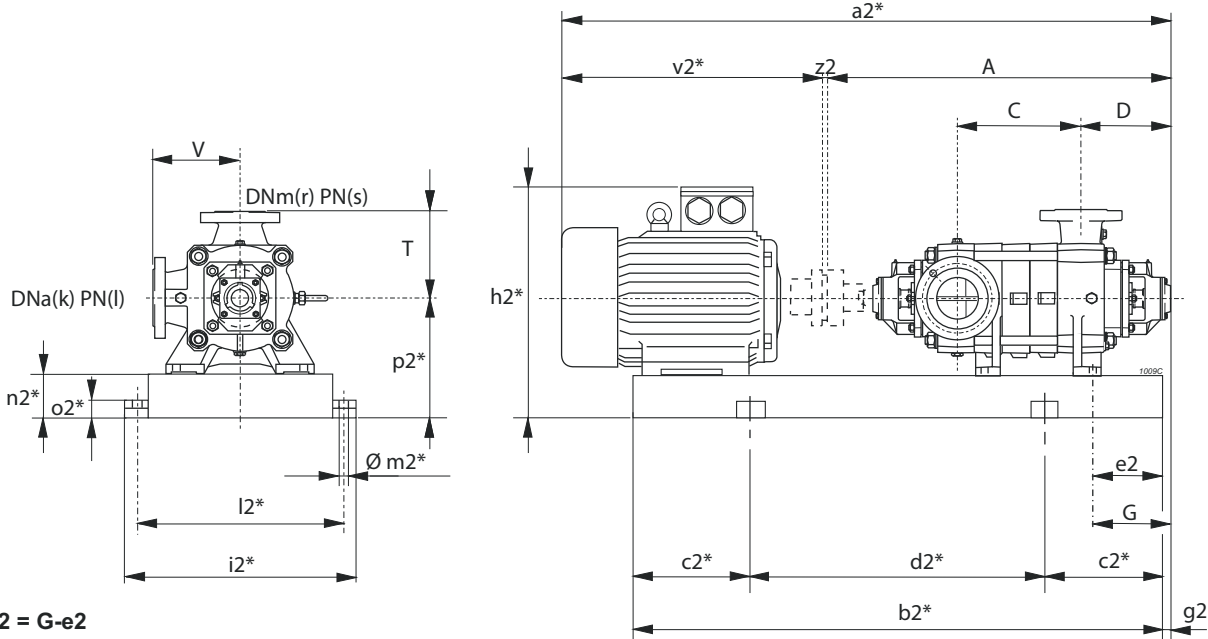

**\* Valori indicativi in funzione della marca di motore utilizzato**  
 Indicatives values according to the type of motor installed

Pump Pompe Pompa	Motor Moteur Motore	BGAM	A	C	D	G	T	V	a2*	b2*	c2*	d2*	e2	h2*	i2*	k	l	l2*	m2*	n2*	o2*	p2*	r	s	v2*	z2	Weight Poids Peso	
																												Series Série Serie
PML(S)	150/2	18,5	180M	829/FP	1190	360	351	301	370	1859	1500	250	1000	60	745	810	200	25	760	22	160	50	475	150	(2)	665	4	992
PML(S)	/2	22	180L	828/FP	1190	360	351	301	370	1899	1538	250	1038	60	745	810	200	25	760	22	160	50	475	150	(2)	705	4	1013
PML(S)	/2	30	200L	856/GP	1190	360	351	301	370	1952	1573	250	1073	60	775	810	200	25	760	22	160	50	475	150	(2)	758	4	1067
PML(S)	/2	37	225S	855/HR	1190	360	351	301	370	1987	1604	250	1104	60	805	810	200	25	760	22	160	50	475	150	(2)	793	4	1150
PML(S)	/2	45	225M	705/HR	1190	360	351	301	370	2012	1629	250	1129	60	805	810	200	25	760	22	160	50	475	150	(2)	818	4	1193
PML(S)	150/3	30	200L	832/GP	1315	485	351	301	370	2077	1698	300	1098	60	775	810	200	25	760	22	160	50	475	150	(2)	758	4	1145
PML(S)	/3	37	225S	831/HR	1315	485	351	301	370	2112	1729	300	1129	60	805	810	200	25	760	22	160	50	475	150	(2)	793	4	1229
PML(S)	/3	45	225M	830/HR	1315	485	351	301	370	2137	1754	300	1154	60	805	810	200	25	760	22	160	50	475	150	(2)	818	4	1272
PML(S)	/3	55	250M	857/IR	1315	485	351	301	370	2199	1796	300	1196	60	850	810	200	25	760	22	160	50	475	150	(2)	880	4	1344
PML(S)	/3	75	280S	708/IR	1315	485	351	301	370	2332	1843	300	1243	60	870	810	200	25	760	22	160	50	475	150	(2)	1013	4	1490
PML(S)	150/4	37	225S	834/HR	1440	610	351	301	370	2237	1854	300	1254	60	805	810	200	25	760	22	160	50	475	150	(2)	793	4	1307
PML(S)	/4	45	225M	833/HR	1440	610	351	301	370	2262	1879	300	1279	60	805	810	200	25	760	22	160	50	475	150	(2)	818	4	1350
PML(S)	/4	55	250M	859/IR	1440	610	351	301	370	2324	1921	300	1321	60	850	810	200	25	760	22	160	50	475	150	(2)	880	4	1423
PML(S)	/4	75	280S	858/IR	1440	610	351	301	370	2457	1968	350	1268	60	870	810	200	25	760	22	160	50	475	150	(2)	1013	4	1569
PML(S)	/4	90	280M	711/LR	1440	610	351	301	370	2508	2019	350	1319	60	870	810	200	25	760	22	160	50	475	150	(2)	1064	4	1638
PML(S)	150/5	45	225M	836/HR	1565	735	351	301	370	2387	2004	350	1304	60	805	810	200	25	760	22	160	50	475	150	(2)	818	4	1429
PML(S)	/5	55	250M	861/IR	1565	735	351	301	370	2449	2046	350	1346	60	850	810	200	25	760	22	160	50	475	150	(2)	880	4	1502
PML(S)	/5	75	280S	835/IR	1565	735	351	301	370	2582	2093	350	1393	60	870	810	200	25	760	22	160	50	475	150	(2)	1013	4	1647
PML(S)	/5	90	280M	860/LR	1565	735	351	301	370	2633	2144	350	1444	60	870	810	200	25	760	22	160	50	475	150	(2)	1064	4	1717
PML(S)	/5	110	315S	714/LS	1565	735	351	301	370	2780	2220	350	1520	60	1030	810	200	25	760	22	160	50	475	150	(2)	1211	4	2007
PML(S)	150/6	55	250M	838/IR	1690	860	351	301	370	2574	2171	350	1471	60	850	810	200	25	760	22	160	50	475	150	(2)	880	4	1580
PML(S)	/6	75	280S	837/IR	1690	860	351	301	370	2707	2218	350	1518	60	870	810	200	25	760	22	160	50	475	150	(2)	1013	4	1726
PML(S)	/6	90	280M	863/LR	1690	860	351	301	370	2758	2269	400	1469	60	870	810	200	25	760	22	160	50	475	150	(2)	1064	4	1795
PML(S)	/6	110	315S	862/LS	1690	860	351	301	370	2905	2345	400	1545	60	1030	810	200	25	760	22	160	50	475	150	(2)	1211	4	2085
PML(S)	/6	132	315M	717/MS	1690	860	351	301	370	3015	2455	400	1655	60	1030	810	200	25	760	22	160	50	475	150	(2)	1321	4	2213
PML(S)	/6	160	315L	717/MS	1690	860	351	301	370	3015	2455	400	1655	60	1030	810	200	25	760	22	160	50	475	150	(2)	1321	4	2308
PML(S)	150/7	75	280S	839/IR	1815	985	351	301	370	2832	2343	400	1543	60	870	810	200	25	760	22	160	50	475	150	(2)	1013	4	1805
PML(S)	/7	90	280M	865/LR	1815	985	351	301	370	2883	2394	400	1594	60	870	810	200	25	760	22	160	50	475	150	(2)	1064	4	1874
PML(S)	/7	110	315S	864/LS	1815	985	351	301	370	3030	2470	400	1670	60	1030	810	200	25	760	22	160	50	475	150	(2)	1211	4	2164
PML(S)	/7	132	315M	720/MS	1815	985	351	301	370	3140	2580	450	1680	60	1030	810	200	25	760	22	160	50	475	150	(2)	1321	4	2292
PML(S)	/7	160	315L	720/MS	1815	985	351	301	370	3140	2580	450	1680	60	1030	810	200	25	760	22	160	50	475	150	(2)	1321	4	2387

BGAM = Base and coupling  
 \* = Indicatives values according to the type of motor installed.  
 ○ Motor in IE4 efficiency class according to EU REGULATION 2019/1781. Available in other efficiency classes for non-EU markets.  
 (2) PML=40 bar PMLS=63 bar

BGAM = Socle et accouplement  
 \* = Valeurs indicatives en fonction de la marque du moteur utilisé.  
 ○ Moteur en classe de rendement IE4 conformément au RÉGLEMENT UE2019/1781. Disponibili in différentes classes de rendement pour les marchés hors UE.  
 (2) PML=40 bar PMLS=63 bar

BGAM = Base giunto e coprigiunto  
 \* = Valori indicativi in funzione della marca di motore utilizzato.  
 ○ Motore in classe di efficienza IE4 in conformità al REGOLAMENTO UE2019/1781. Disponibili in altre classi di efficienza per mercati extra UE.  
 (2) PML=40 bar PMLS=63 bar

Selection - dimensions and weights for base mounted electric pumps  
 Sélection - dimensions et poids des électropompes sur socle  
 Selezione - dimensioni e pesi elettropompe su base

COUPLINGS WITH STANDARDIZED ENCLOSED ELECTRIC MOTORS  
 ACCOUPLEMENTS AVEC MOTEURS ÉLECTRIQUES FERMÉS NORMALISÉS  
 ACCOPIAMENTI CON MOTORI ELETTRICI CHIUSI NORMALIZZATI

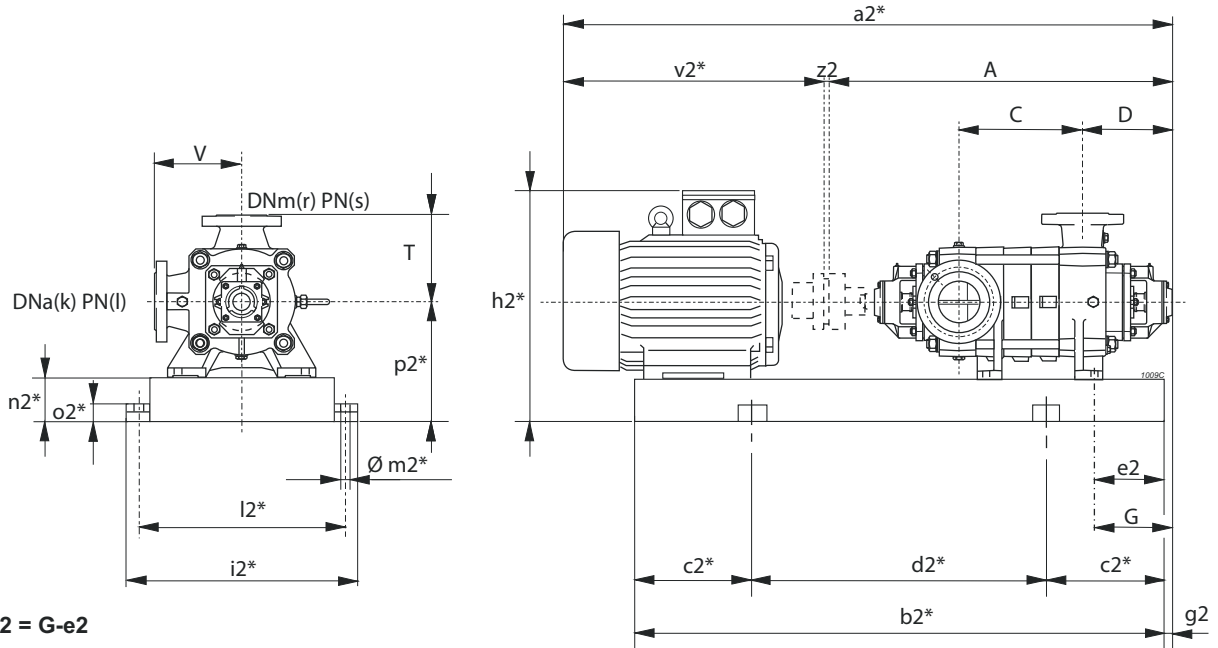

$g2 = G - e2$

\* Valori indicativi in funzione della marca di motore utilizzato  
 Indicatives values according to the type of motor installed

Pump Pompe Pompa		Motor Moteur Motore		BGAM	A	C	D	G	T	V	a2*	b2*	c2*	d2*	e2	h2*	i2*	k	l	l2*	m2*	n2*	o2*	p2*	r	s	v2*	z2	Weight Poids Peso	
Series Série Serie	Type Type Tipo	[kW]	Size Taille Grand.	Type Type Tipo	[mm]																									[kg]
PML(S)	150/8	75	280S	841/IR	1940	1110	351	301	370	370	2957	2468	400	1668	60	870	810	200	25	760	22	160	50	475	150	(2)	1013	4	1883	
PML(S)	/8	90	280M	867/LR	1940	1110	351	301	370	370	3008	2519	400	1719	60	870	810	200	25	760	22	160	50	475	150	(2)	1064	4	1953	
PML(S)	/8	110	315S	866/LS	1940	1110	351	301	370	370	3155	2595	450	1695	60	1030	810	200	25	760	22	160	50	475	150	(2)	1211	4	2243	
PML(S)	/8	132	315M	840/MS	1940	1110	351	301	370	370	3265	2654	450	1754	60	1030	810	200	25	760	22	160	50	475	150	(2)	1321	4	2369	
PML(S)	/8	160	315L	840/MS	1940	1110	351	301	370	370	3265	2654	450	1754	60	1030	810	200	25	760	22	160	50	475	150	(2)	1321	4	2464	
PML(S)	/8	200	315L	723/IE4/NS	1940	1110	351	301	370	370	3355	2795	450	1895	198	1030	810	200	25	760	22	160	50	475	150	(2)	1411	4	2617	
PML(S)	150/9	90	280M	844/LR	2065	1235	351	301	370	370	3133	2644	450	1744	60	870	810	200	25	760	22	160	50	475	150	(2)	1064	4	2031	
PML(S)	/9	110	315S	868/LS	2065	1235	351	301	370	370	3280	2720	450	1820	60	1030	810	200	25	760	22	160	50	475	150	(2)	1211	4	2321	
PML(S)	/9	132	315M	843/MS	2065	1235	351	301	370	370	3390	2779	450	1879	60	1030	810	200	25	760	22	160	50	475	150	(2)	1321	4	2448	
PML(S)	/9	160	315L	843/MS	2065	1235	351	301	370	370	3390	2779	450	1879	60	1030	810	200	25	760	22	160	50	475	150	(2)	1321	4	2543	
PML(S)	/9	200	315L	842/IE4/NS	2065	1235	351	301	370	370	3480	2920	500	1920	198	1030	810	200	25	760	22	160	50	475	150	(2)	1411	4	2696	
PML(S)	150/10	90	280M	848/LR	2190	1360	351	301	370	370	3258	2769	450	1869	60	870	810	200	25	760	22	160	50	475	150	(2)	1064	4	2110	
PML(S)	/10	110	315S	869/LS	2190	1360	351	301	370	370	3405	2845	450	1945	60	1030	810	200	25	760	22	160	50	475	150	(2)	1211	4	2400	
PML(S)	/10	132	315M	847/MS	2190	1360	351	301	370	370	3515	2904	500	1904	60	1030	810	200	25	760	22	160	50	475	150	(2)	1321	4	2526	
PML(S)	/10	160	315L	847/MS	2190	1360	351	301	370	370	3515	2904	500	1904	60	1030	810	200	25	760	22	160	50	475	150	(2)	1321	4	2621	
PML(S)	/10	200	315L	846/IE4/NS	2190	1360	351	301	370	370	3605	3045	500	2045	198	1030	810	200	25	760	22	160	50	475	150	(2)	1411	4	2775	
PML(S)	/10	250	355M	845/NS	2190	1360	351	301	370	370	3750	3089	500	2089	100	1136	880	200	25	830	22	180	50	535	150	(2)	1556	4	3149	

BGAM = Base and coupling  
 \* = Indicatives values according to the type of motor installed.

○ Motor in IE4 efficiency class according to EU REGULATION 2019/1781. Available in other efficiency classes for non-EU markets.

(2) PML=40 bar PMLS=63 bar

BGAM = Socle et accouplement  
 \* = Valeurs indicatives en fonction de la marque du moteur utilisé.

○ Moteur en classe de rendement IE4 conformément au RÈGLEMENT UE2019/1781. Disponibilités en différentes classes de rendement pour les marchés hors UE.

(2) PML=40 bar PMLS=63 bar

BGAM = Base giunto e coprigiunto  
 \* = Valori indicativi in funzione della marca di motore utilizzato.

○ Motore in classe di efficienza IE4 in conformità al REGOLAMENTO UE2019/1781. Disponibili in altre classi di efficienza per mercati extra UE.

(2) PML=40 bar PMLS=63 bar

# PML 150H

2P / 50Hz



Selection - dimensions and weights for base mounted electric pumps  
 Sélection - dimensions et poids des électropompes sur socle  
 Selezione - dimensioni e pesi elettropompe su base

COUPLINGS WITH STANDARDIZED ENCLOSED ELECTRIC MOTORS  
 ACCOUPLEMENTS AVEC MOTEURS ÉLECTRIQUES FERMÉS NORMALISÉS  
 ACCOPIAMENTI CON MOTORI ELETTRICI CHIUSI NORMALIZZATI

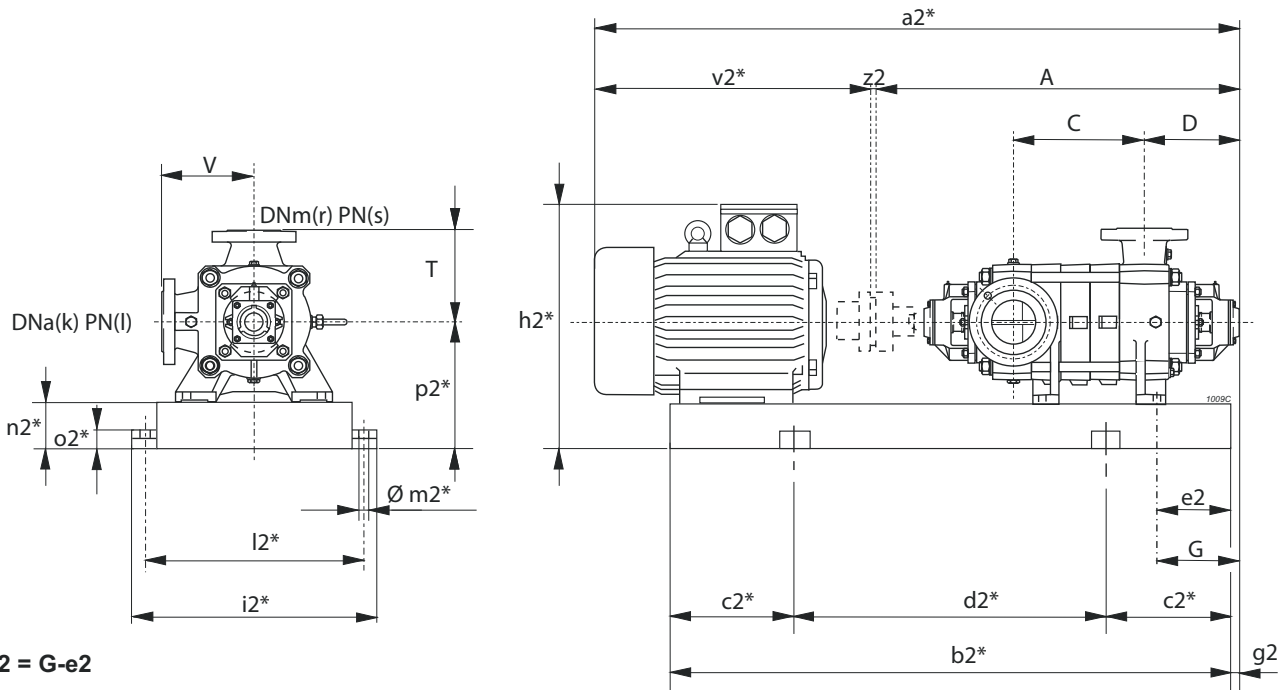

$g2 = G - e2$

\* Valori indicativi in funzione della marca di motore utilizzato  
 Indicatives values according to the type of motor installed

Pump Pompe Pompa	Motor Moteur Motore	BGAM	A	C	D	G	T	V	a2*	b2*	c2*	d2*	e2	h2*	i2*	k	l	l2*	m2*	n2*	o2*	p2*	r	s	v2*	z2	Weight Poids Peso		
Series Série Serie	Type Type Tipo	[kW]	Size Taille Grand.	Type Type Tipo	[mm]																				[kg]				
PML(S)	150H/2	160	315L	825/IS	1190	360	351	301	370	370	2485	1925	300	1325	60	1030	810	200	25	760	22	160	50	475	150	(2)	1291	4	1960
PML(S)	/2	200	315L	824/IE4/LS	1190	360	351	301	370	370	2575	1925	300	1325	60	1030	810	200	25	760	22	160	50	475	150	(2)	1381	4	1965
PML(S)	/2	250	355M	823/LS	1190	360	351	301	370	370	2720	2019	350	1319	100	1136	880	200	25	830	22	180	50	535	150	(2)	1526	4	2472
PML(S)	/2	280	355L	823/LS	1190	360	351	301	370	370	2720	2019	350	1319	100	1136	880	200	25	830	22	180	50	535	150	(2)	1526	4	2597
PML(S)	/2	315	355L	823/MS	1190	360	351	301	370	370	2720	2089	350	1389	100	1136	880	200	25	830	22	180	50	535	150	(2)	1526	4	2601
PML(S)	/2	355	355L	823/MS	1190	360	351	301	370	370	2720	2089	350	1389	100	1136	880	200	25	830	22	180	50	535	150	(2)	1526	4	2591
PML(S)	150H/3	250	355M	826/LS	1315	485	351	301	370	370	2845	2144	350	1444	100	1136	880	200	25	830	22	180	50	535	150	(2)	1526	4	2554
PML(S)	/3	280	355L	826/LS	1315	485	351	301	370	370	2845	2144	350	1444	100	1136	880	200	25	830	22	180	50	535	150	(2)	1526	4	2679
PML(S)	/3	315	355L	826/MS	1315	485	351	301	370	370	2845	2214	350	1514	100	1136	880	200	25	830	22	180	50	535	150	(2)	1526	4	2683
PML(S)	/3	355	355L	826/MS	1315	485	351	301	370	370	2845	2214	350	1514	100	1136	880	200	25	830	22	180	50	535	150	(2)	1526	4	2673
PML(S)	150H/4	315	355L	827/MS	1440	610	351	301	370	370	2970	2339	400	1539	100	1136	880	200	25	830	22	180	50	535	150	(2)	1526	4	2765
PML(S)	/4	355	355L	827/MS	1440	610	351	301	370	370	2970	2339	400	1539	100	1136	880	200	25	830	22	180	50	535	150	(2)	1526	4	2755

BGAM = Base and coupling

\* = Indicatives values according to the type of motor installed.

○ Motor in IE4 efficiency class according to EU REGULATION 2019/1781. Available in other efficiency classes for non-EU markets.

(2) PML=40 bar PMLS=63 bar

BGAM = Socle et accouplement

\* = Valeurs indicatives en fonction de la marque du moteur utilisé.

○ Moteur en classe de rendement IE4 conformément au RÈGLEMENT UE2019/1781. Disponibilité en différentes classes de rendement pour les marchés hors UE.

(2) PML=40 bar PMLS=63 bar

BGAM = Base giunto e coprigiunto

\* = Valori indicativi in funzione della marca di motore utilizzato.

○ Motore in classe di efficienza IE4 in conformità al REGOLAMENTO UE2019/1781. Disponibili in altre classi di efficienza per mercati extra UE.

(2) PML=40 bar PMLS=63 bar

Selection - dimensions and weights for base mounted electric pumps  
 Sélection - dimensions et poids des électropompes sur socle  
 Selezione - dimensioni e pesi elettropompe su base

COUPLINGS WITH STANDARDIZED ENCLOSED ELECTRIC MOTORS  
 ACCOUPLEMENTS AVEC MOTEURS ÉLECTRIQUES FERMÉS NORMALISÉS  
 ACCOPIAMENTI CON MOTORI ELETTRICI CHIUSI NORMALIZZATI

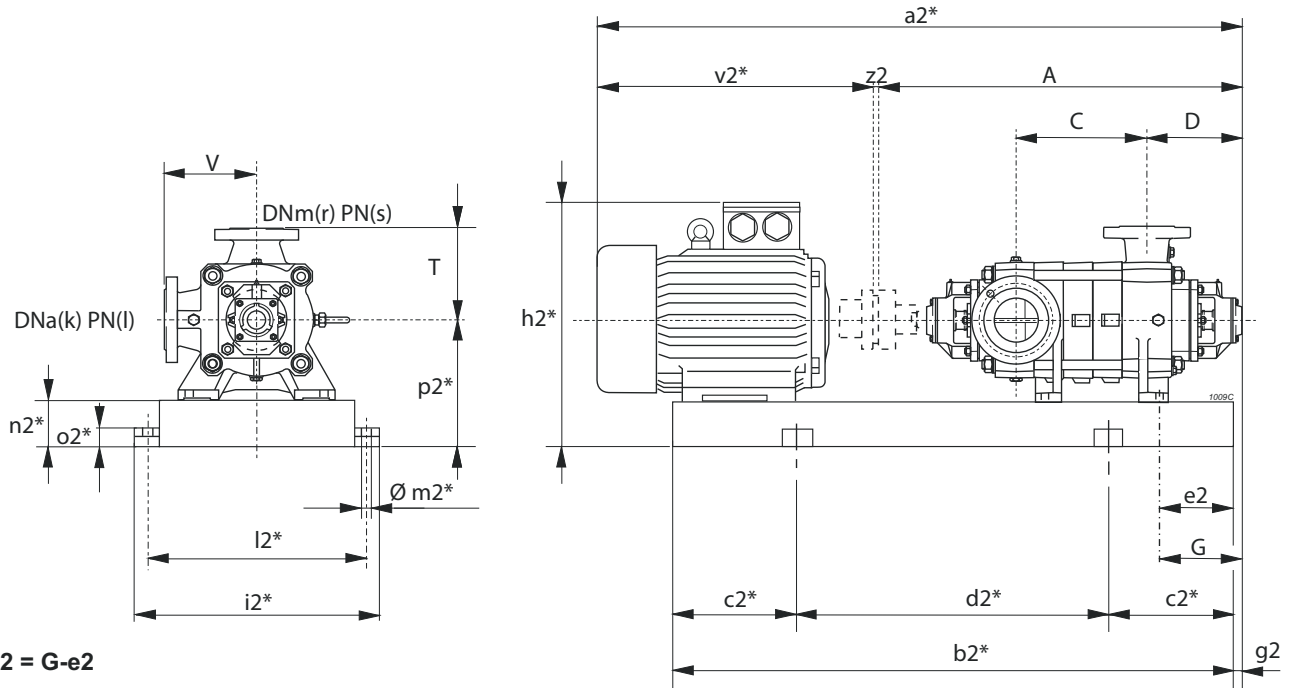

\* Valori indicativi in funzione della marca di motore utilizzato  
 Indicatives values according to the type of motor installed

Pump Pompe Pompa	Motor Moteur Motore	BGAM	A	C	D	G	T	V	a2*	b2*	c2*	d2*	e2	h2*	i2*	k	l	l2*	m2*	n2*	o2*	p2*	r	s	v2*	z2	Weight Poids Peso		
Series Série Serie	Type Type Tipo	[kW]	Size Taille Grand.	Type Type Tipo	[mm]																				[kg]				
PML(S)	150H/2	18,5	180M	829/FP	1190	360	351	301	370	370	1859	1500	250	1000	60	745	810	200	25	760	22	160	50	475	150	(2)	665	4	992
PML(S)	/2	22	180L	828/FP	1190	360	351	301	370	370	1899	1538	250	1038	60	745	810	200	25	760	22	160	50	475	150	(2)	705	4	1013
PML(S)	/2	30	200L	856/GP	1190	360	351	301	370	370	1952	1573	250	1073	60	775	810	200	25	760	22	160	50	475	150	(2)	758	4	1067
PML(S)	/2	37	225S	855/HR	1190	360	351	301	370	370	1987	1604	250	1104	60	805	810	200	25	760	22	160	50	475	150	(2)	793	4	1150
PML(S)	/2	45	225M	705/HR	1190	360	351	301	370	370	2012	1629	250	1129	60	805	810	200	25	760	22	160	50	475	150	(2)	818	4	1193
PML(S)	150H/3	30	200L	832/GP	1315	485	351	301	370	370	2077	1698	300	1098	60	775	810	200	25	760	22	160	50	475	150	(2)	758	4	1145
PML(S)	/3	37	225S	831/HR	1315	485	351	301	370	370	2112	1729	300	1129	60	805	810	200	25	760	22	160	50	475	150	(2)	793	4	1229
PML(S)	/3	45	225M	830/HR	1315	485	351	301	370	370	2137	1754	300	1154	60	805	810	200	25	760	22	160	50	475	150	(2)	818	4	1272
PML(S)	/3	55	250M	857/IR	1315	485	351	301	370	370	2199	1796	300	1196	60	850	810	200	25	760	22	160	50	475	150	(2)	880	4	1344
PML(S)	/3	75	280S	708/IR	1315	485	351	301	370	370	2332	1843	300	1243	60	870	810	200	25	760	22	160	50	475	150	(2)	1013	4	1490
PML(S)	150H/4	37	225S	834/HR	1440	610	351	301	370	370	2237	1854	300	1254	60	805	810	200	25	760	22	160	50	475	150	(2)	793	4	1307
PML(S)	/4	45	225M	833/HR	1440	610	351	301	370	370	2262	1879	300	1279	60	805	810	200	25	760	22	160	50	475	150	(2)	818	4	1350
PML(S)	/4	55	250M	859/IR	1440	610	351	301	370	370	2324	1921	300	1321	60	850	810	200	25	760	22	160	50	475	150	(2)	880	4	1423
PML(S)	/4	75	280S	858/IR	1440	610	351	301	370	370	2457	1968	350	1268	60	870	810	200	25	760	22	160	50	475	150	(2)	1013	4	1569
PML(S)	/4	90	280M	711/LR	1440	610	351	301	370	370	2508	2019	350	1319	60	870	810	200	25	760	22	160	50	475	150	(2)	1064	4	1638

BGAM = Base and coupling  
 \* = Indicatives values according to the type of motor installed.

○ Motor in IE4 efficiency class according to EU REGULATION 2019/1781. Available in other efficiency classes for non-EU markets.

(2) PML=40 bar PMLS=63 bar

BGAM = Socle et accouplement  
 \* = Valeurs indicatives en fonction de la marque du moteur utilisé.  
 ○ Moteur en classe de rendement IE4 conformément au RÈGLEMENT UE2019/1781. Disponibilit  en diff rentes classes de rendement pour les march s hors UE.

(2) PML=40 bar PMLS=63 bar

BGAM = Base giunto e coprigiunto  
 \* = Valori indicativi in funzione della marca di motore utilizzato.  
 ○ Motore in classe di efficienza IE4 in conformit  al REGOLAMENTO UE2019/1781. Disponibili in altre classi di efficienza per mercati extra UE.

(2) PML=40 bar PMLS=63 bar