

Overall dimensions and weights
 Dimensions d'encombrement et poids
 Dimensioni di ingombro e pesi

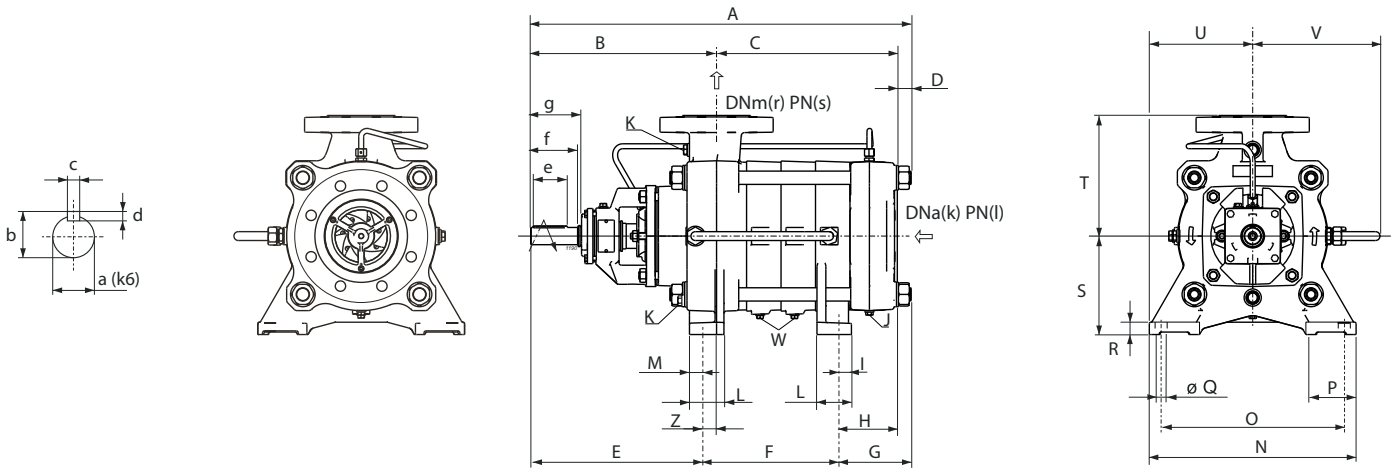

Séries Série Serie	Type Type Tipo	A	B	C	D	E	F	G	H	S	T	U	V	Z	Weight Poids Peso
		[mm]													[kg]
PMA(S)	65/2	554	319	207	28,5	289	135	130	102	180	220	239	220	30	100
PMA(S)	65/3	619	319	272	28,5	289	200	130	102	180	220	239	220	30	114
PMA(S)	65/4	684	319	337	28,5	289	265	130	102	180	220	239	220	30	128
PMA(S)	65/5	749	319	402	28,5	289	330	130	102	180	220	239	220	30	142
PMA(S/H)	65/6	814	319	467	28,5	289	395	130	102	180	220	239	220	30	156
PMA(S/H)	65/7	879	319	532	28,5	289	460	130	102	180	220	239	220	30	170
PMA(S/H)	65/8	944	319	597	28,5	289	525	130	102	180	220	239	220	30	184
PMA(S/H)	65/9	1009	319	662	28,5	289	590	130	102	180	220	239	220	30	198
PMA(S/H)	65/10	1074	319	727	28,5	289	655	130	102	180	220	239	220	30	212
PMA(S/H)	65/11	1139	319	792	28,5	289	720	130	102	180	220	239	220	30	226
PMA(S/H)	65/12	1204	319	857	28,5	289	785	130	102	180	220	239	220	30	240
PMA(S/H)	65/13	1269	319	922	28,5	289	850	130	102	180	220	239	220	30	254
PMA(S/H)	65/14	1334	319	987	28,5	289	915	130	102	180	220	239	220	30	268
PMA(S/H)	65/15	1399	319	1052	28,5	289	980	130	102	180	220	239	220	30	282
PMA(S/H)	65/16	1464	319	1117	28,5	289	1045	130	102	180	220	239	220	30	296

Foot dimensions Dimensions des pieds Dimensioni dei piedi							
I	L	M	N	O	P	Q	R
[mm]							
21	65	20	370	320	90	18	23

Shaft projection Saille d'arbre Sporgenza d'albero						
a	b	c	d	e	f	g
[mm]						
32	35	10	8	60	75	90

Type Type Tipo	Flanges Brides Flange			
	(k) DNa	(l) PN	(r) DNm	(s) PN
	[mm]	[bar]	[mm]	[bar]
PMA	100	25	65	40
PMAS	100	25	65	63
PMAH	100	40	65	100

Plugs Bouchons Tappi		
J	K	W
G 3/8	G 1/2	G 1/4

Selection - dimensions and weights for base mounted electric pumps
 Sélection - dimensions et poids des électropompes sur socle
 Selezione - dimensioni e pesi elettropompe su base

COUPLINGS WITH STANDARDIZED ENCLOSED ELECTRIC MOTORS
 ACCOUPLEMENTS AVEC MOTEURS ÉLECTRIQUES FERMÉS NORMALISÉS
 ACCOPIAMENTI CON MOTORI ELETTRICI CHIUSI NORMALIZZATI

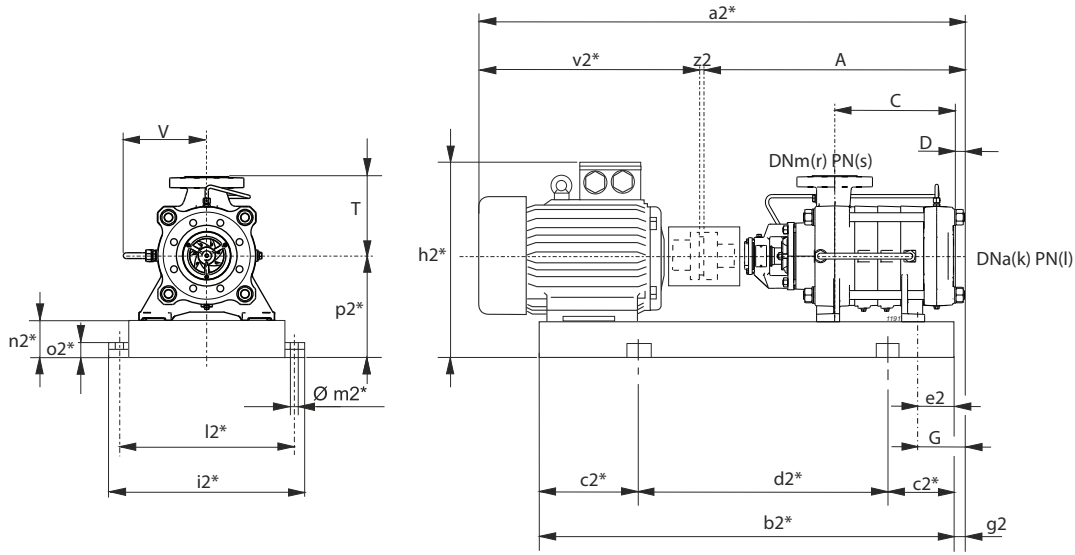

$g2 = G - e2$

* Valori indicativi in funzione della marca di motore utilizzato
 Indicatives values according to the type of motor installed

Pump Pompe Pompa	Motor Moteur Motore	BGAMA	A	C	D	G	T	V	a2*	b2*	c2*	d2*	e2	h2*	i2*	k	l	l2*	m2*	n2*	o2*	p2*	r	s	v2*	z2	Weight Poids Peso		
Series Série Serie	Type Type Tipo	[kW]	Size Taille Grand.	Type Type Tipo	[mm]																				[kg]				
PMA(S)	65/2	11	160M	411/DM	554	206,5	28,5	130	220	220	1185	961	150	661	40	531	500	100	(1)	450	20	100	42	280	65	(2)	627	4	264
PMA(S)	/2	15	160M	411/DM	554	206,5	28,5	130	220	220	1185	961	150	661	40	531	500	100	(1)	450	20	100	42	280	65	(2)	627	4	275
PMA(S)	/2	18,5	160L	412/DM	554	206,5	28,5	130	220	220	1185	1005	150	705	40	531	500	100	(1)	450	20	100	42	280	65	(2)	627	4	288
PMA(S)	/2	22	180M	413/EM	554	206,5	28,5	130	220	220	1223	1015	150	715	40	550	500	100	(1)	450	20	100	42	280	65	(2)	665	4	328
PMA(S)	65/3	15	160M	414/DM	619	271,5	28,5	130	220	220	1250	1026	150	726	40	531	500	100	(1)	450	20	100	42	280	65	(2)	627	4	291
PMA(S)	/3	18,5	160L	415/DM	619	271,5	28,5	130	220	220	1250	1070	200	670	40	531	500	100	(1)	450	20	100	42	280	65	(2)	627	4	304
PMA(S)	/3	22	180M	416/EM	619	271,5	28,5	130	220	220	1288	1080	200	680	40	550	500	100	(1)	450	20	100	42	280	65	(2)	665	4	343
PMA(S)	/3	30	200L	417/FM	619	271,5	28,5	130	220	220	1361	1173	200	773	60	600	540	100	(1)	490	20	100	42	300	65	(2)	738	4	403
PMA(S)	/3	37	200L	417/FM	619	271,5	28,5	130	220	220	1361	1173	200	773	60	600	540	100	(1)	490	20	100	42	300	65	(2)	738	4	431
PMA(S)	65/4	18,5	160L	418/DM	684	336,5	28,5	130	220	220	1315	1135	200	735	40	531	500	100	(1)	450	20	100	42	280	65	(2)	627	4	319
PMA(S)	/4	22	180M	419/EM	684	336,5	28,5	130	220	220	1353	1145	200	745	40	550	500	100	(1)	450	20	100	42	280	65	(2)	665	4	358
PMA(S)	/4	30	200L	420/FM	684	336,5	28,5	130	220	220	1426	1238	200	838	60	600	540	100	(1)	490	20	100	42	300	65	(2)	738	4	418
PMA(S)	/4	37	200L	420/FM	684	336,5	28,5	130	220	220	1426	1238	200	838	60	600	540	100	(1)	490	20	100	42	300	65	(2)	738	4	446
PMA(S)	/4	45	225M	421/FM	684	336,5	28,5	130	220	220	1463	1274	200	874	70	675	585	100	(1)	535	20	120	42	345	65	(2)	775	4	521
PMA(S)	65/5	22	180M	422/EM	749	401,5	28,5	130	220	220	1418	1210	200	810	40	550	500	100	(1)	450	20	100	42	280	65	(2)	665	4	374
PMA(S)	/5	30	200L	423/FM	749	401,5	28,5	130	220	220	1491	1303	200	903	60	600	540	100	(1)	490	20	100	42	300	65	(2)	738	4	434
PMA(S)	/5	37	200L	423/FM	749	401,5	28,5	130	220	220	1491	1303	200	903	60	600	540	100	(1)	490	20	100	42	300	65	(2)	738	4	462
PMA(S)	/5	45	225M	424/FM	749	401,5	28,5	130	220	220	1528	1339	200	939	70	675	585	100	(1)	535	20	120	42	345	65	(2)	775	4	537
PMA(S)	/5	55	250M	425/GM	749	401,5	28,5	130	220	220	1623	1421	250	921	80	745	635	100	(1)	585	20	120	42	370	65	(2)	870	4	646
PMA(S/H)	65/6	30	200L	426/FM	814	466,5	28,5	130	220	220	1556	1368	250	868	60	600	540	100	(1)	490	20	100	42	300	65	(2)	738	4	449
PMA(S/H)	/6	37	200L	426/FM	814	466,5	28,5	130	220	220	1556	1368	250	868	60	600	540	100	(1)	490	20	100	42	300	65	(2)	738	4	477
PMA(S/H)	/6	45	225M	427/FM	814	466,5	28,5	130	220	220	1593	1404	250	904	70	675	585	100	(1)	535	20	120	42	345	65	(2)	775	4	553
PMA(S/H)	/6	55	250M	428/GM	814	466,5	28,5	130	220	220	1688	1486	250	986	80	745	635	100	(1)	585	20	120	42	370	65	(2)	870	4	662
PMA(S/H)	/6	75	280S	429/HM	814	466,5	28,5	130	220	220	1818	1543	250	1043	90	815	695	100	(1)	645	20	140	42	420	65	(2)	1000	4	890
PMA(S/H)	65/7	30	200L	430/FM	879	531,5	28,5	130	220	220	1621	1433	250	933	60	600	540	100	(1)	490	20	100	42	300	65	(2)	738	4	464
PMA(S/H)	/7	37	200L	430/FM	879	531,5	28,5	130	220	220	1621	1433	250	933	60	600	540	100	(1)	490	20	100	42	300	65	(2)	738	4	492
PMA(S/H)	/7	45	225M	431/FM	879	531,5	28,5	130	220	220	1658	1469	250	969	70	675	585	100	(1)	535	20	120	42	345	65	(2)	775	4	568
PMA(S/H)	/7	55	250M	432/GM	879	531,5	28,5	130	220	220	1753	1551	250	1051	80	745	635	100	(1)	585	20	120	42	370	65	(2)	870	4	678
PMA(S/H)	/7	75	280S	433/HM	879	531,5	28,5	130	220	220	1883	1608	250	1108	90	815	695	100	(1)	645	20	140	42	420	65	(2)	1000	4	906
PMA(S/H)	/7	90	280M	434/HM	879	531,5	28,5	130	220	220	1934	1659	300	1059	90	815	695	100	(1)	645	20	140	42	420	65	(2)	1051	4	981
PMA(S/H)	65/8	37	200L	435/FM	944	596,5	28,5	130	220	220	1686	1498	250	998	60	600	540	100	(1)	490	20	100	42	300	65	(2)	738	4	508
PMA(S/H)	/8	45	225M	436/FM	944	596,5	28,5	130	220	220	1723	1534	250	1034	70	675	585	100	(1)	535	20	120	42	345	65	(2)	775	4	584
PMA(S/H)	/8	55	250M	437/GM	944	596,5	28,5	130	220	220	1818	1616	250	1116	80	745	635	100	(1)	585	20	120	42	370	65	(2)	870	4	694

BGAMA = Base and coupling

* = Indicatives values according to the type of motor installed

○ Motor in IE4 efficiency class according to EU REGULATION 2019/1781. Available in other efficiency classes for non-EU markets.

- (1) PMA=25 bar PMAS=25 bar PMAH=40 bar
- (2) PMA=40 bar PMAS=63 bar PMAH=100 bar

BGAMA = Socle et accouplement

* = Valeurs indicatives en fonction de la marque du moteur utilisé

○ Moteur en classe de rendement IE4 conformément au RÈGLEMENT UE2019/1781. Disponible en différentes classes de rendement pour les marchés hors UE.

- (1) PMA=25 bar PMAS=25 bar PMAH=40 bar
- (2) PMA=40 bar PMAS=63 bar PMAH=100 bar

BGAMA = Base giunto e coprigiunto

* = Valori indicativi in funzione della marca di motore utilizzato.

○ Motore in classe di efficienza IE4 in conformità al REGOLAMENTO UE2019/1781. Disponibili in altre classi di efficienza per mercati extra UE.

- (1) PMA=25 bar PMAS=25 bar PMAH=40 bar
- (2) PMA=40 bar PMAS=63 bar PMAH=100 bar

Selection - dimensions and weights for base mounted electric pumps
 Sélection - dimensions et poids des électropompes sur socle
 Selezione - dimensioni e pesi elettropompe su base

COUPLINGS WITH STANDARDIZED ENCLOSED ELECTRIC MOTORS
 ACCOUPLEMENTS AVEC MOTEURS ÉLECTRIQUES FERMÉS NORMALISÉS
 ACCOPIAMENTI CON MOTORI ELETTRICI CHIUSI NORMALIZZATI

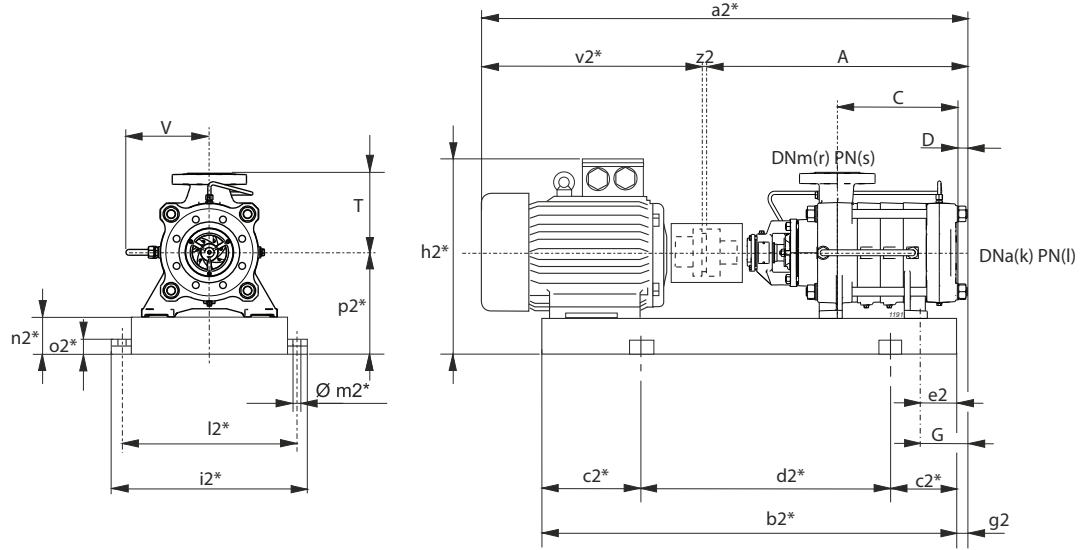

g2 = G-e2

* Valori indicativi in funzione della marca di motore utilizzato
 Indicatives values according to the type of motor installed

Pump Pompe Pompa	Motor Moteur Motore	BGAMA	A	C	D	G	T	V	a2*	b2*	c2*	d2*	e2	h2*	i2*	k	l	l2*	m2*	n2*	o2*	p2*	r	s	v2*	z2	Weight Poids Peso		
Series Série Serie	Type Type Tipo	[kW]	Size Taille Grand.	Type Type Tipo	[mm]																				[kg]				
PMA(S/H)	/8	75	280S	438/HM	944	596,5	28,5	130	220	220	1948	1673	300	1073	90	815	695	100	(1)	645	20	140	42	420	65	(2)	1000	4	922
PMA(S/H)	/8	90	280M	439/HM	944	596,5	28,5	130	220	220	1999	1724	300	1124	90	815	695	100	(1)	645	20	140	42	420	65	(2)	1051	4	997
PMA(S/H)	65/9	45	225M	440/FM	1009	661,5	28,5	130	220	220	1788	1599	250	1099	70	675	585	100	(1)	535	20	120	42	345	65	(2)	775	4	600
PMA(S/H)	/9	55	250M	441/GM	1009	661,5	28,5	130	220	220	1883	1681	300	1081	80	745	635	100	(1)	585	20	120	42	370	65	(2)	870	4	709
PMA(S/H)	/9	75	280S	442/HM	1009	661,5	28,5	130	220	220	2013	1738	300	1138	90	815	695	100	(1)	645	20	140	42	420	65	(2)	1000	4	938
PMA(S/H)	/9	90	280M	443/HM	1009	661,5	28,5	130	220	220	2064	1789	300	1189	90	815	695	100	(1)	645	20	140	42	420	65	(2)	1051	4	1013
PMA(S/H)	/9	110	315S	444/IM	1009	661,5	28,5	130	220	220	2194	1845	300	1245	100	1030	780	100	(1)	730	22	160	50	475	65	(2)	1181	4	1338
PMA(S/H)	65/10	45	225M	445/FM	1074	726,5	28,5	130	220	220	1853	1664	300	1064	70	675	585	100	(1)	535	20	120	42	345	65	(2)	775	4	616
PMA(S/H)	/10	55	250M	446/GM	1074	726,5	28,5	130	220	220	1948	1746	300	1146	80	745	635	100	(1)	585	20	120	42	370	65	(2)	870	4	725
PMA(S/H)	/10	75	280S	447/HM	1074	726,5	28,5	130	220	220	2078	1803	300	1203	90	815	695	100	(1)	645	20	140	42	420	65	(2)	1000	4	954
PMA(S/H)	/10	90	280M	448/HM	1074	726,5	28,5	130	220	220	2129	1854	300	1254	90	815	695	100	(1)	645	20	140	42	420	65	(2)	1051	4	1029
PMA(S/H)	/10	110	315S	449/IM	1074	726,5	28,5	130	220	220	2259	1910	300	1310	100	1030	780	100	(1)	730	22	160	50	475	65	(2)	1181	4	1355
PMA(S/H)	65/11	55	250M	450/GM	1139	791,5	28,5	130	220	220	2013	1811	300	1211	80	745	635	100	(1)	585	20	120	42	370	65	(2)	870	4	741
PMA(S/H)	/11	75	280S	451/HM	1139	791,5	28,5	130	220	220	2143	1868	300	1268	90	815	695	100	(1)	645	20	140	42	420	65	(2)	1000	4	970
PMA(S/H)	/11	90	280M	452/HM	1139	791,5	28,5	130	220	220	2194	1919	300	1319	90	815	695	100	(1)	645	20	140	42	420	65	(2)	1051	4	1045
PMA(S/H)	/11	110	315S	453/IM	1139	791,5	28,5	130	220	220	2324	1975	350	1275	100	1030	780	100	(1)	730	22	160	50	475	65	(2)	1181	4	1371
PMA(S/H)	/11	132	315M	454/IM	1139	791,5	28,5	130	220	220	2434	2034	350	1334	100	1030	780	100	(1)	730	22	160	50	475	65	(2)	1291	4	1445
PMA(S/H)	65/12	55	250M	455/GM	1204	856,5	28,5	130	220	220	2078	1876	300	1276	80	745	635	100	(1)	585	20	120	42	370	65	(2)	870	4	757
PMA(S/H)	/12	75	280S	456/HM	1204	856,5	28,5	130	220	220	2208	1933	300	1333	90	815	695	100	(1)	645	20	140	42	420	65	(2)	1000	4	987
PMA(S/H)	/12	90	280M	457/HM	1204	856,5	28,5	130	220	220	2259	1984	350	1284	90	815	695	100	(1)	645	20	140	42	420	65	(2)	1051	4	1061
PMA(S/H)	/12	110	315S	458/IM	1204	856,5	28,5	130	220	220	2389	2040	350	1340	100	1030	780	100	(1)	730	22	160	50	475	65	(2)	1181	4	1388
PMA(S/H)	/12	132	315M	459/IM	1204	856,5	28,5	130	220	220	2499	2099	350	1399	100	1030	780	100	(1)	730	22	160	50	475	65	(2)	1291	4	1462
PMA(S/H)	65/13	75	280S	460/HM	1269	921,5	28,5	130	220	220	2273	1998	350	1298	90	815	695	100	(1)	645	20	140	42	420	65	(2)	1000	4	1003
PMA(S/H)	/13	90	280M	461/HM	1269	921,5	28,5	130	220	220	2324	2049	350	1349	90	815	695	100	(1)	645	20	140	42	420	65	(2)	1051	4	1077
PMA(S/H)	/13	110	315S	462/IM	1269	921,5	28,5	130	220	220	2454	2105	350	1405	100	1030	780	100	(1)	730	22	160	50	475	65	(2)	1181	4	1404
PMA(S/H)	/13	132	315M	463/IM	1269	921,5	28,5	130	220	220	2564	2215	350	1515	100	1030	780	100	(1)	730	22	160	50	475	65	(2)	1291	4	1480
PMA(S/H)	/13	160	315L	463/IM	1269	921,5	28,5	130	220	220	2564	2215	350	1515	100	1030	780	100	(1)	730	22	160	50	475	65	(2)	1291	4	1558
PMA(S/H)	65/14	75	280S	464/HM	1334	986,5	28,5	130	220	220	2338	2063	350	1363	90	815	695	100	(1)	645	20	140	42	420	65	(2)	1000	4	1019
PMA(S/H)	/14	90	280M	465/HM	1334	986,5	28,5	130	220	220	2389	2114	350	1414	90	815	695	100	(1)	645	20	140	42	420	65	(2)	1051	4	1093
PMA(S/H)	/14	110	315S	466/IM	1334	986,5	28,5	130	220	220	2519	2170	350	1470	100	1030	780	100	(1)	730	22	160	50	475	65	(2)	1181	4	1421
PMA(S/H)	/14	132	315M	467/IM	1334	986,5	28,5	130	220	220	2629	2280	400	1480	100	1030	780	100	(1)	730	22	160	50	475	65	(2)	1291	4	1497
PMA(S/H)	/14	160	315L	467/IM	1334	986,5	28,5	130	220	220	2629	2280	400	1480	100	1030	780	100	(1)	730	22	160	50	475	65	(2)	1291	4	1575
PMA(S/H)	65/15	90	280M	500/HM	1399	1051,5	28,5	130	220	220	2454	2179	350	1479	90	815	695	100	(1)	645	20	140	42	420	65	(2)	1051	4	1109

BGAMA = Base and coupling

* = Indicatives values according to the type of motor installed

○ Motor in IE4 efficiency class according to EU REGULATION 2019/1781. Available in other efficiency classes for non-EU markets.

(1) PMA=25 bar PMAS=25 bar PMAH=40 bar

(2) PMA=40 bar PMAS=63 bar PMAH=100 bar

BGAMA = Socle et accouplement

* = Valeurs indicatives en fonction de la marque du moteur utilisé

○ Moteur en classe de rendement IE4 conformément au RÈGLEMENT UE2019/1781. Disponibilités en différentes classes de rendement pour les marchés hors UE.

(1) PMA=25 bar PMAS=25 bar PMAH=40 bar

(2) PMA=40 bar PMAS=63 bar PMAH=100 bar

BGAMA = Base giunto e coprigiunto

* = Valori indicativi in funzione della marca di motore utilizzato.

○ Motore in classe di efficienza IE4 in conformità al REGOLAMENTO UE2019/1781. Disponibili in altre classi di efficienza per mercati extra UE.

(1) PMA=25 bar PMAS=25 bar PMAH=40 bar

(2) PMA=40 bar PMAS=63 bar PMAH=100 bar

Selection - dimensions and weights for base mounted electric pumps
Sélection - dimensions et poids des électropompes sur socle
 Selezione - dimensioni e pesi elettropompe su base

COUPLINGS WITH STANDARDIZED ENCLOSED ELECTRIC MOTORS
 ACCOUPLEMENTS AVEC MOTEURS ÉLECTRIQUES FERMÉS NORMALISÉS
 ACCOPPIAMENTI CON MOTORI ELETTRICI CHIUSI NORMALIZZATI

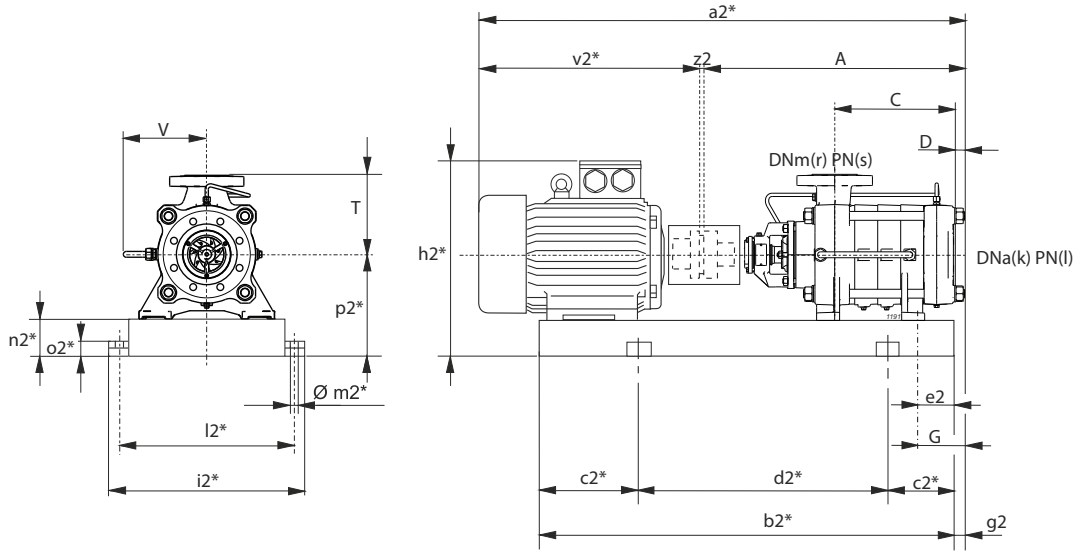

$g2 = G - e2$

* Valori indicativi in funzione della marca di motore utilizzato
Indicatives values according to the type of motor installed

Pump Pompe Pompa	Motor Moteur Motore	BGAMA	A	C	D	G	T	V	a2*	b2*	c2*	d2*	e2	h2*	i2*	k	l	l2*	m2*	n2*	o2*	p2*	r	s	v2*	z2	Weight Poids Peso		
Series Série Serie	Type Type Tipo	[kW]	Size Taille Grand.	Type Type Tipo	[mm]																				[kg]				
PMA(S/H)	/15	110	315S	501/IM	1399	1051,5	28,5	130	220	220	2584	2235	350	1535	100	1030	780	100	(1)	730	22	160	50	475	65	(2)	1181	4	1437
PMA(S/H)	/15	132	315M	502/IM	1399	1051,5	28,5	130	220	220	2694	2294	400	1494	100	1030	780	100	(1)	730	22	160	50	475	65	(2)	1291	4	1511
PMA(S/H)	/15	160	315L	503/IM	1399	1051,5	28,5	130	220	220	2694	2345	400	1545	100	1030	780	100	(1)	730	22	160	50	475	65	(2)	1291	4	1591
PMA(S/H)	/15	200	315L	504/IE4/LQ	1399	1051,5	28,5	130	220	220	2784	2438	400	1638	198	1030	780	100	(1)	730	22	160	50	475	65	(2)	1381	4	1735
PMA(S/H)	65/16	90	280M	511/HM	1464	1116,5	28,5	130	220	220	2519	2244	350	1544	90	815	695	100	(1)	645	20	140	42	420	65	(2)	1051	4	1125
PMA(S/H)	/16	110	315S	512/IM	1464	1116,5	28,5	130	220	220	2649	2300	400	1500	100	1030	780	100	(1)	730	22	160	50	475	65	(2)	1181	4	1453
PMA(S/H)	/16	132	315M	513/IM	1464	1116,5	28,5	130	220	220	2759	2359	400	1559	100	1030	780	100	(1)	730	22	160	50	475	65	(2)	1291	4	1528
PMA(S/H)	/16	160	315L	514/IM	1464	1116,5	28,5	130	220	220	2759	2410	400	1610	100	1030	780	100	(1)	730	22	160	50	475	65	(2)	1291	4	1608
PMA(S/H)	/16	200	315L	515/IE4/LQ	1464	1116,5	28,5	130	220	220	2849	2503	400	1703	198	1030	780	100	(1)	730	22	160	50	475	65	(2)	1381	4	1752

BGAMA = Base and coupling

* = Indicatives values according to the type of motor installed

○ Motor in IE4 efficiency class according to EU REGULATION 2019/1781. Available in other efficiency classes for non-EU markets.

(1) PMA=25 bar PMAS=25 bar PMAH=40 bar

(2) PMA=40 bar PMAS=63 bar PMAH=100 bar

BGAMA = Socle et accouplement

* = Valeurs indicatives en fonction de la marque du moteur utilisé

○ Moteur en classe de rendement IE4 conformément au RÈGLEMENT UE2019/1781. Disponibilité en différentes classes de rendement pour les marchés hors UE.

(1) PMA=25 bar PMAS=25 bar PMAH=40 bar

(2) PMA=40 bar PMAS=63 bar PMAH=100 bar

BGAMA = Base giunto e coprigiunto

* = Valori indicativi in funzione della marca di motore utilizzato.

○ Motore in classe di efficienza IE4 in conformità al REGOLAMENTO UE2019/1781. Disponibili in altre classi di efficienza per mercati extra UE.

(1) PMA=25 bar PMAS=25 bar PMAH=40 bar

(2) PMA=40 bar PMAS=63 bar PMAH=100 bar

Selection - dimensions and weights for base mounted electric pumps
 Sélection - dimensions et poids des électropompes sur socle
 Selezione - dimensioni e pesi elettropompe su base

COUPLINGS WITH STANDARDIZED ENCLOSED ELECTRIC MOTORS
 ACCOUPLEMENTS AVEC MOTEURS ÉLECTRIQUES FERMÉS NORMALISÉS
 ACCOPIAMENTI CON MOTORI ELETTRICI CHIUSI NORMALIZZATI

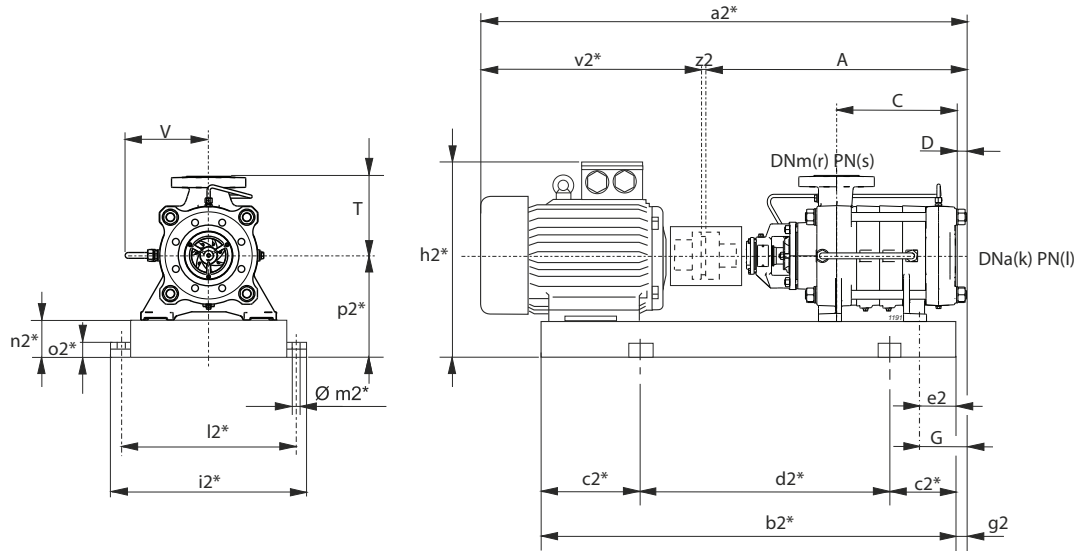

g2 = G-e2

* Valori indicativi in funzione della marca di motore utilizzato
 Indicatives values according to the type of motor installed

Pump Pompe Pompa	Motor Moteur Motore	BGAMA	A	C	D	G	T	V	a2*	b2*	c2*	d2*	e2	h2*	i2*	k	l	l2*	m2*	n2*	o2*	p2*	r	s	v2*	z2	Weight Poids Peso		
Series Série Serie	Type Type Tipo	[kW]	Size Taille Grand.	Type Type Tipo	[mm]																				[kg]				
PMA(S)	65/2	1,1	90S	197/CL	554	206,5	28,5	130	220	220	913	709	100	509	40	418	500	100	(1)	450	20	100	42	280	65	(2)	355	4	152
PMA(S)	/2	1,5	90L	198/CL	554	206,5	28,5	130	220	220	943	734	100	534	40	418	500	100	(1)	450	20	100	42	280	65	(2)	385	4	157
PMA(S)	/2	2,2	100L	199/CL	554	206,5	28,5	130	220	220	963	769	150	469	40	430	500	100	(1)	450	20	100	42	280	65	(2)	405	4	170
PMA(S)	/2	3	100L	199/CL	554	206,5	28,5	130	220	220	963	769	150	469	40	430	500	100	(1)	450	20	100	42	280	65	(2)	405	4	174
PMA(S)	65/3	2,2	100L	201/CL	619	271,5	28,5	130	220	220	1028	834	150	534	40	430	500	100	(1)	450	20	100	42	280	65	(2)	405	4	185
PMA(S)	/3	3	100L	201/CL	619	271,5	28,5	130	220	220	1028	834	150	534	40	430	500	100	(1)	450	20	100	42	280	65	(2)	405	4	189
PMA(S)	/3	4	112M	202/CL	619	271,5	28,5	130	220	220	1063	841	150	541	40	452	500	100	(1)	450	20	100	42	280	65	(2)	440	4	190
PMA(S)	/3	5,5	132S	203/DL	619	271,5	28,5	130	220	220	1078	902	150	602	40	472	500	100	(1)	450	20	100	42	280	65	(2)	455	4	199
PMA(S)	65/4	2,2	100L	204/CL	684	336,5	28,5	130	220	220	1093	899	150	599	40	430	500	100	(1)	450	20	100	42	280	65	(2)	405	4	200
PMA(S)	/4	3	100L	204/CL	684	336,5	28,5	130	220	220	1093	899	150	599	40	430	500	100	(1)	450	20	100	42	280	65	(2)	405	4	204
PMA(S)	/4	4	112M	205/CL	684	336,5	28,5	130	220	220	1128	906	150	606	40	452	500	100	(1)	450	20	100	42	280	65	(2)	440	4	206
PMA(S)	/4	5,5	132S	206/DL	684	336,5	28,5	130	220	220	1143	967	150	667	40	472	500	100	(1)	450	20	100	42	280	65	(2)	455	4	215
PMA(S)	/4	7,5	132M	207/DL	684	336,5	28,5	130	220	220	1178	1005	150	705	40	472	500	100	(1)	450	20	100	42	280	65	(2)	490	4	223
PMA(S)	65/5	3	100L	222/CL	749	401,5	28,5	130	220	220	1158	964	150	664	40	430	500	100	(1)	450	20	100	42	280	65	(2)	405	4	220
PMA(S)	/5	4	112M	223/CL	749	401,5	28,5	130	220	220	1193	971	150	671	40	452	500	100	(1)	450	20	100	42	280	65	(2)	440	4	221
PMA(S)	/5	5,5	132S	224/DL	749	401,5	28,5	130	220	220	1208	1032	150	732	40	472	500	100	(1)	450	20	100	42	280	65	(2)	455	4	230
PMA(S)	/5	7,5	132M	225/DL	749	401,5	28,5	130	220	220	1243	1070	200	670	40	472	500	100	(1)	450	20	100	42	280	65	(2)	490	4	239
PMA(S/H)	65/6	4	112M	226/CL	814	466,5	28,5	130	220	220	1258	1036	150	736	40	452	500	100	(1)	450	20	100	42	280	65	(2)	440	4	237
PMA(S/H)	/6	5,5	132S	227/DL	814	466,5	28,5	130	220	220	1273	1097	200	697	40	472	500	100	(1)	450	20	100	42	280	65	(2)	455	4	245
PMA(S/H)	/6	7,5	132M	228/DL	814	466,5	28,5	130	220	220	1308	1135	200	735	40	472	500	100	(1)	450	20	100	42	280	65	(2)	490	4	254
PMA(S/H)	/6	11	160M	953/EM	814	466,5	28,5	130	220	220	1445	1221	200	821	40	531	500	100	(1)	450	20	100	42	280	65	(2)	627	4	339
PMA(S/H)	65/7	4	112M	229/CL	879	531,5	28,5	130	220	220	1323	1101	200	701	40	452	500	100	(1)	450	20	100	42	280	65	(2)	440	4	252
PMA(S/H)	/7	5,5	132S	230/DL	879	531,5	28,5	130	220	220	1338	1162	200	762	40	472	500	100	(1)	450	20	100	42	280	65	(2)	455	4	261
PMA(S/H)	/7	7,5	132M	231/DL	879	531,5	28,5	130	220	220	1373	1200	200	800	40	472	500	100	(1)	450	20	100	42	280	65	(2)	490	4	270
PMA(S/H)	/7	11	160M	232/EM	879	531,5	28,5	130	220	220	1510	1286	200	886	40	531	500	100	(1)	450	20	100	42	280	65	(2)	627	4	354
PMA(S/H)	65/8	5,5	132S	233/DL	944	596,5	28,5	130	220	220	1403	1227	200	827	40	472	500	100	(1)	450	20	100	42	280	65	(2)	455	4	276
PMA(S/H)	/8	7,5	132M	234/DL	944	596,5	28,5	130	220	220	1438	1265	200	865	40	472	500	100	(1)	450	20	100	42	280	65	(2)	490	4	285
PMA(S/H)	/8	11	160M	235/EM	944	596,5	28,5	130	220	220	1575	1351	250	851	40	531	500	100	(1)	450	20	100	42	280	65	(2)	627	4	370
PMA(S/H)	/8	15	160L	236/EM	944	596,5	28,5	130	220	220	1575	1395	250	895	40	531	500	100	(1)	450	20	100	42	280	65	(2)	627	4	382
PMA(S/H)	65/9	5,5	132S	237/DL	1009	661,5	28,5	130	220	220	1468	1292	200	892	40	472	500	100	(1)	450	20	100	42	280	65	(2)	455	4	291
PMA(S/H)	/9	7,5	132M	238/DL	1009	661,5	28,5	130	220	220	1503	1330	200	930	40	472	500	100	(1)	450	20	100	42	280	65	(2)	490	4	300
PMA(S/H)	/9	11	160M	239/EM	1009	661,5	28,5	130	220	220	1640	1416	250	916	40	531	500	100	(1)	450	20	100	42	280	65	(2)	627	4	385
PMA(S/H)	/9	15	160L	240/EM	1009	661,5	28,5	130	220	220	1640	1460	250	960	40	531	500	100	(1)	450	20	100	42	280	65	(2)	627	4	398
PMA(S/H)	65/10	5,5	132S	241/DL	1074	726,5	28,5	130	220	220	1533	1357	250	857	40	472	500	100	(1)	450	20	100	42	280	65	(2)	455	4	307

BGAMA = Base and coupling

* = Indicatives values according to the type of motor installed

- (1) PMA=25 bar PMAS=25 bar PMAH=40 bar
 (2) PMA=40 bar PMAS=63 bar PMAH=100 bar

BGAMA = Socle et accouplement

* = Valeurs indicatives en fonction de la marque du moteur utilisé

- (1) PMA=25 bar PMAS=25 bar PMAH=40 bar
 (2) PMA=40 bar PMAS=63 bar PMAH=100 bar

BGAMA = Base giunto e coprigiunto

* = Valori indicativi in funzione della marca di motore utilizzato.

- (1) PMA=25 bar PMAS=25 bar PMAH=40 bar
 (2) PMA=40 bar PMAS=63 bar PMAH=100 bar

Selection - dimensions and weights for base mounted electric pumps
Sélection - dimensions et poids des électropompes sur socle
 Selezione - dimensioni e pesi elettropompe su base

COUPLINGS WITH STANDARDIZED ENCLOSED ELECTRIC MOTORS
 ACCOUPLEMENTS AVEC MOTEURS ÉLECTRIQUES FERMÉS NORMALISÉS
 ACCOPPIAMENTI CON MOTORI ELETTRICI CHIUSI NORMALIZZATI

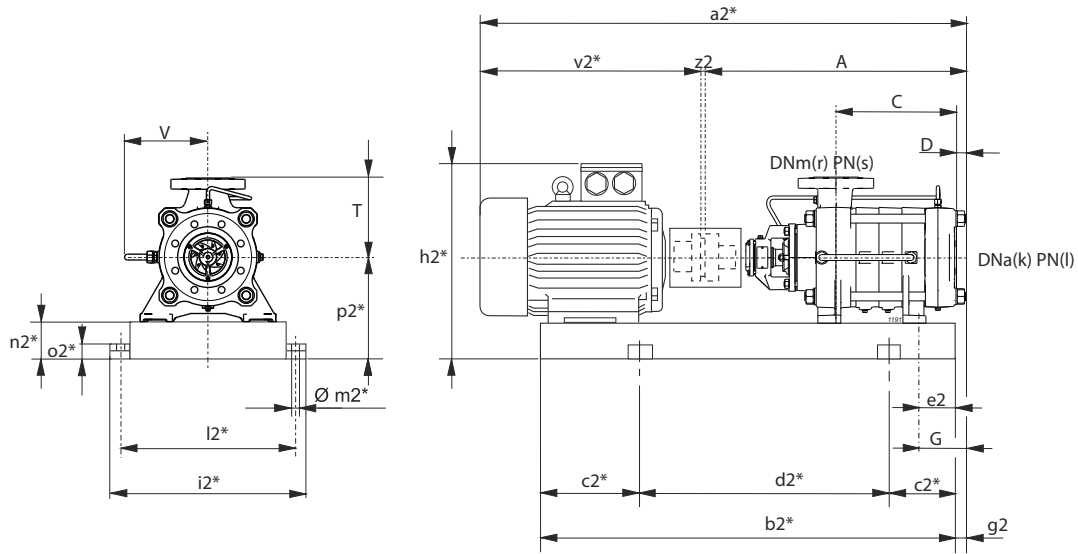

$g2 = G - e2$

* Valori indicativi in funzione della marca di motore utilizzato
Indicatives values according to the type of motor installed

Pump Pompe Pompa		Motor Moteur Motore		BGAMA	A	C	D	G	T	V	a2*	b2*	c2*	d2*	e2	h2*	i2*	k	l	l2*	m2*	n2*	o2*	p2*	r	s	v2*	z2	Weight Poids Peso	
Series Série Serie	Type Type Tipo	[kW]	Size Taille Grand.	Type Type Tipo	[mm]																									[kg]
PMA(S/H)	/10	7,5	132M	242/DL	1074	726,5	28,5	130	220	220	1568	1395	250	895	40	472	500	100	(1)	450	20	100	42	280	65	(2)	490	4	316	
PMA(S/H)	/10	11	160M	243/EM	1074	726,5	28,5	130	220	220	1705	1481	250	981	40	531	500	100	(1)	450	20	100	42	280	65	(2)	627	4	400	
PMA(S/H)	/10	15	160L	244/EM	1074	726,5	28,5	130	220	220	1705	1525	250	1025	40	531	500	100	(1)	450	20	100	42	280	65	(2)	627	4	413	
PMA(S/H)	65/11	7,5	132M	284/DL	1139	791,5	28,5	130	220	220	1633	1460	250	960	40	472	500	100	(1)	450	20	100	42	280	65	(2)	490	4	331	
PMA(S/H)	/11	11	160M	285/EM	1139	791,5	28,5	130	220	220	1770	1546	250	1046	40	531	500	100	(1)	450	20	100	42	280	65	(2)	627	4	416	
PMA(S/H)	/11	15	160L	286/EM	1139	791,5	28,5	130	220	220	1770	1590	250	1090	40	531	500	100	(1)	450	20	100	42	280	65	(2)	627	4	429	
PMA(S/H)	/11	18,5	180M	287/FM	1139	791,5	28,5	130	220	220	1808	1600	250	1100	40	550	500	100	(1)	450	20	100	42	280	65	(2)	665	4	463	
PMA(S/H)	65/12	7,5	132M	288/DL	1204	856,5	28,5	130	220	220	1698	1525	250	1025	40	472	500	100	(1)	450	20	100	42	280	65	(2)	490	4	346	
PMA(S/H)	/12	11	160M	289/EM	1204	856,5	28,5	130	220	220	1835	1611	250	1111	40	531	500	100	(1)	450	20	100	42	280	65	(2)	627	4	431	
PMA(S/H)	/12	15	160L	290/EM	1204	856,5	28,5	130	220	220	1835	1655	300	1055	40	531	500	100	(1)	450	20	100	42	280	65	(2)	627	4	444	
PMA(S/H)	/12	18,5	180M	291/FM	1204	856,5	28,5	130	220	220	1873	1665	300	1065	40	550	500	100	(1)	450	20	100	42	280	65	(2)	665	4	478	
PMA(S/H)	65/13	7,5	132M	292/DL	1269	921,5	28,5	130	220	220	1763	1590	250	1090	40	472	500	100	(1)	450	20	100	42	280	65	(2)	490	4	362	
PMA(S/H)	/13	11	160M	293/EM	1269	921,5	28,5	130	220	220	1900	1676	300	1076	40	531	500	100	(1)	450	20	100	42	280	65	(2)	627	4	446	
PMA(S/H)	/13	15	160L	294/EM	1269	921,5	28,5	130	220	220	1900	1720	300	1120	40	531	500	100	(1)	450	20	100	42	280	65	(2)	627	4	459	
PMA(S/H)	/13	18,5	180M	295/FM	1269	921,5	28,5	130	220	220	1938	1730	300	1130	40	550	500	100	(1)	450	20	100	42	280	65	(2)	665	4	492	
PMA(S/H)	65/14	11	160M	297/EM	1334	986,5	28,5	130	220	220	1965	1741	300	1141	40	531	500	100	(1)	450	20	100	42	280	65	(2)	627	4	462	
PMA(S/H)	/14	15	160L	298/EM	1334	986,5	28,5	130	220	220	1965	1785	300	1185	40	531	500	100	(1)	450	20	100	42	280	65	(2)	627	4	475	
PMA(S/H)	/14	18,5	180M	299/FM	1334	986,5	28,5	130	220	220	2003	1795	300	1195	40	550	500	100	(1)	450	20	100	42	280	65	(2)	665	4	509	
PMA(S/H)	/14	22	180L	300/FM	1334	986,5	28,5	130	220	220	2043	1833	300	1233	40	550	500	100	(1)	450	20	100	42	280	65	(2)	705	4	530	
PMA(S/H)	65/15	11	160M	505/EM	1399	1051,5	28,5	130	220	220	2030	1806	300	1206	40	531	500	100	(1)	450	20	100	42	280	65	(2)	627	4	477	
PMA(S/H)	/15	15	160L	506/EM	1399	1051,5	28,5	130	220	220	2030	1850	300	1250	40	531	500	100	(1)	450	20	100	42	280	65	(2)	627	4	490	
PMA(S/H)	/15	18,5	180M	507/FM	1399	1051,5	28,5	130	220	220	2068	1860	300	1260	40	550	500	100	(1)	450	20	100	42	280	65	(2)	665	4	525	
PMA(S/H)	/15	22	180L	508/FM	1399	1051,5	28,5	130	220	220	2108	1898	300	1298	40	550	500	100	(1)	450	20	100	42	280	65	(2)	705	4	545	
PMA(S/H)	65/16	15	160L	516/EM	1464	1116,5	28,5	130	220	220	2095	1915	300	1315	40	531	500	100	(1)	450	20	100	42	280	65	(2)	627	4	506	
PMA(S/H)	/16	18,5	180M	517/EM	1464	1116,5	28,5	130	220	220	2133	1925	300	1325	40	550	500	100	(1)	450	20	100	42	280	65	(2)	665	4	540	
PMA(S/H)	/16	22	180L	518/FM	1464	1116,5	28,5	130	220	220	2173	1963	350	1263	40	550	500	100	(1)	450	20	100	42	280	65	(2)	705	4	561	

BGAMA = Base and coupling

* = Indicatives values according to the type of motor installed

(1) PMA=25 bar PMAS=25 bar PMAH=40 bar

(2) PMA=40 bar PMAS=63 bar PMAH=100 bar

BGAMA = Socle et accouplement

* = Valeurs indicatives en fonction de la marque du moteur utilisé

(1) PMA=25 bar PMAS=25 bar PMAH=40 bar

(2) PMA=40 bar PMAS=63 bar PMAH=100 bar

BGAMA = Base giunto e coprigiunto

* = Valori indicativi in funzione della marca di motore utilizzato.

(1) PMA=25 bar PMAS=25 bar PMAH=40 bar

(2) PMA=40 bar PMAS=63 bar PMAH=100 bar