

Utilization field Champ d'utilisation Campo di utilizzo ≥ 65% η		
Stage number: compatibly with the maximum pressure. Nombre d'étages: compatible avec la pression maximum. Numero stadi: compatibilmente con la pressione massima di esercizio.		
Type Type Tipo	MIN.	MAX.
PMXT	2	5
PMXST	2	5
PMXHT	2	8
NB. For two-stage pumps only, reduce efficiency by one point. Diminuer le rendement d'un point seulement pour les pompes à deux étages. Solamente per le pompe a due stadi, ridurre di un punto il rendimento.		

Wet moment of inertia J Moment d'inertie J mouillé Momento d'inerzia J bagnato J=¼PD ² · [kg m ²]		
Impeller type Roue type Girante tipo	PMX(S/H)T125/1	For each additional stage Pour chaque étage en plus Per ogni stadio in più
Stainless steel Acier inox Acciaio inox	0,1011	0,0880

Maximum permissible power Puissances maximums admissibles Massime potenze ammissibili	
Type Type Tipo	N/n MAX.
PMXT	0,25
PMXST	0,25
PMXHT	0,25
For seal limits and calculation formulas of the maximum permissible powers, see technical data section. Consulter la section Données techniques pour connaître les limites des joints et les formules pour le calcul des puissances maximales admises. Per i limiti tenute e le formule di calcolo delle massime potenze ammissibili, vedere sezione dati tecnici.	

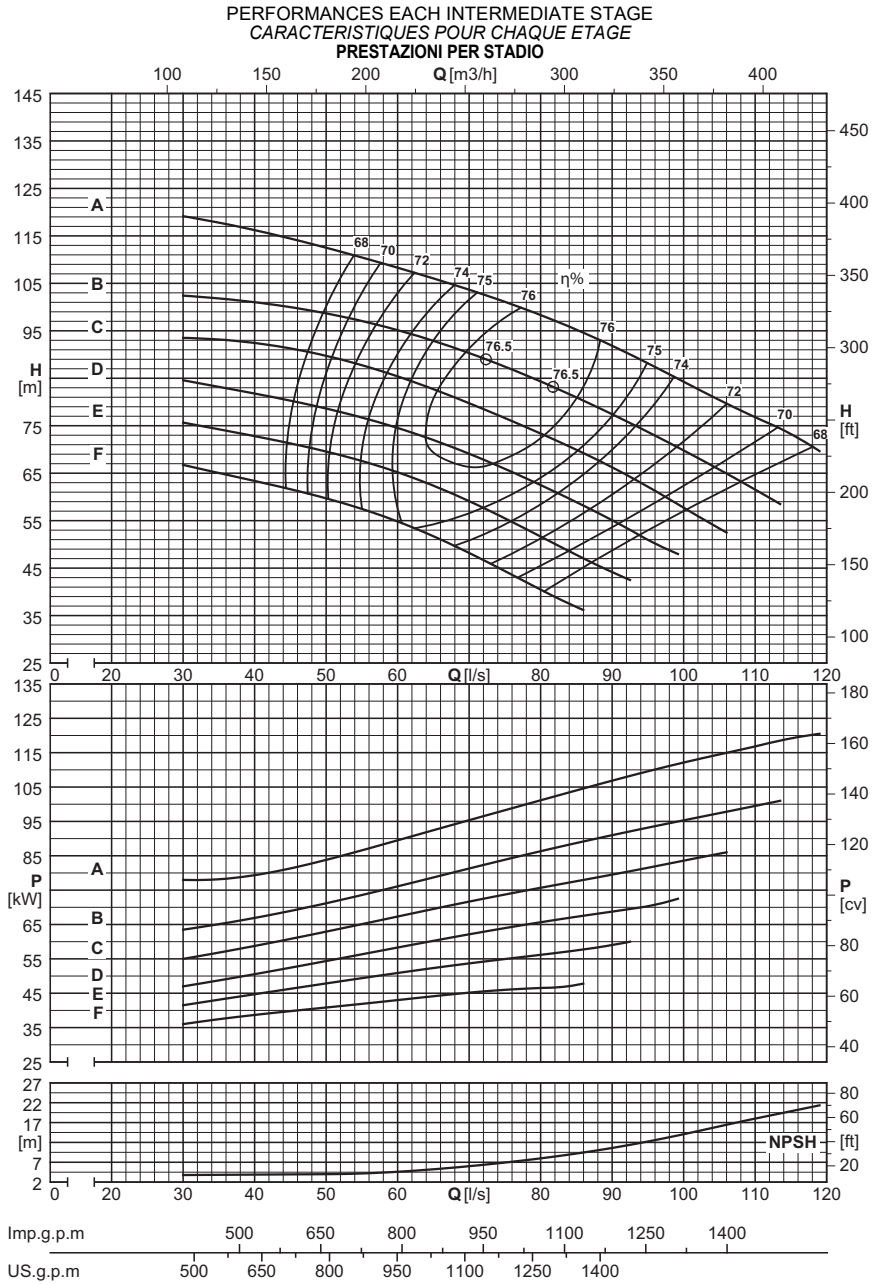

Dna x DNm	Impeller type Roue type Girante tipo	Capacity - Debit - Portata																						
		[l/s]	0	40	44	48	52	56	60	64	68	72	76	80	84	88	92	96	100	104	108	112		
		[m ³ /h]	0	144	158,4	172,8	187,2	201,6	216	230,4	244,8	259,2	273,6	288	302,4	316,8	331,2	345,6	360	374,4	388,8	403,2		
		[l/min]	0	2400	2640	2880	3120	3360	3600	3840	4080	4320	4560	4800	5040	5280	5520	5760	6000	6240	6480	6720		

		PMX(S/H)T125/1																						
150x125	F	[m]	69	61	62	60	57	57	54	52	49,5	47	43,5	40,5	37,5	35,5								
150x125	F	[kW]		39,5	39	40,5	42	42	43,5	43,5	44,5	46	45,5	46,5	47,5	49								
150x125	E	[m]	79	72	70	68	69	67	65	62	60	57	54	51	49	45,5	42,5	41						
150x125	E	[kW]		45	46,5	48,5	48	49,5	51	52,5	52,5	54	55	56,5	58	58	59,5	62,5						
150x125	D	[m]	88	83	81	79	77	75	73	71	69	68	65	62	59	56	53	50	47,5					
150x125	D	[kW]		49,5	51,5	53,5	55	57,5	59	60,5	62	62	63,5	65	66,5	69	69,5	71	73					
150x125	C	[m]	100		87	87	86	85	83	81	79	77	75	72	70	67	64	61	58	54	51			
150x125	C	[kW]			62,5	64	65,5	67	68,5	70,5	72	73,5	75	76	78	79	81	82	84	86	87			
150x125	B	[m]	112		98	98	98	97	96	94	92	90	85	83	81	78	75	72	69	66	62	59		
150x125	B	[kW]			69,5	70,5	72	74	75	77	79	81	85	87	89	90	92	93	95	96	98	99		
150x125	A	[m]	130			114	114	113	105	105	104	102	101	99	96	92	90	87	84	81	78	75		
150x125	A	[kW]				81	83	85	91	92	94	96	98	100	102	106	108	110	112	113	114	116		

		NPSH																						
		[m]		3,9	3,9	4	4	4,2	4,6	5	5,7	6,4	7,1	8	9	10,1	11,2	12,6	14,1	15,8	17,5	19		

Overall dimensions and weights
 Dimensions d'encombrement et poids
 Dimensioni di ingombro e pesi

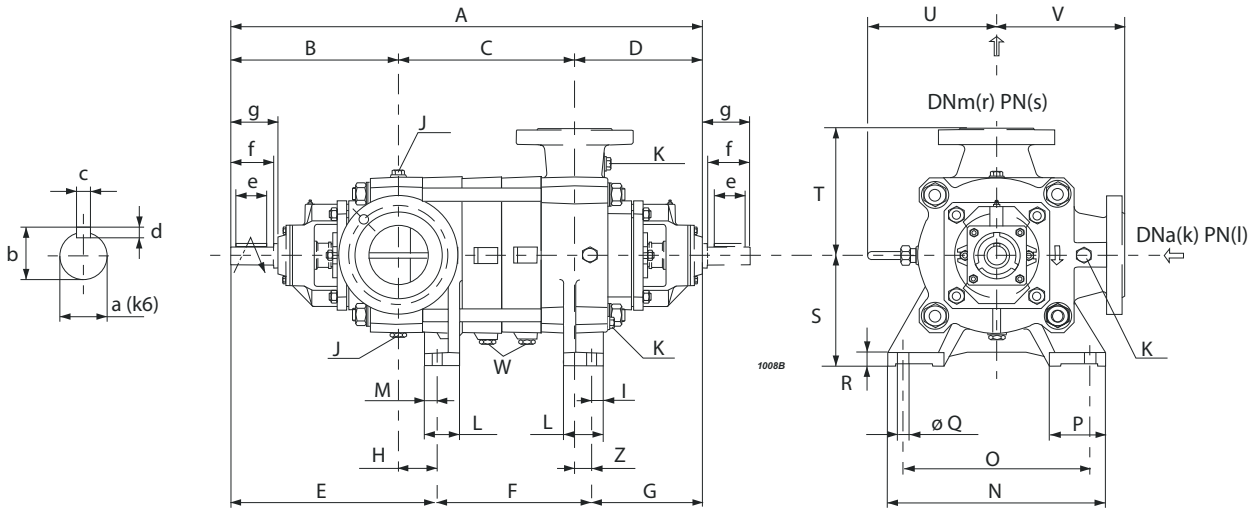

Series Série Serie	Type Type Tipo	A	B	C	D	E	F	G	H	S	T	U	V	Z	Weight Poids Peso
		[mm]													
PMX(S/H)T	125/2	1033	451	245	337	539	200	294	88	280	320	326	320	43	462
PMX(S/H)T	125/3	1133	451	345	337	539	300	294	88	280	320	326	320	43	514
PMX(S/H)T	125/4	1233	451	445	337	539	400	294	88	280	320	326	320	43	565
PMX(S/H)T	125/5	1333	451	545	337	539	500	294	88	280	320	326	320	43	616
PMX(S/H)T	125/6	1433	451	645	337	539	600	294	88	280	320	326	320	43	667
PMX(S/H)T	125/7	1533	451	745	337	539	700	294	88	280	320	326	320	43	718
PMX(S/H)T	125/8	1633	451	845	337	539	800	294	88	280	320	326	320	43	770
PMX(S/H)T	125/9	1733	451	945	337	539	900	294	88	280	320	326	320	43	821
PMX(S/H)T	125/10	1833	451	1045	337	539	1000	294	88	280	320	326	320	43	872

Foot dimensions Dimensions des pieds Dimensioni dei piedi							
I	L	M	N	O	P	Q	R
[mm]							
30	100	29,5	570	460	145	24	35

Shaft projection Saille d'arbre Sporgenza d'albero							
a	b	c	d	e	f	g	
[mm]							
45	48,5	14	9	100	110	125	

Type Type Tipo	Flanges Brides Flange			
	(k) DNa	(l) PN	(r) DNm	(s) PN
	[mm]	[bar]	[mm]	[bar]
PMXT	150	25	125	40
PMXST	150	25	125	63
PMXHT	150	40	125	100

Plugs Bouchons Tappi		
J	K	W
G3/4	G1/2	G1/4

Selection - dimensions and weights for base mounted electric pumps
 Sélection - dimensions et poids des électropompes sur socle
 Selezione - dimensioni e pesi elettropompe su base

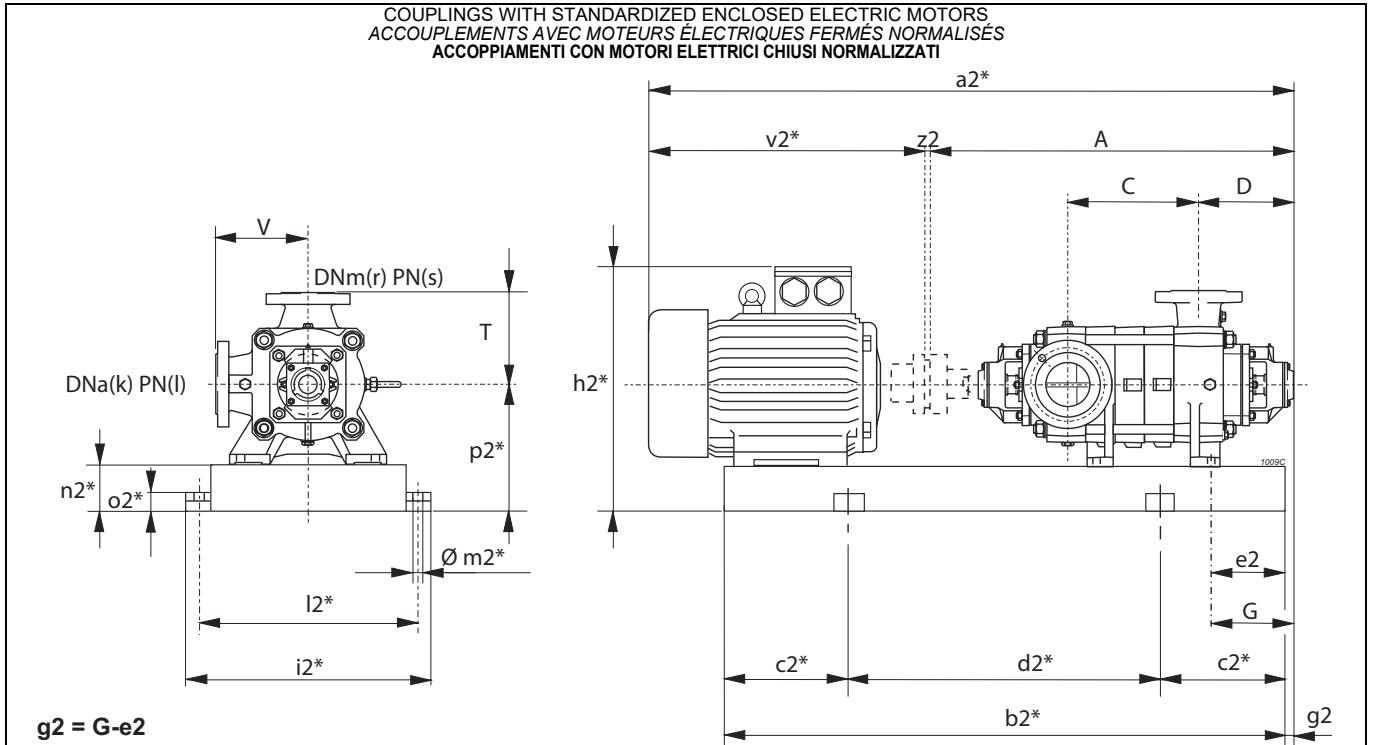

$g2 = G - e2$

* Valori indicativi in funzione della marca di motore utilizzato
 Indicatives values according to the type of motor installed

Pump Pompe Pompa		Motor Moteur Motore		BGAM	A	C	D	G	T	V	a2*	b2*	c2*	d2*	e2	h2*	i2*	k	l	l2*	m2*	n2*	o2*	p2*	r	s	v2*	z2	Weight Poids Peso		
Series Série Serie	Type Type Tipo	[kW]	Size Taille Grand.	Type Type Tipo	[mm]																										[kg]
PMX(S/H)T	125/2	110	315S	800/IR	1033	245	337	294	320	320	2218	1695	300	1095	90	1030	780	150	(1)	730	22	160	50	475	125	(2)	1181	4	1543		
PMX(S/H)T	/2	132	315M	335/IR	1033	245	337	294	320	320	2328	1805	300	1205	90	1030	780	150	(1)	730	22	160	50	475	125	(2)	1291	4	1619		
PMX(S/H)T	/2	160	315L	335/IR	1033	245	337	294	320	320	2328	1805	300	1205	90	1030	780	150	(1)	730	22	160	50	475	125	(2)	1291	4	1697		
PMX(S/H)T	/2	200	315L	336/IE4/LR	1033	245	337	294	320	320	2418	1895	300	1295	198	1030	780	150	(1)	730	22	160	50	475	125	(2)	1381	4	1831		
PMX(S/H)T	/2	250	355M	337/LR	1033	245	337	294	320	320	2563	1879	300	1279	110	1136	880	150	(1)	830	22	180	50	535	125	(2)	1526	4	2244		
PMX(S/H)T	/2	280	355M	4003/MR	1033	245	337	294	320	320	2563	1879	300	1279	110	1136	880	150	(1)	830	22	180	50	535	125	(2)	1526	4	2373		
PMX(S/H)T	125/3	160	315L	338/LR	1133	345	337	294	320	320	2428	1905	300	1305	90	1030	780	150	(1)	730	22	160	50	475	125	(2)	1291	4	1753		
PMX(S/H)T	/3	200	315L	338/IE4/LR	1133	345	337	294	320	320	2518	1995	350	1295	198	1030	780	150	(1)	730	22	160	50	475	125	(2)	1381	4	1882		
PMX(S/H)T	/3	250	355L	339/LR	1133	345	337	294	320	320	2663	2049	350	1349	110	1136	880	150	(1)	830	22	180	50	535	125	(2)	1526	4	2298		
PMX(S/H)T	/3	280	355L	339/LR	1133	345	337	294	320	320	2663	2049	350	1349	110	1136	880	150	(1)	830	22	180	50	535	125	(2)	1526	4	2423		
PMX(S/H)T	/3	315	355L	339/MR	1133	345	337	294	320	320	2663	2049	350	1349	110	1136	880	150	(1)	830	22	180	50	535	125	(2)	1526	4	2427		
PMX(S/H)T	/3	355	355L	339/MR	1133	345	337	294	320	320	2663	2049	350	1349	110	1136	880	150	(1)	830	22	180	50	535	125	(2)	1526	4	2417		
PMX(S/H)T	125/4	200	315L	806/IE4/LR	1233	445	337	294	320	320	2618	2095	350	1395	198	1030	780	150	(1)	730	22	160	50	475	125	(2)	1381	4	1933		
PMX(S/H)T	/4	250	355M	340/LR	1233	445	337	294	320	320	2763	2079	350	1379	110	1136	880	150	(1)	830	22	180	50	535	125	(2)	1526	4	2349		
PMX(S/H)T	/4	280	355L	340/MR	1233	445	337	294	320	320	2763	2149	350	1449	110	1136	880	150	(1)	830	22	180	50	535	125	(2)	1526	4	2478		
PMX(S/H)T	/4	315	355L	340/MR	1233	445	337	294	320	320	2763	2149	350	1449	110	1136	880	150	(1)	830	22	180	50	535	125	(2)	1526	4	2478		
PMX(S/H)T	/4	355	355L	340/MR	1233	445	337	294	320	320	2763	2149	350	1449	110	1136	880	150	(1)	830	22	180	50	535	125	(2)	1526	4	2468		
PMX(S/H)T	125/5	280	355L	341/MR	1333	545	337	294	320	320	2863	2249	350	1549	110	1136	880	150	(1)	830	22	180	50	535	125	(2)	1526	4	2530		
PMX(S/H)T	/5	315	355L	341/MR	1333	545	337	294	320	320	2863	2249	350	1549	110	1136	880	150	(1)	830	22	180	50	535	125	(2)	1526	4	2530		
PMX(S/H)T	/5	355	355L	341/MR	1333	545	337	294	320	320	2863	2249	350	1549	110	1136	880	150	(1)	830	22	180	50	535	125	(2)	1526	4	2520		
PMX(H)T	125/6	315	355L	4000/MR	1433	645	337	294	320	320	2963	2349	400	1549	110	1136	880	150	(1)	830	22	180	50	535	125	(2)	1526	4	2581		
PMX(H)T	/6	355	355L	4000/MR	1433	645	337	294	320	320	2963	2349	400	1549	110	1136	880	150	(1)	830	22	180	50	535	125	(2)	1526	4	2571		
PMX(H)T	125/7	355	355L	4001/MR	1533	745	337	294	320	320	3063	2449	400	1649	110	1136	880	150	(1)	830	22	180	50	535	125	(2)	1526	4	2623		

Contact the sales network for couplings exceeding 355 kW.

Pour des accouplements supérieurs à 355 kW, contacter notre réseau de vente.

Per accoppiamenti superiori a 355 kW, contattare la rete di vendita.

BGAM = Base and coupling

BGAM = Socle et accouplement

BGAM = Base giunto e coprigiunto

* = Indicatives values according to the type of motor installed.

* = Valeurs indicatives en fonction de la marque du moteur utilisé.

* = Valori indicativi in funzione della marca di motore utilizzato.

○ Motor in IE4 efficiency class according to EU REGULATION 2019/1781. Available in other efficiency classes for non-EU markets.

○ Moteur en classe de rendement IE4 conformément au RÈGLEMENT UE2019/1781. Disponibilité en différentes classes de rendement pour les marchés hors UE.

○ Motore in classe di efficienza IE4 in conformità al REGOLAMENTO UE2019/1781. Disponibili in altre classi di efficienza per mercati extra UE.

- (1) PMXT=25 bar PMXST=25 bar PMXHT=40 bar
- (2) PMXT=40 bar PMXST=63 bar PMXHT=100 bar

- (1) PMXT=25 bar PMXST=25 bar PMXHT=40 bar
- (2) PMXT=40 bar PMXST=63 bar PMXHT=100 bar

- (1) PMXT=25 bar PMXST=25 bar PMXHT=40 bar
- (2) PMXT=40 bar PMXST=63 bar PMXHT=100 bar

Selection - dimensions and weights for base mounted electric pumps
 Sélection - dimensions et poids des électropompes sur socle
 Selezione - dimensioni e pesi elettropompe su base

COUPLINGS WITH STANDARDIZED ENCLOSED ELECTRIC MOTORS
 ACCOUPLEMENTS AVEC MOTEURS ÉLECTRIQUES FERMÉS NORMALISÉS
 ACCOPIAMENTI CON MOTORI ELETTRICI CHIUSI NORMALIZZATI

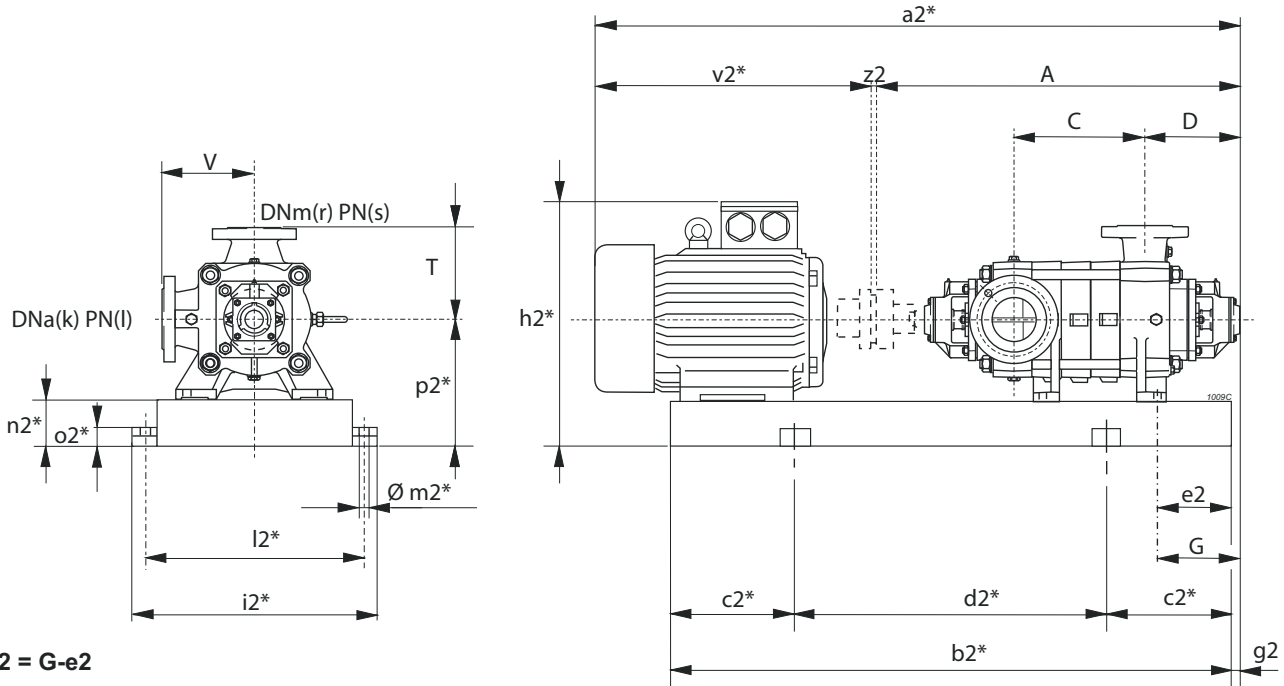

* Valori indicativi in funzione della marca di motore utilizzato
 Indicatives values according to the type of motor installed

Pump Pompe Pompa	Motor Moteur Motore	BGAM	A	C	D	G	T	V	a2*	b2*	c2*	d2*	e2	h2*	i2*	k	l	l2*	m2*	n2*	o2*	p2*	r	s	v2*	z2	Weight Poids Peso	
Series Série Serie	Type Type Tipo	[kW]	Size Taille Grand.	Type Type Tipo	[mm]																				[kg]			
PMX(S/H)T	125/2	15	160L	345/EP	1033	245	337	294	320	1664	1340	200	940	60	671	700	150	(1)	650	20	140	42	420	125	(2)	627	4	684
PMX(S/H)T	/2	18,5	180M	346/FP	1033	245	337	294	320	1702	1350	250	850	60	690	700	150	(1)	650	20	140	42	420	125	(2)	665	4	765
PMX(S/H)T	/2	22	180L	347/FP	1033	245	337	294	320	1742	1388	250	888	60	690	700	150	(1)	650	20	140	42	420	125	(2)	705	4	786
PMX(S/H)T	/2	30	200L	348/GP	1033	245	337	294	320	1795	1423	250	923	60	720	700	150	(1)	650	20	140	42	420	125	(2)	758	4	821
PMX(S/H)T	/2	37	225S	4008/HR	1033	245	337	294	320	1830	1454	250	954	60	750	700	150	(1)	650	20	140	42	420	125	(2)	793	4	836
PMX(S/H)T	125/3	22	180L	849/FP	1133	345	337	294	320	1842	1488	250	988	60	690	700	150	(1)	650	20	140	42	420	125	(2)	705	4	836
PMX(S/H)T	/3	30	200L	349/GP	1133	345	337	294	320	1895	1523	250	1023	60	720	700	150	(1)	650	20	140	42	420	125	(2)	758	4	871
PMX(S/H)T	/3	37	225S	350/HR	1133	345	337	294	320	1930	1554	250	1054	60	750	700	150	(1)	650	20	140	42	420	125	(2)	793	4	886
PMX(S/H)T	/3	45	225M	351/HR	1133	345	337	294	320	1955	1579	250	1079	60	750	700	150	(1)	650	20	140	42	420	125	(2)	818	4	929
PMX(S/H)T	/3	55	250M	4009/IR	1133	345	337	294	320	2017	1621	250	1121	60	795	700	150	(1)	650	20	140	42	420	125	(2)	880	4	1052
PMX(S/H)T	125/4	30	200L	352/GP	1233	445	337	294	320	1995	1623	250	1123	60	720	700	150	(1)	650	20	140	42	420	125	(2)	758	4	921
PMX(S/H)T	/4	37	225S	471/HR	1233	445	337	294	320	2030	1654	300	1054	60	750	700	150	(1)	650	20	140	42	420	125	(2)	793	4	937
PMX(S/H)T	/4	45	225M	472/HR	1233	445	337	294	320	2055	1679	300	1079	60	750	700	150	(1)	650	20	140	42	420	125	(2)	818	4	979
PMX(S/H)T	/4	55	250M	473/IR	1233	445	337	294	320	2117	1721	300	1121	60	795	700	150	(1)	650	20	140	42	420	125	(2)	880	4	1102
PMX(S/H)T	/4	75	280S	474/IR	1233	445	337	294	320	2250	1768	300	1168	60	815	700	150	(1)	650	20	140	42	420	125	(2)	1013	4	1244
PMX(S/H)T	125/5	37	225S	813/HR	1333	545	337	294	320	2130	1754	300	1154	60	750	700	150	(1)	650	20	140	42	420	125	(2)	793	4	987
PMX(S/H)T	/5	45	225M	475/HR	1333	545	337	294	320	2155	1779	300	1179	60	750	700	150	(1)	650	20	140	42	420	125	(2)	818	4	1029
PMX(S/H)T	/5	55	250M	476/IR	1333	545	337	294	320	2217	1821	300	1221	60	795	700	150	(1)	650	20	140	42	420	125	(2)	880	4	1153
PMX(S/H)T	/5	75	280S	477/IR	1333	545	337	294	320	2350	1868	300	1268	60	815	700	150	(1)	650	20	140	42	420	125	(2)	1013	4	1294
PMX(S/H)T	/5	90	280M	4005/LR	1333	545	337	294	320	2401	1919	300	1319	60	815	700	150	(1)	650	20	140	42	420	125	(2)	1064	4	1363
PMX(S/H)T	125/6	45	225M	478/HR	1433	645	337	294	320	2255	1879	300	1279	60	750	700	150	(1)	650	20	140	42	420	125	(2)	818	4	1080
PMX(S/H)T	/6	55	250M	479/IR	1433	645	337	294	320	2317	1921	300	1321	60	795	700	150	(1)	650	20	140	42	420	125	(2)	880	4	1203
PMX(S/H)T	/6	75	280S	480/IR	1433	645	337	294	320	2450	1968	350	1268	60	815	700	150	(1)	650	20	140	42	420	125	(2)	1013	4	1344
PMX(S/H)T	/6	90	280M	481/LR	1433	645	337	294	320	2501	2019	350	1319	60	815	700	150	(1)	650	20	140	42	420	125	(2)	1064	4	1414
PMX(S/H)T	/6	110	315S	498/LR	1433	645	337	294	320	2648	2125	350	1425	90	1030	780	150	(1)	730	22	160	50	475	125	(2)	1211	4	1747
PMX(S/H)T	125/7	55	250M	482/IR	1533	745	337	294	320	2417	2021	350	1321	60	795	700	150	(1)	650	20	140	42	420	125	(2)	880	4	1253
PMX(S/H)T	/7	75	280S	483/IR	1533	745	337	294	320	2550	2068	350	1368	60	815	700	150	(1)	650	20	140	42	420	125	(2)	1013	4	1395
PMX(S/H)T	/7	90	280M	484/LR	1533	745	337	294	320	2601	2119	350	1419	60	815	700	150	(1)	650	20	140	42	420	125	(2)	1064	4	1464
PMX(S/H)T	/7	110	315S	485/LR	1533	745	337	294	320	2748	2225	350	1525	90	1030	780	150	(1)	730	22	160	50	475	125	(2)	1211	4	1798

BGAM = Base and coupling

* = Indicatives values according to the type of motor installed.

○ Motor in IE4 efficiency class according to EU REGULATION 2019/1781. Available in other efficiency classes for non-EU markets.

(1) PMXT=25 bar PMXST=25 bar PMXHT=40 bar

(2) PMXT=40 bar PMXST=63 bar PMXHT=100 bar

BGAM = Socle et accouplement

* = Valeurs indicatives en fonction de la marque du moteur utilisé.

○ Moteur en classe de rendement IE4 conformément au RÈGLEMENT UE2019/1781. Disponible en différentes classes de rendement pour les marchés hors UE.

(1) PMXT=25 bar PMXST=25 bar PMXHT=40 bar

(2) PMXT=40 bar PMXST=63 bar PMXHT=100 bar

BGAM = Base giunto e coprigiunto

* = Valori indicativi in funzione della marca di motore utilizzato.

○ Motore in classe di efficienza IE4 in conformità al REGOLAMENTO UE2019/1781. Disponibili in altre classi di efficienza per mercati extra UE.

(1) PMXT=25 bar PMXST=25 bar PMXHT=40 bar

(2) PMXT=40 bar PMXST=63 bar PMXHT=100 bar

Selection - dimensions and weights for base mounted electric pumps
 Sélection - dimensions et poids des électropompes sur socle
 Selezione - dimensioni e pesi elettropompe su base

COUPLINGS WITH STANDARDIZED ENCLOSED ELECTRIC MOTORS
 ACCOUPLEMENTS AVEC MOTEURS ÉLECTRIQUES FERMÉS NORMALISÉS
 ACCOPIAMENTI CON MOTORI ELETTRICI CHIUSI NORMALIZZATI

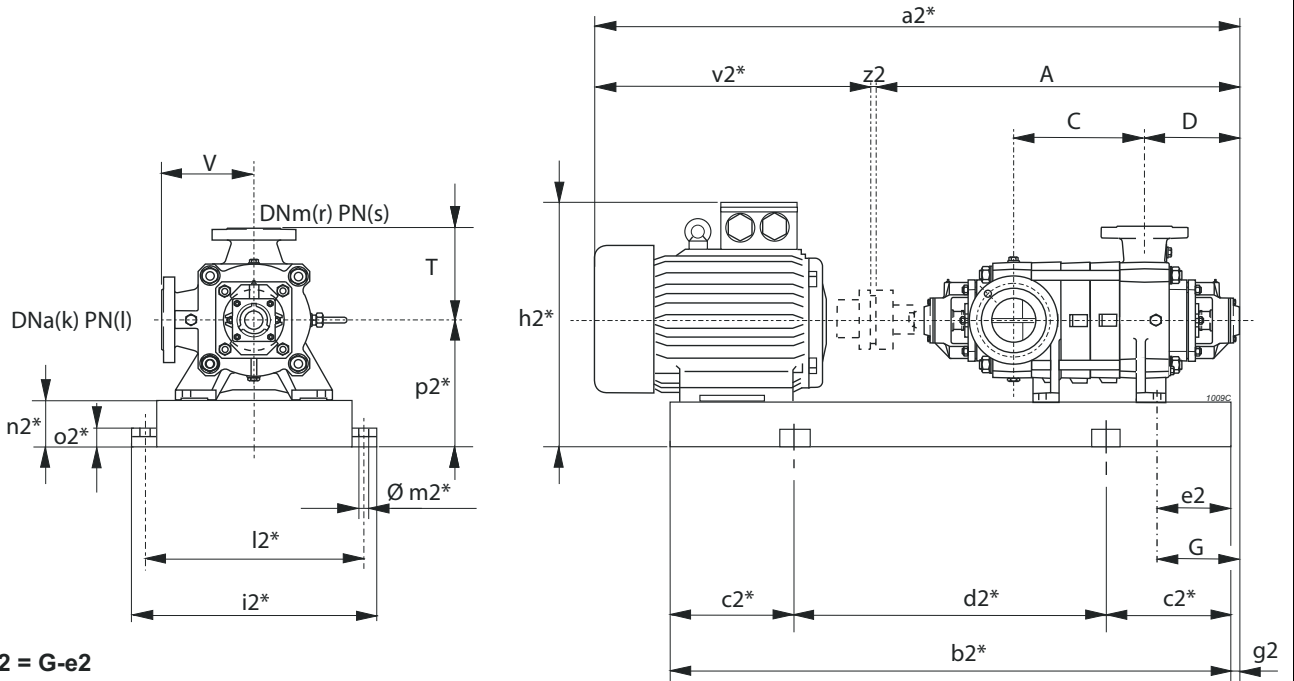

g2 = G-e2

* Valori indicativi in funzione della marca di motore utilizzato
 Indicatives values according to the type of motor installed

Pump Pompe Pompa		Motor Moteur Motore		BGAM	A	C	D	G	T	V	a2*	b2*	c2*	d2*	e2	h2*	i2*	k	l	l2*	m2*	n2*	o2*	p2*	r	s	v2*	z2	Weight Poids Peso
Series Série Serie	Type Type Tipo	[kW]	Size Taille Grand.	Type Type Tipo	[mm]																								[kg]
PMX(S/H)T	/7	132	315M	4007/MR	1533	745	337	294	320	320	2858	2284	400	1484	90	1030	780	150	(1)	730	22	160	50	475	125	(2)	1321	4	1924
PMX(S/H)T	125/8	55	250M	818/IR	1633	845	337	294	320	320	2517	2121	350	1421	60	795	700	150	(1)	650	20	140	42	420	125	(2)	880	4	1303
PMX(S/H)T	/8	75	280S	486/IR	1633	845	337	294	320	320	2650	2168	350	1468	60	815	700	150	(1)	650	20	140	42	420	125	(2)	1013	4	1445
PMX(S/H)T	/8	90	280M	487/LR	1633	845	337	294	320	320	2701	2219	350	1519	60	815	700	150	(1)	650	20	140	42	420	125	(2)	1064	4	1514
PMX(S/H)T	/8	110	315S	488/LR	1633	845	337	294	320	320	2848	2325	400	1525	90	1030	780	150	(1)	730	22	160	50	475	125	(2)	1211	4	1848
PMX(S/H)T	/8	132	315M	489/MR	1633	845	337	294	320	320	2958	2384	400	1584	90	1030	780	150	(1)	730	22	160	50	475	125	(2)	1321	4	1975
PMX(S/H)T	125/9	75	280S	490/IR	1733	945	337	294	320	320	2750	2268	400	1468	60	815	700	150	(1)	650	20	140	42	420	125	(2)	1013	4	1495
PMX(S/H)T	/9	90	280M	491/LR	1733	945	337	294	320	320	2801	2319	400	1519	60	815	700	150	(1)	650	20	140	42	420	125	(2)	1064	4	1564
PMX(S/H)T	/9	110	315S	492/LR	1733	945	337	294	320	320	2948	2425	400	1625	90	1030	780	150	(1)	730	22	160	50	475	125	(2)	1211	4	1899
PMX(S/H)T	/9	132	315M	493/MR	1733	945	337	294	320	320	3058	2535	400	1735	90	1030	780	150	(1)	730	22	160	50	475	125	(2)	1321	4	2027
PMX(S/H)T	/9	160	315L	493/MR	1733	945	337	294	320	320	3058	2535	400	1735	90	1030	780	150	(1)	730	22	160	50	475	125	(2)	1321	4	2122
PMX(S/H)T	125/10	75	280S	494/IR	1833	1045	337	294	320	320	2850	2368	400	1568	60	815	700	150	(1)	650	20	140	42	420	125	(2)	1013	4	1545
PMX(S/H)T	/10	90	280M	495/LR	1833	1045	337	294	320	320	2901	2419	400	1619	60	815	700	150	(1)	650	20	140	42	420	125	(2)	1064	4	1614
PMX(S/H)T	/10	110	315S	496/LR	1833	1045	337	294	320	320	3048	2525	400	1725	90	1030	780	150	(1)	730	22	160	50	475	125	(2)	1211	4	1950
PMX(S/H)T	/10	132	315M	497/MR	1833	1045	337	294	320	320	3158	2635	450	1735	90	1030	780	150	(1)	730	22	160	50	475	125	(2)	1321	4	2078
PMX(S/H)T	/10	160	315L	497/MR	1833	1045	337	294	320	320	3158	2635	450	1735	90	1030	780	150	(1)	730	22	160	50	475	125	(2)	1321	4	2173
PMX(S/H)T	/10	200	315L	497/IE4/MR	1833	1045	337	294	320	320	3248	2725	450	1825	198	1030	780	150	(1)	730	22	160	50	475	125	(2)	1411	4	2314

BGAM = Base and coupling

* = Indicatives values according to the type of motor installed.

○ Motor in IE4 efficiency class according to EU REGULATION 2019/1781. Available in other efficiency classes for non-EU markets.

- (1) PMXT=25 bar PMXST=25 bar PMXHT=40 bar
 (2) PMXT=40 bar PMXST=63 bar PMXHT=100 bar

BGAM = Socle et accouplement

* = Valeurs indicatives en fonction de la marque du moteur utilisé.

○ Moteur en classe de rendement IE4 conformément au RÈGLEMENT UE2019/1781. Disponibilité en différentes classes de rendement pour les marchés hors UE.

- (1) PMXT=25 bar PMXST=25 bar PMXHT=40 bar
 (2) PMXT=40 bar PMXST=63 bar PMXHT=100 bar

BGAM = Base giunto e coprigiunto

* = Valori indicativi in funzione della marca di motore utilizzato.

○ Motore in classe di efficienza IE4 in conformità al REGOLAMENTO UE2019/1781. Disponibili in altre classi di efficienza per mercati extra UE.

- (1) PMXT=25 bar PMXST=25 bar PMXHT=40 bar
 (2) PMXT=40 bar PMXST=63 bar PMXHT=100 bar