

# PML 125

1750 n [min<sup>-1</sup>]



Utilization field Champ d'utilisation Campo di utilizzo ≥ 67% η		
Stage number: compatibly with the maximum pressure. Nombre d'étages: compatible avec la pression maximum. Numero stadi: compatibilmente con la pressione massima di esercizio.		
Type Type Tipo	MIN.	MAX.
PML	2	10
PMLS	2	10
PMLH	2	10
NB. For two-stage pumps only, reduce efficiency by one point. Diminuer le rendement d'un point seulement pour les pompes à deux étages. Solamente per le pompe a due stadi, ridurre di un punto il rendimento.		

Wet moment of inertia J Moment d'inertie J mouillé Momento d'inerzia J bagnato J=¼PD <sup>2</sup> - [kg m <sup>2</sup> ]		
Impeller type Roue type Girante tipo	PML(S/H)125/1	For each additional stage Pour chaque étage en plus Per ogni stadio in più
Cast iron Fonte Ghisa	0,096	0,084
Bronze Bronze Bronzo	0,1043	0,0923

Maximum permissible power Puissances maximums admissibles Massime potenze ammissibili	
Type / Type / Tipo	N/n MAX.
PML	0,18
PMLS	0,18
PMLH	0,25
For seal limits and calculation formulas of the maximum permissible powers, see technical data section. Consulter la section Données techniques pour connaître les limites des joints et les formules pour le calcul des puissances maximales admises. Per i limiti tenute e le formule di calcolo delle massime potenze ammissibili, vedere sezione dati tecnici.	

PERFORMANCES EACH INTERMEDIATE STAGE  
CARACTERISTIQUES POUR CHAQUE ETAGE  
PRESTAZIONI PER STADIO

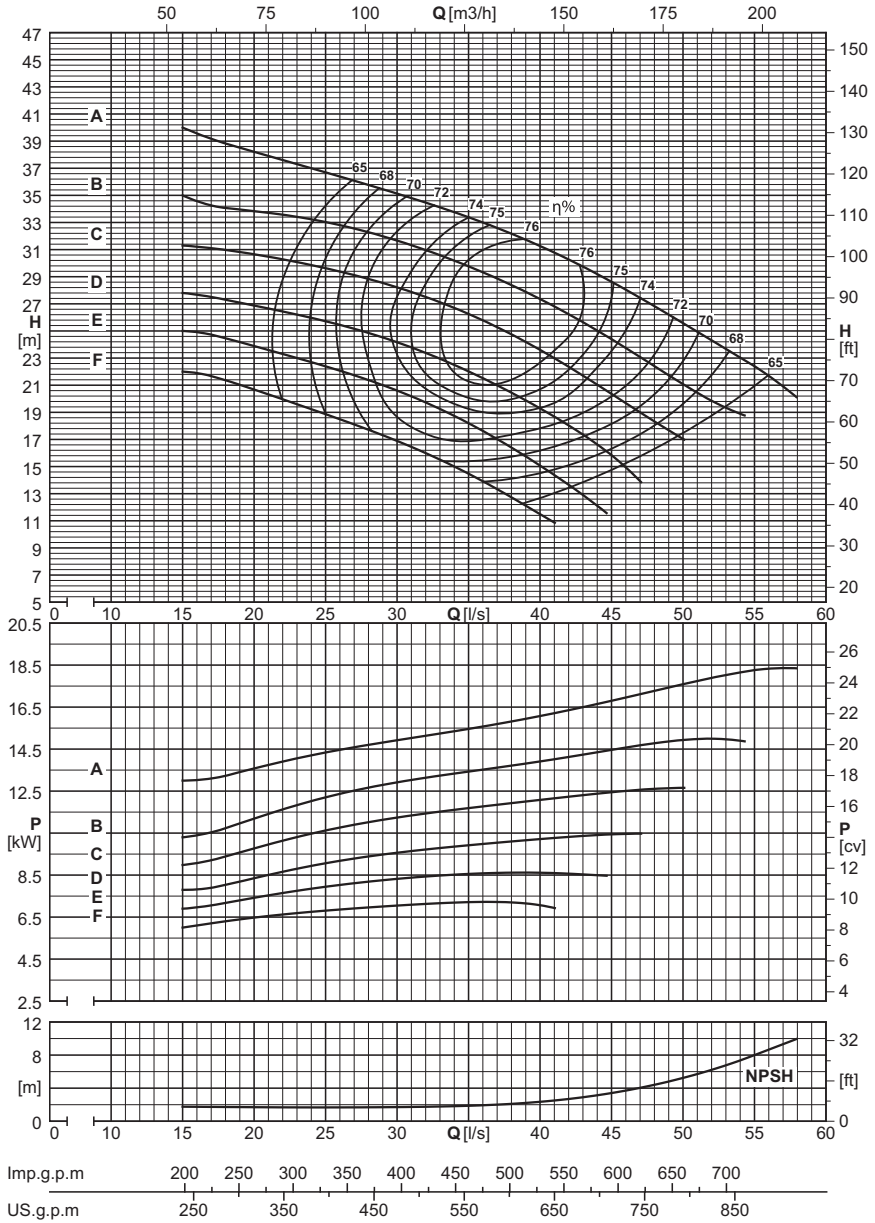

Dna x Dnm		Impeller type / Roue type / Girante tipo	[l/s]	0	22	24	26	28	30	32	34	36	38	40	42	44	46	48	50	52	54	56
			[m <sup>3</sup> /h]	0	79,2	86,4	93,6	100,8	108	115,2	122,4	129,6	136,8	144	151,2	158,4	165,6	172,8	180	187,2	194,4	201,6
			[l/min]	0	1320	1440	1560	1680	1800	1920	2040	2160	2280	2400	2520	2640	2760	2880	3000	3120	3240	3360

		PML(S/H)125/1																					
150x125	F	[m]	24	20	19,5	18,5	17,5	17	16,5	15,5	14,5	12,5	11,5										
150x125	F	[kW]		6,7	6,6	6,9	7,1	7	7,2	7,2	7,3	7,1	7,2										
150x125	E	[m]	27	22,5	23	22	21	21	20	18,5	17,5	16,5	15	14									
150x125	E	[kW]		7,8	7,8	8	8,3	8,2	8,4	8,6	8,7	8,5	8,6	8,7									
150x125	D	[m]	30	26	25,5	26,5	25	24	23,5	22,5	21,5	20,5	19,5	19	16,5	15,5							
150x125	D	[kW]		8,7	9,1	9	9,3	9,5	9,7	10	10,1	10	10,2	10,3	10,5	10,6							
150x125	C	[m]	34	30,5	30	29,5	29	28	27,5	26,5	25,5	24,5	23,5	22,5	21	19,5	18,5	17,5	16,5				
150x125	C	[kW]		10	10,4	10,7	11	11,3	11,5	11,7	11,9	12,1	11,9	12,1	12,3	12,4	12,6	12,6	13,1				
150x125	B	[m]	38		32,5	32	32	31,5	30,5	30	29	28,5	27,5	26	25,5	23,5	22,5	21	20	19	18		
150x125	B	[kW]			12,3	12,6	12,9	13,1	13,3	13,4	13,6	13,8	14	14,1	14,4	14,6	14,8	14,9	14,9	14,8	15,5		
150x125	A	[m]	44,5			36,5	36,5	36	35	33	32,5	32	31	30,5	29	29	27	25,5	24,5	23	22		
150x125	A	[kW]				14,3	14,5	14,6	14,8	15,5	16	16	16	16	16,5	17	17	18	18	18,5	18,5		

		NPSH																					
	[m]		1,7	1,7	1,7	1,7	1,7	1,8	1,8	1,9	2,1	2,3	2,7	3,1	3,7	4,4	5,3	6,3	7,5	8,5			

Overall dimensions and weights  
 Dimensions d'encombrement et poids  
 Dimensioni di ingombro e pesi

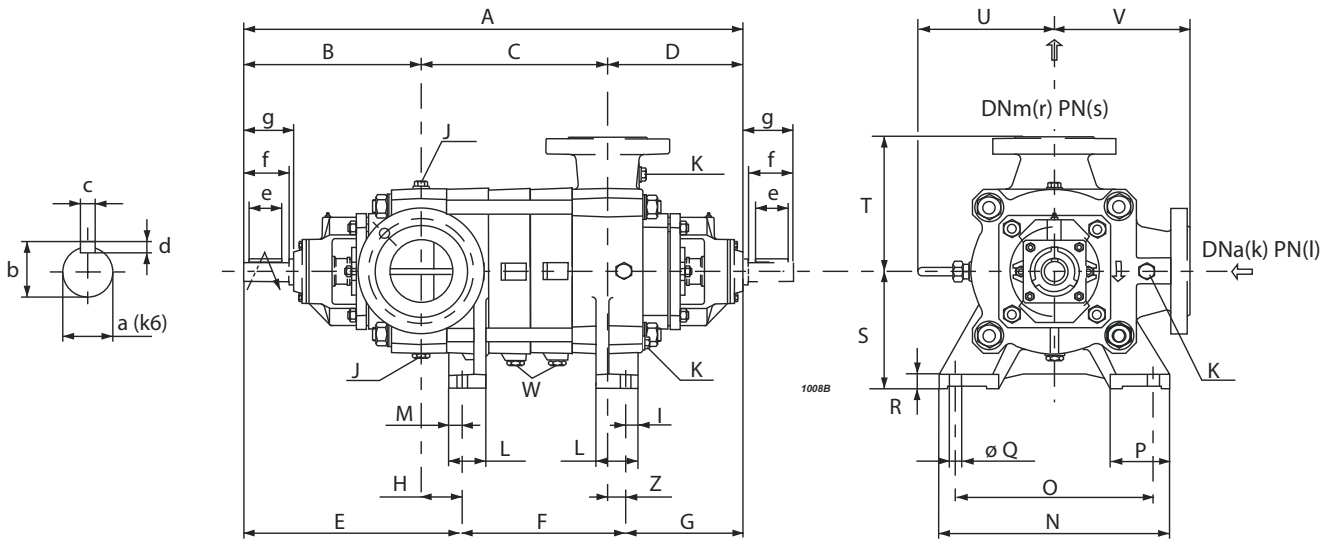

Series Série Serie	Type Type Tipo	A	B	C	D	E	F	G	H	S	T	U	V	Z	Weight Poids Peso
		[mm]													
PML(S/H)	125/2	1033	451	245	337	539	200	294	88	280	320	326	320	43	424
PML(S/H)	125/3	1133	451	345	337	539	300	294	88	280	320	326	320	43	471
PML(S/H)	125/4	1233	451	445	337	539	400	294	88	280	320	326	320	43	518
PML(S/H)	125/5	1333	451	545	337	539	500	294	88	280	320	326	320	43	565
PML(S/H)	125/6	1433	451	645	337	539	600	294	88	280	320	326	320	43	612
PML(S/H)	125/7	1533	451	745	337	539	700	294	88	280	320	326	320	43	659
PML(S/H)	125/8	1633	451	845	337	539	800	294	88	280	320	326	320	43	706
PML(S/H)	125/9	1733	451	945	337	539	900	294	88	280	320	326	320	43	753
PML(S/H)	125/10	1833	451	1045	337	539	1000	294	88	280	320	326	320	43	800

Foot dimensions Dimensions des pieds Dimensioni dei piedi							
I	L	M	N	O	P	Q	R
[mm]							
30	100	29,5	570	460	145	24	35

Shaft projection Saillie d'arbre Sporgenza d'albero						
a	b	c	d	e	f	g
[mm]						
45	48,5	14	9	100	110	125

Type Type Tipo	Flanges Brides Flange			
	(k) DNa [mm]	(l) PN [bar]	(r) DNm [mm]	(s) PN [bar]
PML	150	25	125	40
PMLS	150	25	125	63
PMLH	150	40	125	100

Plugs Bouchons Tappi		
J	K	W
G3/4	G1/2	G1/4

Selection - dimensions and weights for base mounted electric pumps  
 Sélection - dimensions et poids des électropompes sur socle  
 Selezione - dimensioni e pesi elettropompe su base

COUPLINGS WITH STANDARDIZED ENCLOSED ELECTRIC MOTORS / ACCOUPLEMENTS AVEC MOTEURS ÉLECTRIQUES FERMÉS NORMALISÉS /  
 ACCOPIAMENTI CON MOTORI ELETTRICI CHIUSI NORMALIZZATI

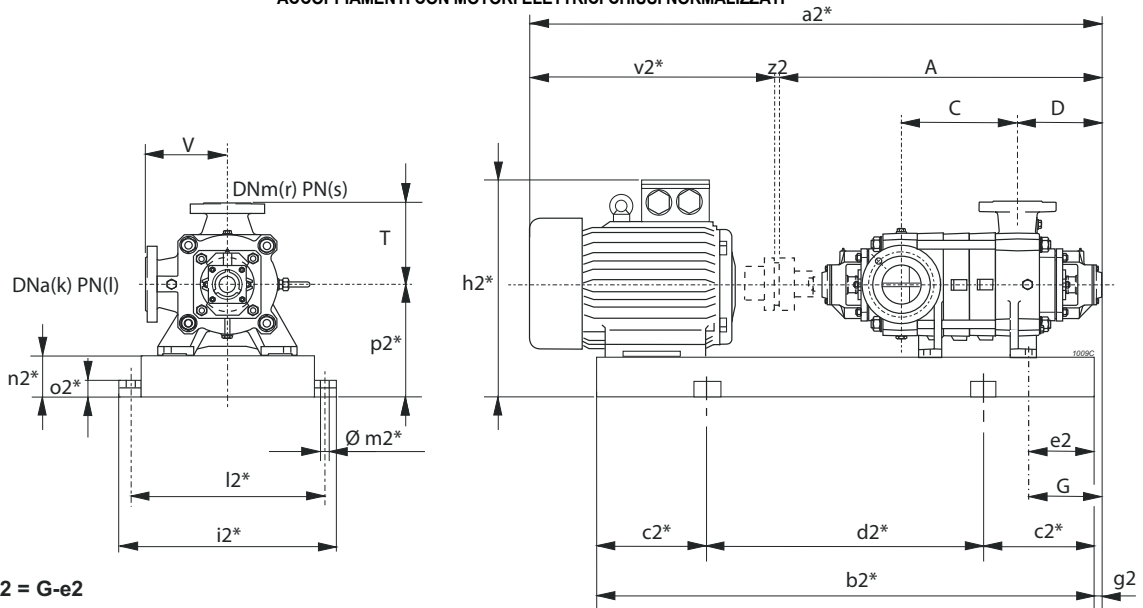

\* Valori indicativi in funzione della marca di motore utilizzato  
 Indicatives values according to the type of motor installed

Pump Pompe Pompa		Motor Moteur Motore		BGAM	A	C	D	G	T	V	a2*	b2*	c2*	d2*	e2	h2*	i2*	k	l	l2*	m2*	n2*	o2*	p2*	r	s	v2*	z2	Weight Poids Peso	
Series Série Serie	Type Type Tipo	[kW]	Size Taille Grand.	Type Type Tipo	[mm]																									[kg]
PML(S/H)	125/2	75	○	280S	802/HR	1033	245	337	294	320	320	2037	1568	250	1068	60	815	700	150	(1)	650	20	140	42	420	125	(2)	1000	4	1101
PML(S/H)	/2	90	○	280M	801/HR	1033	245	337	294	320	320	2088	1619	250	1119	60	815	700	150	(1)	650	20	140	42	420	125	(2)	1051	4	1230
PML(S/H)	/2	110	○	315S	800/IR	1033	245	337	294	320	320	2218	1695	300	1095	90	1030	780	150	(1)	730	22	160	50	475	125	(2)	1181	4	1543
PML(S/H)	/2	132	○	315M	335/IR	1033	245	337	294	320	320	2328	1805	300	1205	90	1030	780	150	(1)	730	22	160	50	475	125	(2)	1291	4	1619
PML(S/H)	/2	160	○	315L	335/IR	1033	245	337	294	320	320	2328	1805	300	1205	90	1030	780	150	(1)	730	22	160	50	475	125	(2)	1291	4	1697
PML(S/H)	/2	200	○	315L	336/IE4/LR	1033	245	337	294	320	320	2418	1895	300	1295	198	1030	780	150	(1)	730	22	160	50	475	125	(2)	1381	4	1831
PML(S/H)	125/3	110	○	315S	805/IR	1133	345	337	294	320	320	2318	1795	300	1195	90	1030	780	150	(1)	730	22	160	50	475	125	(2)	1181	4	1594
PML(S/H)	/3	132	○	315M	804/IR	1133	345	337	294	320	320	2428	1854	300	1254	90	1030	780	150	(1)	730	22	160	50	475	125	(2)	1291	4	1668
PML(S/H)	/3	160	○	315L	338/LR	1133	345	337	294	320	320	2428	1905	300	1305	90	1030	780	150	(1)	730	22	160	50	475	125	(2)	1291	4	1753
PML(S/H)	/3	200	○	315L	338/IE4/LR	1133	345	337	294	320	320	2518	1995	350	1295	198	1030	780	150	(1)	730	22	160	50	475	125	(2)	1381	4	1882
PML(S/H)	/3	250	○	355M	339/LR	1133	345	337	294	320	320	2663	2049	350	1349	110	1136	880	150	(1)	830	22	180	50	535	125	(2)	1526	4	2298
PML(S/H)	/3	280	○	355L	339/LR	1133	345	337	294	320	320	2663	2049	350	1349	110	1136	880	150	(1)	830	22	180	50	535	125	(2)	1526	4	2423
PML(S/H)	125/4	160	○	315L	807/IR	1233	445	337	294	320	320	2528	2005	350	1305	90	1030	780	150	(1)	730	22	160	50	475	125	(2)	1291	4	1799
PML(S/H)	/4	200	○	315L	806/IE4/LR	1233	445	337	294	320	320	2618	2095	350	1395	198	1030	780	150	(1)	730	22	160	50	475	125	(2)	1381	4	1933
PML(S/H)	/4	250	○	355M	340/LR	1233	445	337	294	320	320	2763	2079	350	1379	110	1136	880	150	(1)	830	22	180	50	535	125	(2)	1526	4	2349
PML(S/H)	/4	280	○	355L	340/MR	1233	445	337	294	320	320	2763	2149	350	1449	110	1136	880	150	(1)	830	22	180	50	535	125	(2)	1526	4	2478
PML(S/H)	/4	315	○	355L	340/MR	1233	445	337	294	320	320	2763	2149	350	1449	110	1136	880	150	(1)	830	22	180	50	535	125	(2)	1526	4	2478
PML(S/H)	/4	355	○	355L	340/MR	1233	445	337	294	320	320	2763	2149	350	1449	110	1136	880	150	(1)	830	22	180	50	535	125	(2)	1526	4	2468
PML(S/H)	125/5	200	○	315L	809/IE4/LR	1333	545	337	294	320	320	2718	2195	350	1495	198	1030	780	150	(1)	730	22	160	50	475	125	(2)	1381	4	1983
PML(S/H)	/5	250	○	355M	808/LR	1333	545	337	294	320	320	2863	2179	350	1479	110	1136	880	150	(1)	830	22	180	50	535	125	(2)	1526	4	2398
PML(S/H)	/5	280	○	355L	341/MR	1333	545	337	294	320	320	2863	2249	350	1549	110	1136	880	150	(1)	830	22	180	50	535	125	(2)	1526	4	2530
PML(S/H)	/5	315	○	355L	341/MR	1333	545	337	294	320	320	2863	2249	350	1549	110	1136	880	150	(1)	830	22	180	50	535	125	(2)	1526	4	2530
PML(S/H)	/5	355	○	355L	341/MR	1333	545	337	294	320	320	2863	2249	350	1549	110	1136	880	150	(1)	830	22	180	50	535	125	(2)	1526	4	2520
PML(H)	125/6	250	○	355M	4000/LR	1433	645	337	294	320	320	2963	2349	400	1549	110	1136	880	150	(1)	830	22	180	50	535	125	(2)	1526	4	2452
PML(H)	/6	280	○	355L	4000/LR	1433	645	337	294	320	320	2963	2349	400	1549	110	1136	880	150	(1)	830	22	180	50	535	125	(2)	1526	4	2577
PML(H)	/6	315	○	355L	4000/MR	1433	645	337	294	320	320	2963	2349	400	1549	110	1136	880	150	(1)	830	22	180	50	535	125	(2)	1526	4	2581
PML(H)	/6	355	○	355L	4000/MR	1433	645	337	294	320	320	2963	2349	400	1549	110	1136	880	150	(1)	830	22	180	50	535	125	(2)	1526	4	2571
PML(H)	125/7	250	○	355M	4001/LR	1533	745	337	294	320	320	3063	2449	400	1649	110	1136	880	150	(1)	830	22	180	50	535	125	(2)	1526	4	2504
PML(H)	/7	280	○	355L	4001/LR	1533	745	337	294	320	320	3063	2449	400	1649	110	1136	880	150	(1)	830	22	180	50	535	125	(2)	1526	4	2629
PML(H)	/7	315	○	355L	4001/MR	1533	745	337	294	320	320	3063	2449	400	1649	110	1136	880	150	(1)	830	22	180	50	535	125	(2)	1526	4	2633
PML(H)	/7	355	○	355L	4001/MR	1533	745	337	294	320	320	3063	2449	400	1649	110	1136	880	150	(1)	830	22	180	50	535	125	(2)	1526	4	2623
PML(H)	125/8	280	○	355L	4002/MR	1633	845	337	294	320	320	3163	2549	400	1749	110	1136	880	150	(1)	830	22	180	50	535	125	(2)	1526	4	2684
PML(H)	/8	315	○	355L	4002/MR	1633	845	337	294	320	320	3163	2549	400	1749	110	1136	880	150	(1)	830	22	180	50	535	125	(2)	1526	4	2684
PML(H)	/8	355	○	355L	4002/MR	1633	845	337	294	320	320	3163	2549	400	1749	110	1136	880	150	(1)	830	22	180	50	535	125	(2)	1526	4	2674

Contact the sales network for couplings exceeding 355 kW.

Pour des accouplements supérieurs à 355 kW, contacter notre réseau de vente.

Per accoppiamenti superiori a 355 kW, contattare la rete di vendita.

BGAM = Base and coupling  
 \* = Indicatives values according to the type of motor installed.

BGAM = Socle et accouplement  
 \* = Valeurs indicatives en fonction de la marque du moteur utilisé.

BGAM = Base giunto e coprigiunto  
 \* = Valori indicativi in funzione della marca di motore utilizzato.

○ Motor in IE4 efficiency class according to EU REGULATION 2019/1781. Available in other efficiency classes for non-EU markets.

○ Moteur en classe de rendement IE4 conformément au RÈGLEMENT UE2019/1781. Disponibili in différentes classes de rendement pour les marchés hors UE.

○ Motore in classe di efficienza IE4 in conformità al REGOLAMENTO UE2019/1781. Disponibili in altre classi di efficienza per mercati extra UE.

- (1) PML=25 bar PMLS=25 bar PMLH=40 bar
- (2) PML=40 bar PMLS=63 bar PMLH=100 bar

- (1) PML=25 bar PMLS=25 bar PMLH=40 bar
- (2) PML=40 bar PMLS=63 bar PMLH=100 bar

- (1) PML=25 bar PMLS=25 bar PMLH=40 bar
- (2) PML=40 bar PMLS=63 bar PMLH=100 bar

# PML 125

4P / 50Hz



Selection - dimensions and weights for base mounted electric pumps  
Sélection - dimensions et poids des électropompes sur socle  
Selezione - dimensioni e pesi elettropompe su base

COUPLINGS WITH STANDARDIZED ENCLOSED ELECTRIC MOTORS  
ACCOUPLLEMENTS AVEC MOTEURS ÉLECTRIQUES FERMÉS NORMALISÉS  
ACCOPIAMENTI CON MOTORI ELETTRICI CHIUSI NORMALIZZATI

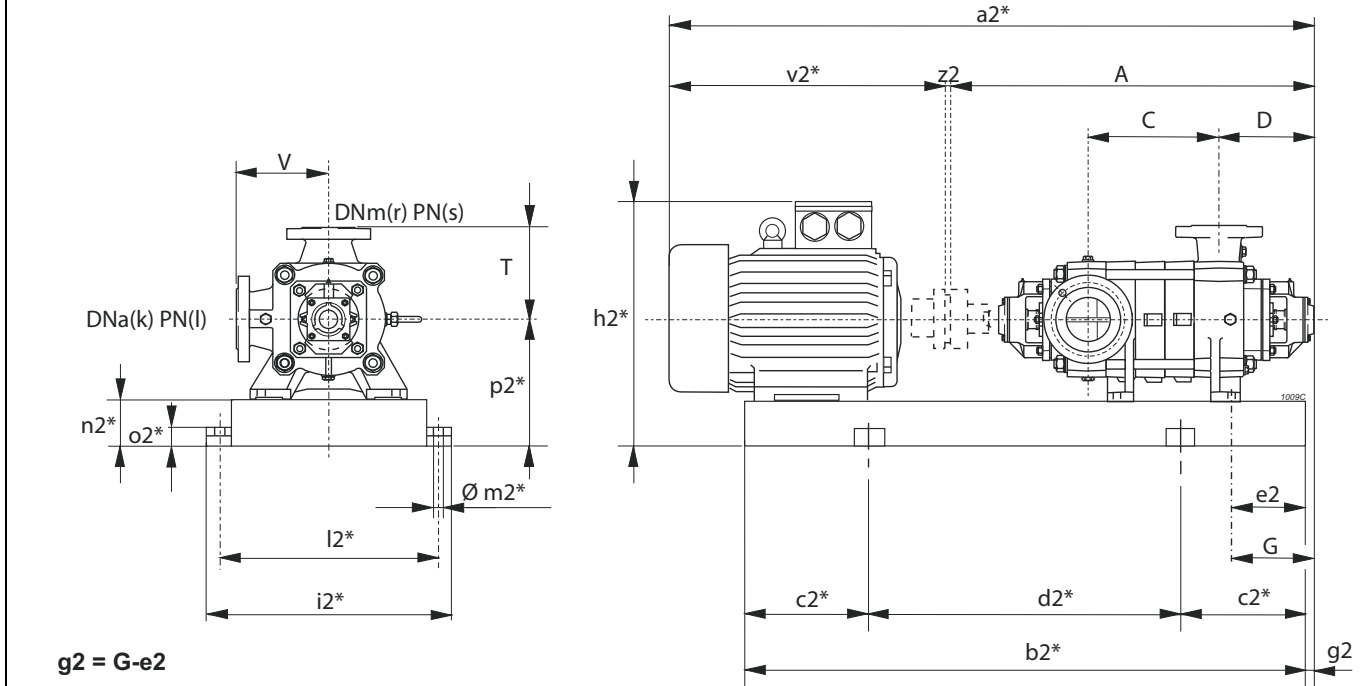

$g2 = G - e2$

\* Valori indicativi in funzione della marca di motore utilizzato  
Indicatives values according to the type of motor installed

Pump Pompe Pompa		Motor Moteur Motore		BGAM	A	C	D	G	T	V	a2*	b2*	c2*	d2*	e2	h2*	i2*	k	l	l2*	m2*	n2*	o2*	p2*	r	s	v2*	z2	Weight Poids Peso	
Series Série Serie	Type Type Tipo	[kW]	Size Taille Grand.	Type Type Tipo	[mm]																									[kg]
PML(S/H)	125/2	11	160M	870/EP	1033	245	337	294	320	320	1664	1296	200	896	60	671	700	150	(1)	650	20	140	42	420	125	(2)	627	4	671	
PML(S/H)	/2	15	160L	345/EP	1033	245	337	294	320	320	1664	1340	200	940	60	671	700	150	(1)	650	20	140	42	420	125	(2)	627	4	684	
PML(S/H)	/2	18,5	180M	346/FP	1033	245	337	294	320	320	1702	1350	250	850	60	690	700	150	(1)	650	20	140	42	420	125	(2)	665	4	765	
PML(S/H)	/2	22	180L	347/FP	1033	245	337	294	320	320	1742	1388	250	888	60	690	700	150	(1)	650	20	140	42	420	125	(2)	705	4	786	
PML(S/H)	125/3	15	160L	811/IR	1133	345	337	294	320	320	1764	1440	250	940	60	671	700	150	(1)	650	20	140	42	420	125	(2)	627	4	743	
PML(S/H)	/3	18,5	180M	850/FP	1133	345	337	294	320	320	1802	1450	250	950	60	690	700	150	(1)	650	20	140	42	420	125	(2)	665	4	815	
PML(S/H)	/3	22	180L	849/FP	1133	345	337	294	320	320	1842	1488	250	988	60	690	700	150	(1)	650	20	140	42	420	125	(2)	705	4	836	
PML(S/H)	/3	30	200L	349/GP	1133	345	337	294	320	320	1895	1523	250	1023	60	720	700	150	(1)	650	20	140	42	420	125	(2)	758	4	871	
PML(S/H)	/3	37	225S	350/HR	1133	345	337	294	320	320	1930	1554	250	1054	60	750	700	150	(1)	650	20	140	42	420	125	(2)	793	4	886	
PML(S/H)	125/4	18,5	180M	812/FP	1233	445	337	294	320	320	1902	1550	250	1050	60	690	700	150	(1)	650	20	140	42	420	125	(2)	665	4	865	
PML(S/H)	/4	22	180L	871/FP	1233	445	337	294	320	320	1942	1588	250	1088	60	690	700	150	(1)	650	20	140	42	420	125	(2)	705	4	886	
PML(S/H)	/4	30	200L	352/GP	1233	445	337	294	320	320	1995	1623	250	1123	60	720	700	150	(1)	650	20	140	42	420	125	(2)	758	4	921	
PML(S/H)	/4	37	225S	471/HR	1233	445	337	294	320	320	2030	1654	300	1054	60	750	700	150	(1)	650	20	140	42	420	125	(2)	793	4	937	
PML(S/H)	/4	45	225M	472/HR	1233	445	337	294	320	320	2055	1679	300	1079	60	750	700	150	(1)	650	20	140	42	420	125	(2)	818	4	979	
PML(S/H)	125/5	22	180L	814/FP	1333	545	337	294	320	320	2042	1688	300	1088	60	690	700	150	(1)	650	20	140	42	420	125	(2)	705	4	936	
PML(S/H)	/5	30	200L	851/GP	1333	545	337	294	320	320	2095	1723	300	1123	60	720	700	150	(1)	650	20	140	42	420	125	(2)	758	4	971	
PML(S/H)	/5	37	225S	813/HR	1333	545	337	294	320	320	2130	1754	300	1154	60	750	700	150	(1)	650	20	140	42	420	125	(2)	793	4	987	
PML(S/H)	/5	45	225M	475/HR	1333	545	337	294	320	320	2155	1779	300	1179	60	750	700	150	(1)	650	20	140	42	420	125	(2)	818	4	1029	
PML(S/H)	/5	55	250M	476/IR	1333	545	337	294	320	320	2217	1821	300	1221	60	795	700	150	(1)	650	20	140	42	420	125	(2)	880	4	1153	
PML(S/H)	125/6	30	200L	815/GP	1433	645	337	294	320	320	2195	1823	300	1223	60	720	700	150	(1)	650	20	140	42	420	125	(2)	758	4	1021	
PML(S/H)	/6	37	225S	852/HR	1433	645	337	294	320	320	2230	1854	300	1254	60	750	700	150	(1)	650	20	140	42	420	125	(2)	793	4	1037	
PML(S/H)	/6	45	225M	478/HR	1433	645	337	294	320	320	2255	1879	300	1279	60	750	700	150	(1)	650	20	140	42	420	125	(2)	818	4	1080	
PML(S/H)	/6	55	250M	479/IR	1433	645	337	294	320	320	2317	1921	300	1321	60	795	700	150	(1)	650	20	140	42	420	125	(2)	880	4	1203	
PML(S/H)	/6	75	280S	480/IR	1433	645	337	294	320	320	2450	1968	350	1268	60	815	700	150	(1)	650	20	140	42	420	125	(2)	1013	4	1344	
PML(S/H)	125/7	30	200L	817/GP	1533	745	337	294	320	320	2295	1923	300	1323	60	720	700	150	(1)	650	20	140	42	420	125	(2)	758	4	1072	
PML(S/H)	/7	37	225S	853/HR	1533	745	337	294	320	320	2330	1954	350	1254	60	750	700	150	(1)	650	20	140	42	420	125	(2)	793	4	1087	
PML(S/H)	/7	45	225M	816/HR	1533	745	337	294	320	320	2355	1979	350	1279	60	750	700	150	(1)	650	20	140	42	420	125	(2)	818	4	1130	
PML(S/H)	/7	55	250M	482/IR	1533	745	337	294	320	320	2417	2021	350	1321	60	795	700	150	(1)	650	20	140	42	420	125	(2)	880	4	1253	
PML(S/H)	/7	75	280S	483/IR	1533	745	337	294	320	320	2550	2068	350	1368	60	815	700	150	(1)	650	20	140	42	420	125	(2)	1013	4	1395	
PML(S/H)	/7	90	280M	484/LR	1533	745	337	294	320	320	2601	2119	350	1419	60	815	700	150	(1)	650	20	140	42	420	125	(2)	1064	4	1464	

BGAM = Base and coupling

\* = Indicatives values according to the type of motor installed.

○ Motor in IE4 efficiency class according to EU REGULATION 2019/1781. Available in other efficiency classes for non-EU markets.

- (1) PML=25 bar PMLS=25 bar PMLH=40 bar
- (2) PML=40 bar PMLS=63 bar PMLH=100 bar

BGAM = Socle et accouplement

\* = Valeurs indicatives en fonction de la marque du moteur utilisé.

○ Moteur en classe de rendement IE4 conformément au RÈGLEMENT UE2019/1781. Disponible en différentes classes de rendement pour les marchés hors UE.

- (1) PML=25 bar PMLS=25 bar PMLH=40 bar
- (2) PML=40 bar PMLS=63 bar PMLH=100 bar

BGAM = Base giunto e coprigiunto

\* = Valori indicativi in funzione della marca di motore utilizzato.

○ Motore in classe di efficienza IE4 in conformità al REGOLAMENTO UE2019/1781. Disponibili in altre classi di efficienza per mercati extra UE.

- (1) PML=25 bar PMLS=25 bar PMLH=40 bar
- (2) PML=40 bar PMLS=63 bar PMLH=100 bar

Selection - dimensions and weights for base mounted electric pumps  
 Sélection - dimensions et poids des électropompes sur socle  
 Selezione - dimensioni e pesi elettropompe su base

COUPLINGS WITH STANDARDIZED ENCLOSED ELECTRIC MOTORS  
 ACCOUPLEMENTS AVEC MOTEURS ÉLECTRIQUES FERMÉS NORMALISÉS  
 ACCOPIAMENTI CON MOTORI ELETTRICI CHIUSI NORMALIZZATI

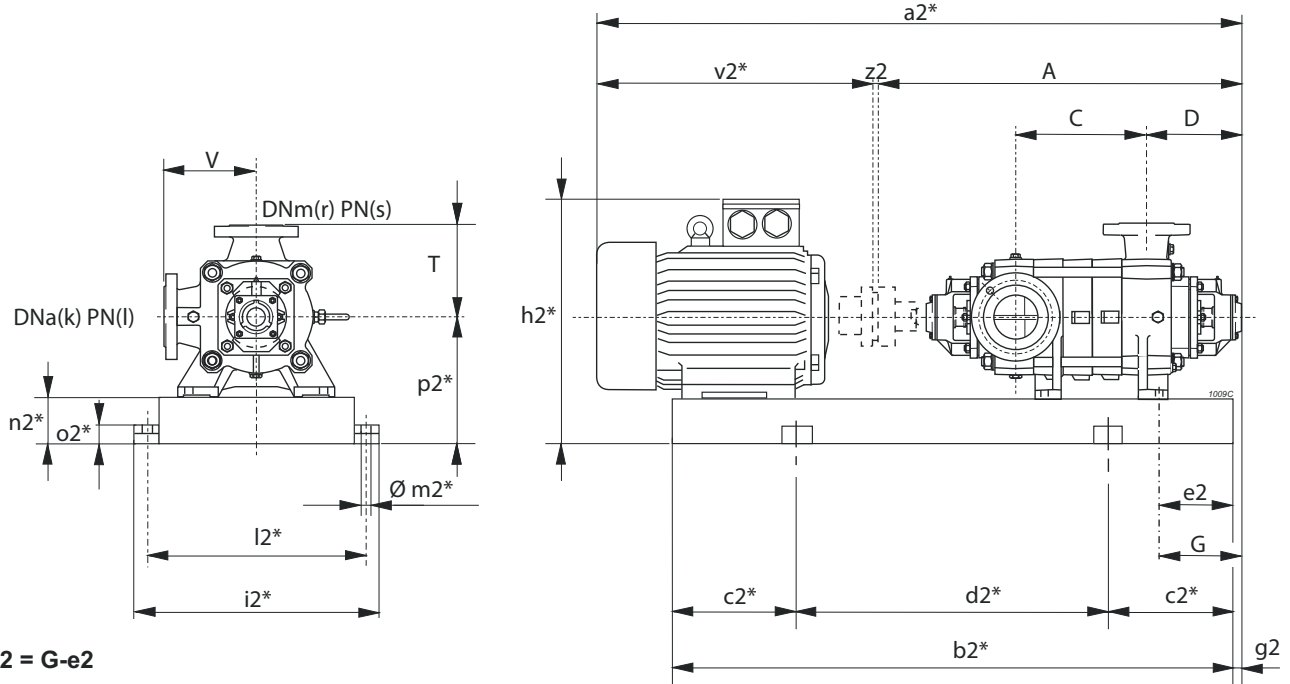

$g2 = G - e2$

\* Valori indicativi in funzione della marca di motore utilizzato  
 Indicatives values according to the type of motor installed

Pump Pompe Pompa		Motor Moteur Motore		BGAM	A	C	D	G	T	V	a2*	b2*	c2*	d2*	e2	h2*	i2*	k	l	l2*	m2*	n2*	o2*	p2*	r	s	v2*	z2	Weight Poids Peso	
Series Série Serie	Type Type Tipo	[kW]	Size Taille Grand.	Type Type Tipo	[mm]																									[kg]
PML(S/H)	125/8	37	225S	819/HR	1633	845	337	294	320	320	2430	2054	350	1354	60	750	700	150	(1)	650	20	140	42	420	125	(2)	793	4	1137	
PML(S/H)	/8	45	225M	872/HR	1633	845	337	294	320	320	2455	2079	350	1379	60	750	700	150	(1)	650	20	140	42	420	125	(2)	818	4	1180	
PML(S/H)	/8	55	250M	818/IR	1633	845	337	294	320	320	2517	2121	350	1421	60	795	700	150	(1)	650	20	140	42	420	125	(2)	880	4	1303	
PML(S/H)	/8	75	280S	486/IR	1633	845	337	294	320	320	2650	2168	350	1468	60	815	700	150	(1)	650	20	140	42	420	125	(2)	1013	4	1445	
PML(S/H)	/8	90	280M	487/LR	1633	845	337	294	320	320	2701	2219	350	1519	60	815	700	150	(1)	650	20	140	42	420	125	(2)	1064	4	1514	
PML(S/H)	125/9	37	225S	821/HR	1733	945	337	294	320	320	2530	2154	350	1454	60	750	700	150	(1)	650	20	140	42	420	125	(2)	793	4	1187	
PML(S/H)	/9	45	225M	854/HR	1733	945	337	294	320	320	2555	2179	350	1479	60	750	700	150	(1)	650	20	140	42	420	125	(2)	818	4	1230	
PML(S/H)	/9	55	250M	873/IR	1733	945	337	294	320	320	2617	2221	350	1521	60	795	700	150	(1)	650	20	140	42	420	125	(2)	880	4	1353	
PML(S/H)	/9	75	280S	490/IR	1733	945	337	294	320	320	2750	2268	400	1468	60	815	700	150	(1)	650	20	140	42	420	125	(2)	1013	4	1495	
PML(S/H)	/9	90	280M	491/LR	1733	945	337	294	320	320	2801	2319	400	1519	60	815	700	150	(1)	650	20	140	42	420	125	(2)	1064	4	1564	
PML(S/H)	/9	110	315S	492/LR	1733	945	337	294	320	320	2948	2425	400	1625	90	1030	780	150	(1)	730	22	160	50	475	125	(2)	1211	4	1899	
PML(S/H)	125/10	45	225M	822/HR	1833	1045	337	294	320	320	2655	2279	400	1479	60	750	700	150	(1)	650	20	140	42	420	125	(2)	818	4	1280	
PML(S/H)	/10	55	250M	874/IR	1833	1045	337	294	320	320	2717	2321	400	1521	60	795	700	150	(1)	650	20	140	42	420	125	(2)	880	4	1404	
PML(S/H)	/10	75	280S	494/IR	1833	1045	337	294	320	320	2850	2368	400	1568	60	815	700	150	(1)	650	20	140	42	420	125	(2)	1013	4	1545	
PML(S/H)	/10	90	280M	495/LR	1833	1045	337	294	320	320	2901	2419	400	1619	60	815	700	150	(1)	650	20	140	42	420	125	(2)	1064	4	1614	
PML(S/H)	/10	110	315S	496/LR	1833	1045	337	294	320	320	3048	2525	400	1725	90	1030	780	150	(1)	730	22	160	50	475	125	(2)	1211	4	1950	

BGAM = Base and coupling

\* = Indicatives values according to the type of motor installed.

○ Motor in IE4 efficiency class according to EU REGULATION 2019/1781. Available in other efficiency classes for non-EU markets.

- (1) PML=25 bar PMLS=25 bar PMLH=40 bar
- (2) PML=40 bar PMLS=63 bar PMLH=100 bar

BGAM = Socle et accouplement

\* = Valeurs indicatives en fonction de la marque du moteur utilisé.

○ Moteur en classe de rendement IE4 conformément au RÈGLEMENT UE2019/1781. Disponibilité en différentes classes de rendement pour les marchés hors UE.

- (1) PML=25 bar PMLS=25 bar PMLH=40 bar
- (2) PML=40 bar PMLS=63 bar PMLH=100 bar

BGAM = Base giunto e coprigiunto

\* = Valori indicativi in funzione della marca di motore utilizzato.

○ Motore in classe di efficienza IE4 in conformità al REGOLAMENTO UE2019/1781. Disponibili in altre classi di efficienza per mercati extra UE.

- (1) PML=25 bar PMLS=25 bar PMLH=40 bar
- (2) PML=40 bar PMLS=63 bar PMLH=100 bar