

SCC-2-250-450

1450 n [min⁻¹]

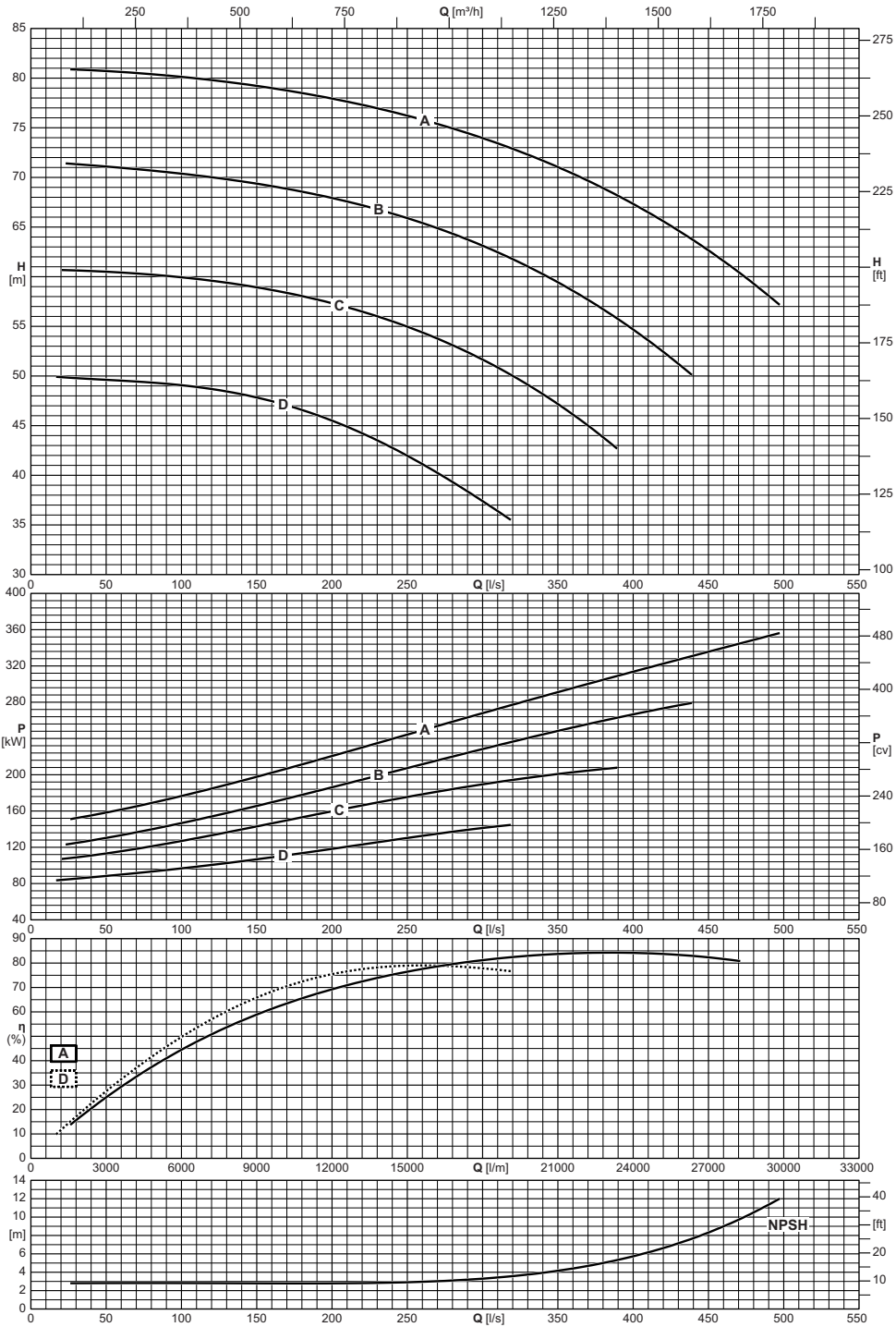

Operating data
Caracteristiques de fonctionnement
Caratteristiche di funzionamento



Electric pump type <i>Electropompe type</i> Elettropompa tipo	Impeller type <i>Roue type</i> Girante tipo	Capacity <i>Debit</i> Portata															
		[l/m]	1200	2400	3600	4800	6000	7500	9000	10500	12000	15000	18000	21000	24000	27000	29820
		[m³/h]	72	144	216	288	360	450	540	630	720	900	1080	1260	1440	1620	1789
	[l/s]	20	40	60	80	100	125	150	175	200	250	300	350	400	450	497	
		Total manometric head <i>Hauteur manometrique totale</i> Prevalenza manometrica totale															
SCC-2-250-450	A	[m]		80,8	80,6	80,4	80,1	79,7	79,2	78,6	77,9	76,2	73,9	71	67,3	62,6	57,2
SCC-2-250-450	B	[m]		71,2	71	70,7	70,4	69,9	69,4	68,7	67,9	65,9	63,1	59,4	54,7		
SCC-2-250-450	C	[m]		60,6	60,4	60,2	59,9	59,5	58,9	58,2	57,3	55	51,6	47,2			
SCC-2-250-450	D	[m]	49,9	49,7	49,5	49,3	49,1	48,6	47,8	46,8	45,5	42	37,4				
NPSH		[m]		2,8	2,8	2,8	2,8	2,8	2,8	2,8	2,8	2,9	3,3	4,2	5,8	8,3	12

Overall dimensions and weights
 Dimensions d'encombrement et poids
 Dimensioni di ingombro e pesi

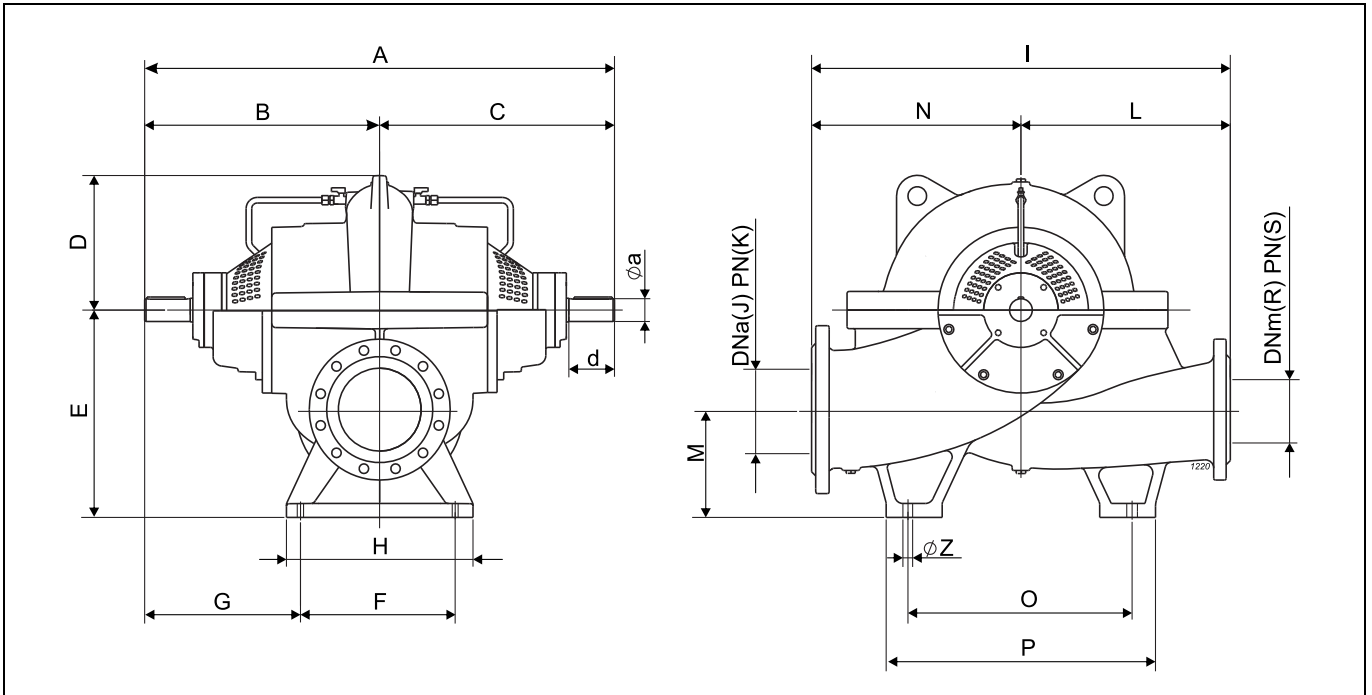

Type Type Tipo	Weight Poids Peso	A	B	C	D	E	F	G	H	I	J	K	L	M	N	O	P	R	S	Z	a	d
		[mm]																				
SCC-2-65-250	157	796	398	398	210	300	230	283	300	600	100	16	280	160	320	380	467	65	16	20	35	75
SCC-2-80-250	162	796	398	398	226	300	233	280	303	599	125	16	280	160	319	405	469	80	16	20	35	75
SCC-2-80-315	200	796	398	398	270	300	225	283,5	300	660	125	16	300	160	360	400	488	80	16	20	35	75
SCC-2-100-250	223	895	447,5	447,5	234	355	281	307	340	670	150	16	310	185	360	400	483	100	16	20	42	90
SCC-2-100-315	230	895	447,5	447,5	252	355	275	309	340	670	150	16	310	185	360	400	485	100	16	20	42	90
SCC-2-100-400	303	895	447,5	447,5	303	355	280	307,5	340	790	150	16	370	185	420	460	560	100	16	20	42	90
SCC-2-125-315	360	1052	526	526	284	400	320	366	380	790	200	16	370	200	420	460	540	125	16	22	55	110
SCC-2-125-350	402	1052	526	526	310	400	320	366	380	920	200	16	450	200	470	540	660	125	16	22	55	110
SCC-2-125-480	400	983	491,5	491,5	308	400	340	321,5	390	900	200	16	450	200	450	560	640	125	16	22	42	90
SCC-2-150-315	400	1052	526	526	319	400	320	366	380	870	200	16	400	200	470	540	643	150	16	22	55	110
SCC-2-150-460	430	1090	545	545	305	400	320	385	380	900	200	16	450	200	450	540	640	150	16	22	55	110
SCC-2-150-600	780	1284	642	642	437	560	320	482	420	1050	250	25	500	260	550	640	640	150	25	22	65	130
SCC-2-200-315	590	1284	642	642	337	500	360	462	420	950	250	16	450	260	500	540	643	200	16	22	65	130
SCC-2-200-430	630	1132	566	566	317	500	360	386	450	1000	250	16	500	260	500	540	650	200	16	24	55	110
SCC-2-200-500	690	1284	642	642	377	560	360	462	420	1050	250	16	500	260	550	620	724	200	16	22	65	130
SCC-2-250-350	680	1284	642	642	399	600	356	464	420	1100	300	16	500	300	600	620	724	250	16	30	65	130
SCC-2-250-450	780	1284	642	642	424	600	360	462	420	1100	300	16	500	300	600	620	720	250	16	23	65	130
SCC-2-250-600	1050	1440	720	720	441	600	405	517,5	485	1200	300	25	550	300	650	620	715	250	25	26	80	170
SCC-2-300-315	700	1284	642	642	400	630	348	468	420	1100	350	16	500	330,03	600	620	700	300	16	24	65	130
SCC-2-300-400	930	1328	664	664	365	630	420	454	520	1190	400	16	560	310	630	680	800	300	16	26	60	140
SCC-2-300-500	1500	1519	759,5	759,5	436	710	410	554,5	520	1450	400	16	750	360	700	700	809	300	16	26	80	170
SCC-2-300-700	1650	1731	865,5	865,5	489	710	410	660,5	520	1550	400	25	800	360	750	720	880	300	25	26,5	100	180
SCC-2-350-350	1120	1544	772	772	449	670	420	562	520	1250	400	16	550	320	700	720	804	350	16	26	75	140
SCC-2-350-400	1410	1545	772,5	772,5	502	800	500	522,5	600	1400	500	16	600	420	800	800	961	350	16	26	75	140
SCC-2-350-500	1435	1509	754,5	754,5	443	800	498	505,5	600	1400	500	16	600	400	800	740	910	350	16	26	80	170
SCC-2-350-700	2000	1731	865,5	865,5	534	850	498	616,5	600	1600	500	25	750	400	850	720	890	350	25	26	100	180

SCC-2

4P / 50Hz

caprari

Selection - dimensions and weights for base mounted electric pumps
Sélection - dimensions et poids des électropompes sur socle
 Selezione - dimensioni e pesi elettropompe su base

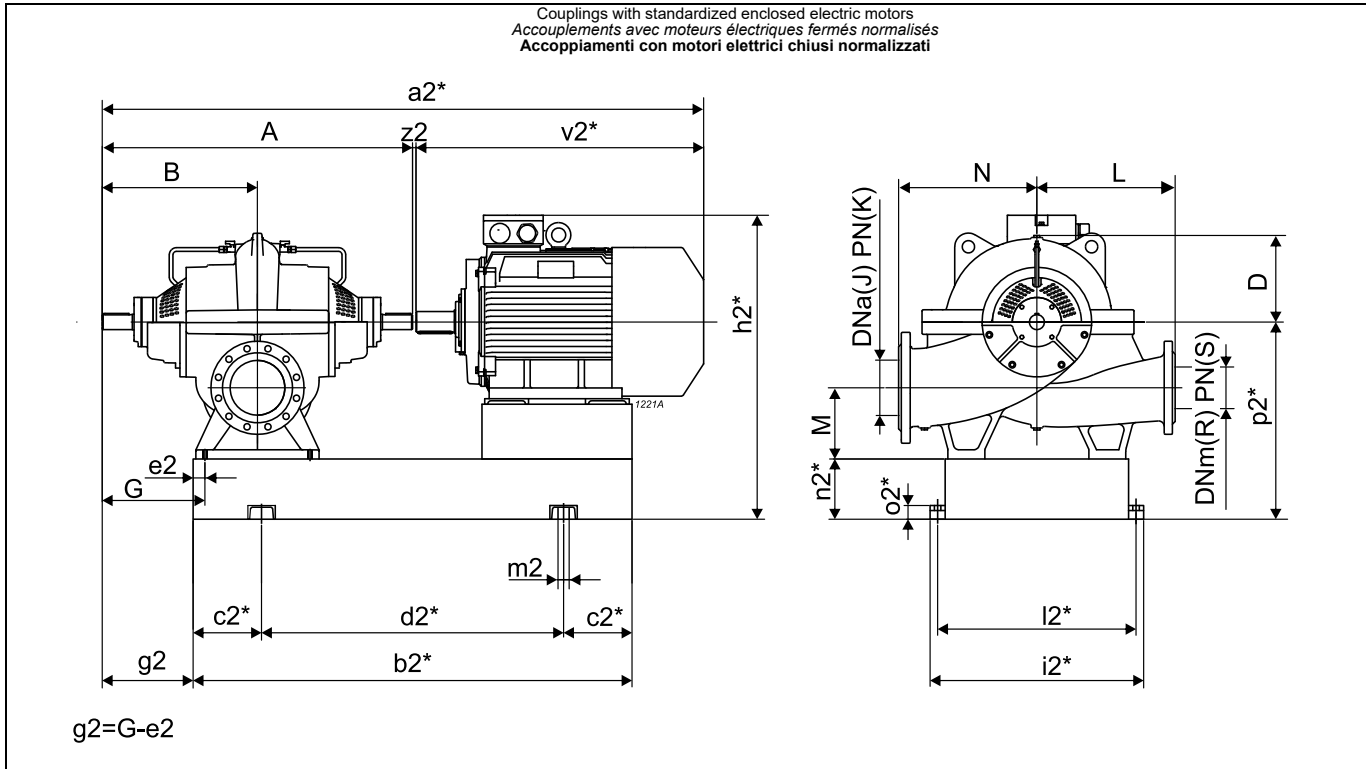

Pump Pompe Pompa	Motor Moteur Motore		Weight Poids Peso	BGAC2	A	B	D	G	J	K	L	M	N	R	S	a2*	b2*	c2*	d2*	e2	h2*	i2*	l2*	m2	n2*	o2*	p2*	v2*	z2		
	Type Type Tipo	[kW]			Size Taille Grand.	[kg]	[mm]																								
SCC-2-250-450	315	355L	2978	250-450-315/355	1284	642	424	462	300	16	500	300	600	250	16	2844	2080	350	1380	50	1421	860	810	22	220	50	820	1556	4		
SCC-2-250-450	355	355L	2993	250-450-315/355	1284	642	424	462	300	16	500	300	600	250	16	2844	2080	350	1380	50	1421	860	810	22	220	50	820	1556	4		
SCC-2-250-600	355	355L	3270	250-600-355	1440	720	441	517,5	300	25	550	300	650	250	25	3000	2191	350	1491	55	1421	860	810	22	220	50	820	1556	4		
SCC-2-300-315	37	225S	1349	300-315-37	1284	642	400	468	350	16	500	330	600	300	16	2081	1579	250	1079	50	1180	850	800	22	220	50	850	793	4		
SCC-2-300-315	45	225M	1394	300-315-45	1284	642	400	468	350	16	500	330	600	300	16	2106	1604	250	1104	50	1180	850	800	22	220	50	850	818	4		
SCC-2-300-315	55	250M	1504	300-315-55	1284	642	400	468	350	16	500	330	600	300	16	2168	1661	300	1061	50	1225	850	800	22	220	50	850	880	4		
SCC-2-300-315	75	280S	1628	300-315-75	1284	642	400	468	350	16	500	330	600	300	16	2301	1672	300	1072	50	1245	850	800	22	220	50	850	1013	4		
SCC-2-300-315	90	280M	1697	300-315-90	1284	642	400	468	350	16	500	330	600	300	16	2352	1723	300	1123	50	1245	850	800	22	220	50	850	1064	4		
SCC-2-300-400	132	315M	2364	300-400-132	1328	664	365	454	400	16	560	310	630	300	16	2653	1912	300	1312	60	1405	930	880	22	220	50	850	1321	4		
SCC-2-300-400	160	315L	2472	300-400-160	1328	664	365	454	400	16	560	310	630	300	16	2653	1963	350	1263	60	1405	930	880	22	220	50	850	1321	4		
SCC-2-300-400	200	315L	2595	300-400-200	1328	664	365	454	400	16	560	310	630	300	16	2743	2031	350	1341	60	1405	930	880	22	220	50	850	1411	4		
SCC-2-300-400	250	355M	2953	300-400-250	1328	664	365	454	400	16	560	310	630	300	16	2888	2083	350	1383	60	1451	930	880	22	220	50	850	1556	4		
SCC-2-300-500	250	355M	3560	300-500-250	1519	759,5	436	554,5	400	16	750	360	700	300	16	3079	2168	350	1468	70	1531	940	890	22	220	50	930	1556	4		
SCC-2-300-500	315	355L	3758	300-500-315/355	1519	759,5	436	554,5	400	16	750	360	700	300	16	3079	2238	350	1538	70	1531	940	890	22	220	50	930	1556	4		
SCC-2-300-500	355	355L	3773	300-500-315/355	1519	759,5	436	554,5	400	16	750	360	700	300	16	3079	2238	350	1538	70	1531	940	890	22	220	50	930	1556	4		
SCC-2-350-350	90	280M	2179	350-350-90	1544	772	449	562	400	16	550	320	700	350	16	2612	1935	300	1335	70	1285	930	880	22	220	50	890	1064	4		
SCC-2-350-350	110	315S	2348	350-350-110	1544	772	449	562	400	16	550	320	700	350	16	2759	1948	300	1348	70	1445	930	880	22	220	50	890	1211	4		
SCC-2-350-350	132	315M	2459	350-350-132	1544	772	449	562	400	16	550	320	700	350	16	2869	1999	350	1299	70	1445	930	880	22	220	50	890	1321	4		
SCC-2-350-350	160	315L	2622	350-350-160	1544	772	449	562	400	16	550	320	700	350	16	2869	2050	350	1350	70	1445	930	880	22	220	50	890	1321	4		
SCC-2-350-350	200	315L	2687	350-350-200	1544	772	449	562	400	16	550	320	700	350	16	2959	2138	350	1438	70	1445	930	880	22	220	50	890	1411	4		
SCC-2-350-400	160	315L	3187	350-400-160	1545	772,5	502	522,5	500	16	600	420	800	350	16	2870	2080	350	1380	70	1575	1110	1060	22	220	50	1020	1321	4		
SCC-2-350-400	200	315L	3329	350-400-200	1545	772,5	502	522,5	500	16	600	420	800	350	16	2960	2170	350	1470	70	1575	1110	1060	22	220	50	1020	1411	4		
SCC-2-350-400	250	355M	3654	350-400-250	1545	772,5	502	522,5	500	16	600	420	800	350	16	3105	2200	350	1500	70	1621	1110	1060	22	220	50	1020	1556	4		
SCC-2-350-400	315	355L	3850	350-400-315/355	1545	772,5	502	522,5	500	16	600	420	800	350	16	3105	2270	350	1570	70	1621	1110	1060	22	220	50	1020	1556	4		
SCC-2-350-400	355	355L	3865	350-400-315/355	1545	772,5	502	522,5	500	16	600	420	800	350	16	3105	2270	350	1570	70	1621	1110	1060	22	220	50	1020	1556	4		
SCC-2-350-500	355	355L	3867	350-500-355	1509	754,5	443	505,5	500	16	600	400	800	350	16	3069	2253	350	1553	70	1621	1050	1000	22	220	50	1020	1556	4		

BGAC2 = Base and coupling

* = Indicatives values according to the type of motor installed.

o Motor in IE4 efficiency class according to EU REGULATION 2019/1781. Available in other efficiency classes for non-EU markets.

BGAC2 = Socle et accouplement

* = Valeurs indicatives en fonction de la marque du moteur utilisé.

o Moteur en classe de rendement IE4 conformément au RÈGLEMENT UE2019/1781. Disponibilit  en diff rentes classes de rendement pour les march s hors UE.

BGAC2 = Base e giunto

* = Valori indicativi in funzione della marca di motore utilizzato.

o Motore in classe di efficienza IE4 in conformit  al REGOLAMENTO UE2019/1781. Disponibili in altre classi di efficienza per mercati extra UE.