

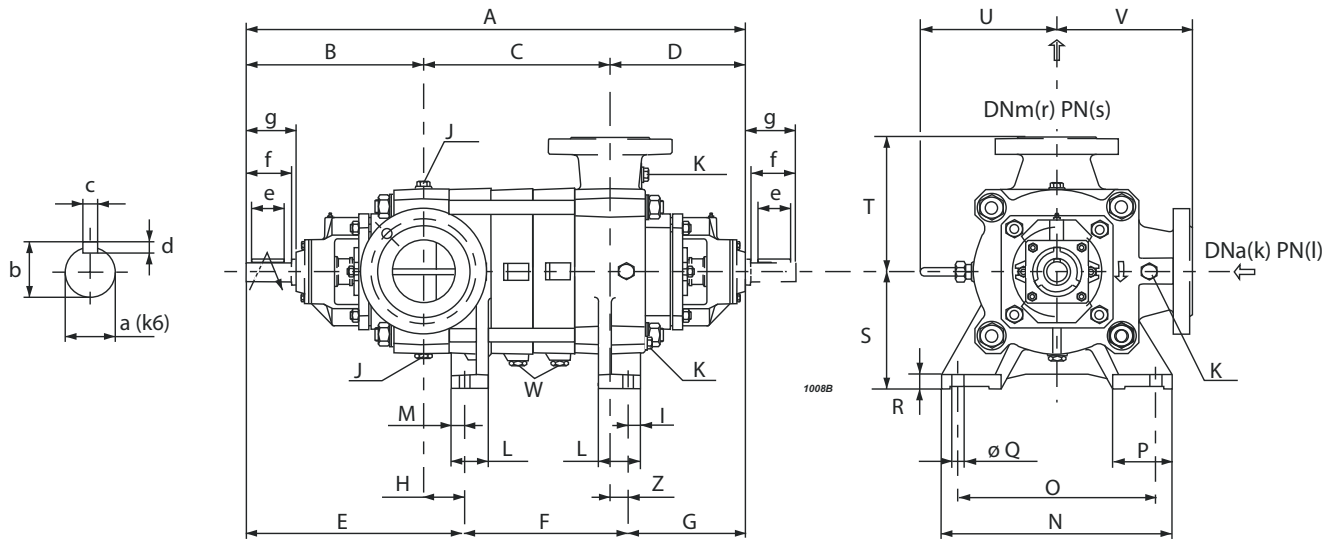

Overall dimensions and weights  
 Dimensions d'encombrement et poids  
 Dimensioni di ingombro e pesi



Series Série Serie	Type Type Tipo	A	B	C	D	E	F	G	H	S	T	U	V	Z	Weight Poids Peso
		[mm]													[kg]
PM(S)	100/2	828	365	170	293	419	149	260	53,5	225	270	275	270	33	219
PM(S)	100/3	903	365	245	293	419	224	260	53,5	225	270	273	270	33	244
PM(S/H)	100/4	978	365	320	293	419	299	260	53,5	225	270	273	270	33	270
PM(S/H)	100/5	1053	365	395	293	419	374	260	53,5	225	270	273	270	33	295
PM(S/H)	100/6	1128	365	470	293	419	449	260	53,5	225	270	273	270	33	320
PM(S/H)	100/7	1203	365	545	293	419	524	260	53,5	225	270	273	270	33	345
PM(S/H)	100/8	1278	365	620	293	419	599	260	53,5	225	270	273	270	33	370
PM(S/H)	100/9	1353	365	695	293	419	674	260	53,5	225	270	273	270	33	395
PM(S/H)	100/10	1428	365	770	293	419	749	260	53,5	225	270	273	270	33	420
PM(S/H)	100/11	1503	365	845	293	419	824	260	53,5	225	270	273	270	33	446

Foot dimensions Dimensions des pieds Dimensioni dei piedi							
I	L	M	N	O	P	Q	R
[mm]							
32	85	32	460	400	117	24	30

Shaft projection Saille d'arbre Sporgenza d'albero							
a	b	c	d	e	f	g	
[mm]							
35	38	10	8	70	90	104	

Type Type Tipo	Flanges Brides Flange			
	(k) DNa	(l) PN	(r) DNm	(s) PN
	[mm]	[bar]	[mm]	[bar]
PM	125	25	100	40
PMS	125	25	100	63
PMH	125	40	100	100

Plugs Bouchons Tappi		
J	K	W
G1/2	G1/2	G1/4

Selection - dimensions and weights for base mounted electric pumps  
 Sélection - dimensions et poids des électropompes sur socle  
 Selezione - dimensioni e pesi elettropompe su base

COUPLINGS WITH STANDARDIZED ENCLOSED ELECTRIC MOTORS  
 ACCOUPLEMENTS AVEC MOTEURS ÉLECTRIQUES FERMÉS NORMALISÉS  
 ACCOPPIAMENTI CON MOTORI ELETTRICI CHIUSI NORMALIZZATI

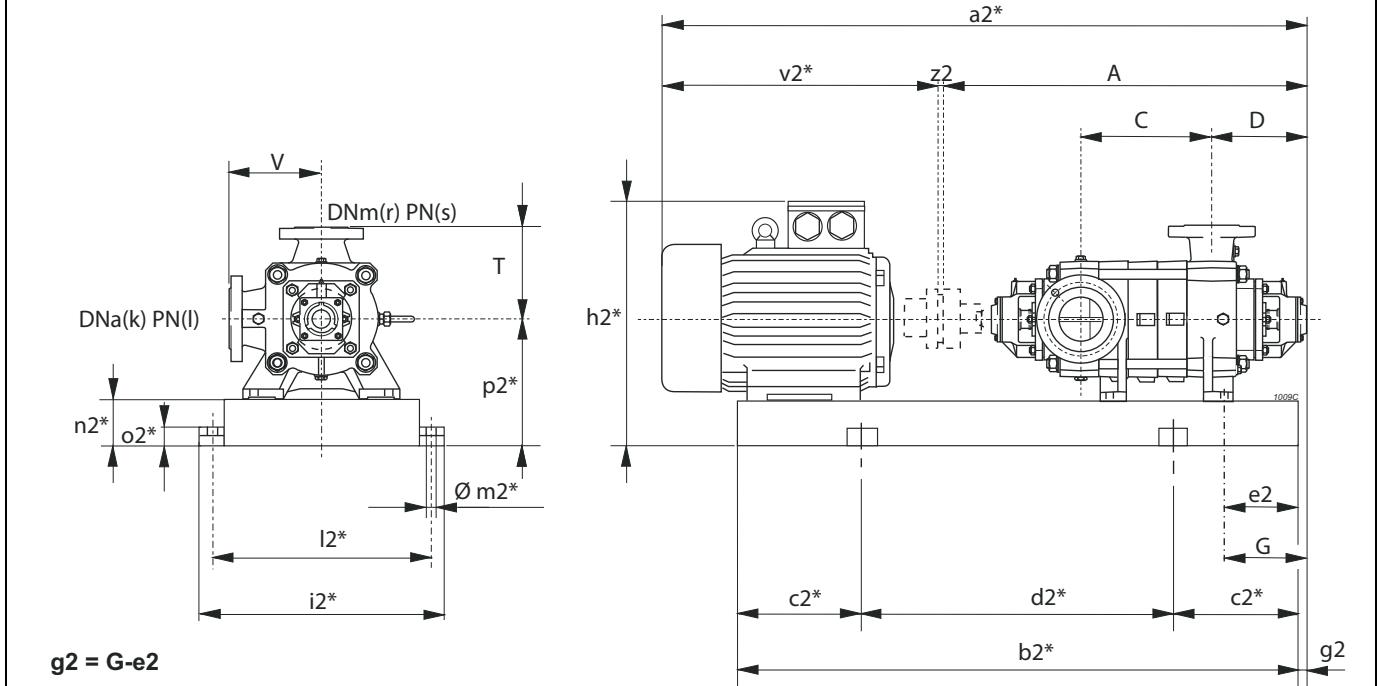

$g2 = G - e2$

\* Valori indicativi in funzione della marca di motore utilizzato  
 Indicatives values according to the type of motor installed

Pump Pompe Pompa	Motor Moteur Motore	BGAM	A	C	D	G	T	V	a2*	b2*	c2*	d2*	e2	h2*	i2*	k	l	l2*	m2*	n2*	o2*	p2*	r	s	v2*	z2	Weight Poids Peso		
Series Série Serie	Type Type Tipo	Size Taille Grand.	Type Type Tipo	[mm]																						[kg]			
PM(S)	100/2	45	225M	775/FN	827,5	169,5	293	260	270	270	1606,5	1268	200	868	50	675	590	125	(1)	540	20	120	42	345	100	(2)	775	4	609
PM(S)	/2	55	250M	776/GQ	827,5	169,5	293	260	270	270	1701,5	1360	250	860	70	745	635	125	(1)	585	20	120	42	370	100	(2)	870	4	708
PM(S)	/2	75	280S	777/HQ	827,5	169,5	293	260	270	270	1831,5	1407	250	907	70	815	695	125	(1)	645	20	140	42	420	100	(2)	1000	4	895
PM(S)	/2	90	280M	778/HQ	827,5	169,5	293	260	270	270	1882,5	1458	250	958	70	815	695	125	(1)	645	20	140	42	420	100	(2)	1051	4	1023
PM(S)	100/3	75	280S	779/HQ	902,5	244,5	293	260	270	270	1906,5	1482	250	982	70	815	695	125	(1)	645	20	140	42	420	100	(2)	1000	4	922
PM(S)	/3	90	280M	780/HQ	902,5	244,5	293	260	270	270	1957,5	1533	250	1033	70	815	695	125	(1)	645	20	140	42	420	100	(2)	1051	4	1051
PM(S)	/3	110	315S	781/IQ	902,5	244,5	293	260	270	270	2087,5	1609	250	1109	100	1030	780	125	(1)	730	22	160	50	475	100	(2)	1181	4	1409
PM(S)	/3	132	315M	782/IQ	902,5	244,5	293	260	270	270	2197,5	1668	300	1068	100	1030	780	125	(1)	730	22	160	50	475	100	(2)	1291	4	1484
PM(S/H)	100/4	90	280M	783/HQ	977,5	319,5	293	260	270	270	2032,5	1608	250	1108	70	815	695	125	(1)	645	20	140	42	420	100	(2)	1051	4	1079
PM(S/H)	/4	110	315S	784/IQ	977,5	319,5	293	260	270	270	2162,5	1684	300	1084	100	1030	780	125	(1)	730	22	160	50	475	100	(2)	1181	4	1438
PM(S/H)	/4	132	315M	785/IQ	977,5	319,5	293	260	270	270	2272,5	1743	300	1143	100	1030	780	125	(1)	730	22	160	50	475	100	(2)	1291	4	1512
PM(S/H)	/4	160	315L	785/IQ	977,5	319,5	293	260	270	270	2272,5	1743	300	1143	100	1030	780	125	(1)	730	22	160	50	475	100	(2)	1291	4	1590
PM(S/H)	/4	200	315L	786/IE4/LQ	977,5	319,5	293	260	270	270	2362,5	1884	300	1284	198	1030	780	125	(1)	730	22	160	50	475	100	(2)	1381	4	1709
PM(S/H)	100/5	110	315S	787/IQ	1052,5	394,5	293	260	270	270	2237,5	1759	300	1159	100	1030	780	125	(1)	730	22	160	50	475	100	(2)	1181	4	1466
PM(S/H)	/5	132	315M	788/IQ	1052,5	394,5	293	260	270	270	2347,5	1818	300	1218	100	1030	780	125	(1)	730	22	160	50	475	100	(2)	1291	4	1540
PM(S/H)	/5	160	315L	788/IQ	1052,5	394,5	293	260	270	270	2347,5	1818	300	1218	100	1030	780	125	(1)	730	22	160	50	475	100	(2)	1291	4	1618
PM(S/H)	/5	200	315L	789/IE4/LQ	1052,5	394,5	293	260	270	270	2437,5	1959	350	1259	198	1030	780	125	(1)	730	22	160	50	475	100	(2)	1381	4	1736
PM(S/H)	/5	250	355M	790/LQ	1052,5	394,5	293	260	270	270	2582,5	1923	300	1323	100	1136	880	125	(1)	830	22	180	50	535	100	(2)	1526	4	2128
PM(S/H)	100/6	132	315M	791/IQ	1127,5	469,5	293	260	270	270	2422,5	1893	300	1293	100	1030	780	125	(1)	730	22	160	50	475	100	(2)	1291	4	1568
PM(S/H)	/6	160	315L	791/IQ	1127,5	469,5	293	260	270	270	2422,5	1893	300	1293	100	1030	780	125	(1)	730	22	160	50	475	100	(2)	1291	4	1646
PM(S/H)	/6	200	315L	792/IE4/LQ	1127,5	469,5	293	260	270	270	2512,5	2034	350	1334	198	1030	780	125	(1)	730	22	160	50	475	100	(2)	1381	4	1764
PM(S/H)	/6	250	355M	793/LQ	1127,5	469,5	293	260	270	270	2657,5	2068	350	1368	100	1136	880	125	(1)	830	22	180	50	535	100	(2)	1526	4	2160
PM(S/H)	/6	280	355L	793/LQ	1127,5	469,5	293	260	270	270	2657,5	2068	350	1368	100	1136	880	125	(1)	830	22	180	50	535	100	(2)	1526	4	2285
PM(S/H)	/6	315	355L	793/MQ	1127,5	469,5	293	260	270	270	2657,5	2068	350	1368	100	1136	880	125	(1)	830	22	180	50	535	100	(2)	1526	4	2289
PM(S/H)	100/7	160	315L	798/IQ	1202,5	544,5	293	260	270	270	2497,5	2019	350	1319	100	1030	780	125	(1)	730	22	160	50	475	100	(2)	1291	4	1676
PM(S/H)	/7	200	315L	794/IE4/LQ	1202,5	544,5	293	260	270	270	2587,5	2109	350	1409	198	1030	780	125	(1)	730	22	160	50	475	100	(2)	1381	4	1791
PM(S/H)	/7	250	355M	795/LQ	1202,5	544,5	293	260	270	270	2732,5	2143	350	1443	100	1136	880	125	(1)	830	22	180	50	535	100	(2)	1526	4	2188
PM(S/H)	/7	280	355L	795/LQ	1202,5	544,5	293	260	270	270	2732,5	2143	350	1443	100	1136	880	125	(1)	830	22	180	50	535	100	(2)	1526	4	2313
PM(S/H)	/7	315	355L	795/MQ	1202,5	544,5	293	260	270	270	2732,5	2143	350	1443	100	1136	880	125	(1)	830	22	180	50	535	100	(2)	1526	4	2317

BGAM = Base and coupling

\* = Indicatives values according to the type of motor installed.

○ Motor in IE4 efficiency class according to EU REGULATION 2019/1781. Available in other efficiency classes for non-EU markets.

- (1) PM=25 bar PMS=25 bar PMH=40 bar
- (2) PM=40 bar PMS=63 bar PMH=100 bar

BGAM = Socle et accouplement

\* = Valeurs indicatives en fonction de la marque du moteur utilisé.

○ Moteur en classe de rendement IE4 conformément au RÈGLEMENT UE2019/1781. Disponibilités en différentes classes de rendement pour les marchés hors UE.

- (1) PM=25 bar PMS=25 bar PMH=40 bar
- (2) PM=40 bar PMS=63 bar PMH=100 bar

BGAM = Base giunto e coprigiunto

\* = Valori indicativi in funzione della marca di motore utilizzato.

○ Motore in classe di efficienza IE4 in conformità al REGOLAMENTO UE2019/1781. Disponibili in altre classi di efficienza per mercati extra UE.

- (1) PM=25 bar PMS=25 bar PMH=40 bar
- (2) PM=40 bar PMS=63 bar PMH=100 bar

Selection - dimensions and weights for base mounted electric pumps  
 Sélection - dimensions et poids des électropompes sur socle  
 Selezione - dimensioni e pesi elettropompe su base

COUPLINGS WITH STANDARDIZED ENCLOSED ELECTRIC MOTORS  
 ACCOUPLEMENTS AVEC MOTEURS ÉLECTRIQUES FERMÉS NORMALISÉS  
 ACCOPPIAMENTI CON MOTORI ELETTRICI CHIUSI NORMALIZZATI

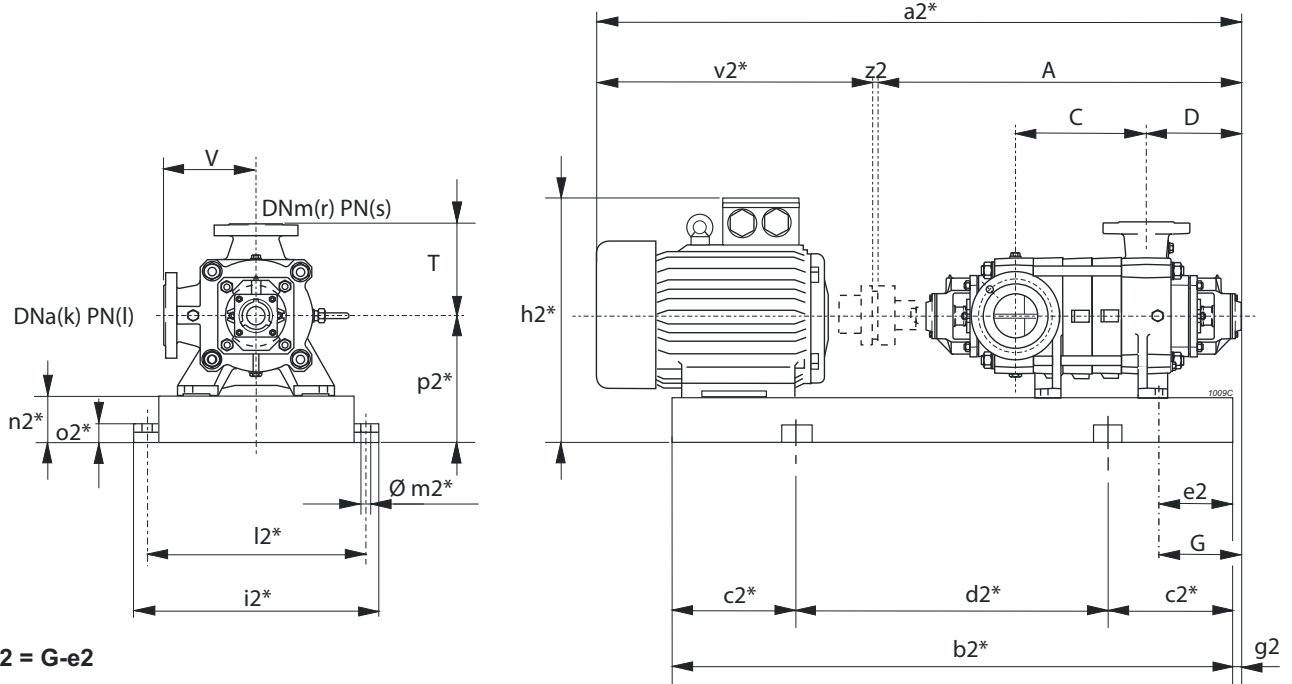

$g2 = G - e2$

\* Valori indicativi in funzione della marca di motore utilizzato  
 Indicatives values according to the type of motor installed

Pump Pompe Pompa		Motor Moteur Motore		BGAM	A	C	D	G	T	V	a2*	b2*	c2*	d2*	e2	h2*	i2*	k	l	l2*	m2*	n2*	o2*	p2*	r	s	v2*	z2	Weight Poids Peso
Series Série Serie	Type Type Tipo	[kW]	Size Taille Grand.	Type Type Tipo	[mm]																								[kg]
PM(S/H)	100/8	160	315L	799/IQ	1277,5	619,5	293	260	270	270	2572,5	2094	350	1394	100	1030	780	125	(1)	730	22	160	50	475	100	(2)	1291	4	1704
PM(S/H)	/8	200	315L	796/IE4/LQ	1277,5	619,5	293	260	270	270	2662,5	2184	350	1484	198	1030	780	125	(1)	730	22	160	50	475	100	(2)	1381	4	1819
PM(S/H)	/8	250	355M	797/LQ	1277,5	619,5	293	260	270	270	2807,5	2218	350	1518	100	1136	880	125	(1)	830	22	180	50	535	100	(2)	1526	4	2216
PM(S/H)	/8	280	355L	797/LQ	1277,5	619,5	293	260	270	270	2807,5	2218	350	1518	100	1136	880	125	(1)	830	22	180	50	535	100	(2)	1526	4	2341
PM(S/H)	/8	315	355L	797/MQ	1277,5	619,5	293	260	270	270	2807,5	2218	350	1518	100	1136	880	125	(1)	830	22	180	50	535	100	(2)	1526	4	2345
PM(S/H)	/8	355	355L	797/MQ	1277,5	619,5	293	260	270	270	2807,5	2218	350	1518	100	1136	880	125	(1)	830	22	180	50	535	100	(2)	1526	4	2335
PM(H)	100/9	200	315L	1255/IE4/LQ	1352,5	694,5	293	260	270	270	2737,5	2259	400	1459	198	1030	780	125	(1)	730	22	160	50	475	100	(2)	1381	4	1847
PM(H)	/9	250	355M	1256/LQ	1352,5	694,5	293	260	270	270	2882,5	2293	400	1493	100	1136	880	125	(1)	830	22	180	50	535	100	(2)	1526	4	2245
PM(H)	/9	280	355L	1256/LQ	1352,5	694,5	293	260	270	270	2882,5	2293	400	1493	100	1136	880	125	(1)	830	22	180	50	535	100	(2)	1526	4	2370
PM(H)	/9	315	355L	1256/MQ	1352,5	694,5	293	260	270	270	2882,5	2293	400	1493	100	1136	880	125	(1)	830	22	180	50	535	100	(2)	1526	4	2374
PM(H)	/9	355	355L	1256/MQ	1352,5	694,5	293	260	270	270	2882,5	2293	400	1493	100	1136	880	125	(1)	830	22	180	50	535	100	(2)	1526	4	2364
PM(H)	100/10	200	315L	1257/IE4/LQ	1427,5	769,5	293	260	270	270	2812,5	2334	400	1534	198	1030	780	125	(1)	730	22	160	50	475	100	(2)	1381	4	1875
PM(H)	/10	250	355M	1258/MQ	1427,5	769,5	293	260	270	270	2957,5	2368	400	1568	100	1136	880	125	(1)	830	22	180	50	535	100	(2)	1526	4	2277
PM(H)	/10	280	355L	1258/MQ	1427,5	769,5	293	260	270	270	2957,5	2368	400	1568	100	1136	880	125	(1)	830	22	180	50	535	100	(2)	1526	4	2402
PM(H)	/10	315	355L	1258/MQ	1427,5	769,5	293	260	270	270	2957,5	2368	400	1568	100	1136	880	125	(1)	830	22	180	50	535	100	(2)	1526	4	2402
PM(H)	/10	355	355L	1258/MQ	1427,5	769,5	293	260	270	270	2957,5	2368	400	1568	100	1136	880	125	(1)	830	22	180	50	535	100	(2)	1526	4	2392
PM(H)	100/11	250	355M	1259/LQ	1502,5	844,5	293	260	270	270	3032,5	2443	400	1643	100	1136	880	125	(1)	830	22	180	50	535	100	(2)	1526	4	2303
PM(H)	/11	280	355L	1259/LQ	1502,5	844,5	293	260	270	270	3032,5	2443	400	1643	100	1136	880	125	(1)	830	22	180	50	535	100	(2)	1526	4	2428
PM(H)	/11	315	355L	1259/MQ	1502,5	844,5	293	260	270	270	3032,5	2443	400	1643	100	1136	880	125	(1)	830	22	180	50	535	100	(2)	1526	4	2432
PM(H)	/11	355	355L	1259/MQ	1502,5	844,5	293	260	270	270	3032,5	2443	400	1643	100	1136	880	125	(1)	830	22	180	50	535	100	(2)	1526	4	2422

BGAM = Base and coupling

\* = Indicatives values according to the type of motor installed.

○ Motor in IE4 efficiency class according to EU REGULATION 2019/1781. Available in other efficiency classes for non-EU markets.

- (1) PM=25 bar PMS=25 bar PMH=40 bar
- (2) PM=40 bar PMS=63 bar PMH=100 bar

BGAM = Socle et accouplement

\* = Valeurs indicatives en fonction de la marque du moteur utilisé.

○ Moteur en classe de rendement IE4 conformément au RÈGLEMENT UE2019/1781. Disponibilités en différentes classes de rendement pour les marchés hors UE.

- (1) PM=25 bar PMS=25 bar PMH=40 bar
- (2) PM=40 bar PMS=63 bar PMH=100 bar

BGAM = Base giunto e coprigiunto

\* = Valori indicativi in funzione della marca di motore utilizzato.

○ Motore in classe di efficienza IE4 in conformità al REGOLAMENTO UE2019/1781. Disponibili in altre classi di efficienza per mercati extra UE.

- (1) PM=25 bar PMS=25 bar PMH=40 bar
- (2) PM=40 bar PMS=63 bar PMH=100 bar

# PM 100

4P / 50Hz



Selection - dimensions and weights for base mounted electric pumps  
 Sélection - dimensions et poids des électropompes sur socle  
 Selezione - dimensioni e pesi elettropompe su base

COUPLINGS WITH STANDARDIZED ENCLOSED ELECTRIC MOTORS  
 ACCOUPLEMENTS AVEC MOTEURS ÉLECTRIQUES FERMÉS NORMALISÉS  
 ACCOPPIAMENTI CON MOTORI ELETTRICI CHIUSI NORMALIZZATI

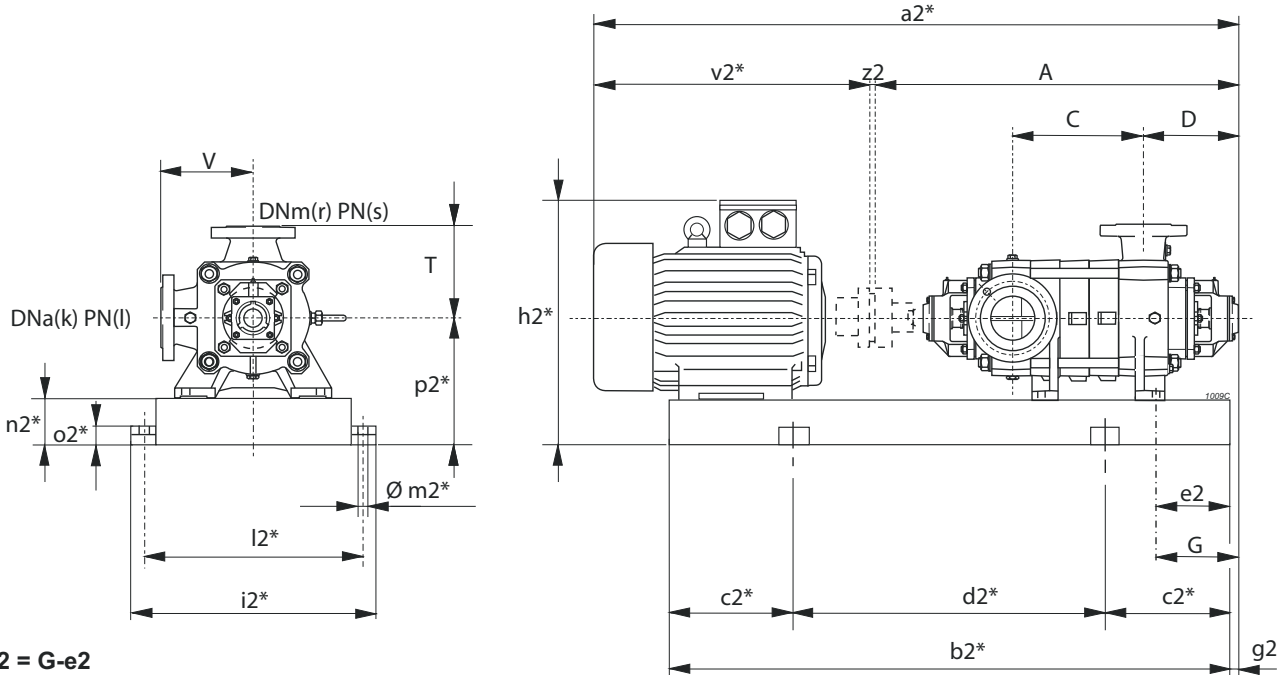

\* Valori indicativi in funzione della marca di motore utilizzato  
 Indicatives values according to the type of motor installed

Pump Pompe Pompa		Motor Moteur Motore		BGAM	A	C	D	G	T	V	a2*	b2*	c2*	d2*	e2	h2*	i2*	k	l	l2*	m2*	n2*	o2*	p2*	r	s	v2*	z2	Weight Poids Peso			
Series Série Serie	Type Type Tipo	[kW]	Size Taille Grand.	Type Type Tipo	[mm]																											[kg]
PM(S)	100/2	5,5	132S	730/CN	827,5	169,5	293	260	270	270	1286,5	971	150	671	50	537	590	125	(1)	540	20	120	42	345	100	(2)	455	4	324			
PM(S)	/2	7,5	132M	731/DN	827,5	169,5	293	260	270	270	1321,5	1009	150	709	50	537	590	125	(1)	540	20	120	42	345	100	(2)	490	4	335			
PM(S)	/2	11	160M	732/EN	827,5	169,5	293	260	270	270	1458,5	1115	200	715	50	596	590	125	(1)	540	20	120	42	345	100	(2)	627	4	433			
PM(S)	100/3	7,5	132M	733/DN	902,5	244,5	293	260	270	270	1396,5	1084	200	684	50	537	590	125	(1)	540	20	120	42	345	100	(2)	490	4	362			
PM(S)	/3	11	160M	734/EN	902,5	244,5	293	260	270	270	1533,5	1190	200	790	50	596	590	125	(1)	540	20	120	42	345	100	(2)	627	4	460			
PM(S)	/3	15	160L	735/EN	902,5	244,5	293	260	270	270	1533,5	1234	200	834	50	596	590	125	(1)	540	20	120	42	345	100	(2)	627	4	473			
PM(S)	/3	18,5	180M	736/FN	902,5	244,5	293	260	270	270	1571,5	1244	200	844	50	615	590	125	(1)	540	20	120	42	345	100	(2)	665	4	500			
PM(S/H)	100/4	11	160M	737/EN	977,5	319,5	293	260	270	270	1608,5	1265	200	865	50	596	590	125	(1)	540	20	120	42	345	100	(2)	627	4	488			
PM(S/H)	/4	15	160L	738/EN	977,5	319,5	293	260	270	270	1608,5	1309	200	909	50	596	590	125	(1)	540	20	120	42	345	100	(2)	627	4	501			
PM(S/H)	/4	18,5	180M	739/FN	977,5	319,5	293	260	270	270	1646,5	1319	200	919	50	615	590	125	(1)	540	20	120	42	345	100	(2)	665	4	528			
PM(S/H)	/4	22	180L	740/FN	977,5	319,5	293	260	270	270	1686,5	1357	250	857	50	615	590	125	(1)	540	20	120	42	345	100	(2)	705	4	549			
PM(S/H)	100/5	15	160L	741/EN	1052,5	394,5	293	260	270	270	1683,5	1384	250	884	50	596	590	125	(1)	540	20	120	42	345	100	(2)	627	4	528			
PM(S/H)	/5	18,5	180M	742/FN	1052,5	394,5	293	260	270	270	1721,5	1394	250	894	50	615	590	125	(1)	540	20	120	42	345	100	(2)	665	4	555			
PM(S/H)	/5	22	180L	743/FN	1052,5	394,5	293	260	270	270	1761,5	1432	250	932	50	615	590	125	(1)	540	20	120	42	345	100	(2)	705	4	576			
PM(S/H)	/5	30	200L	744/GN	1052,5	394,5	293	260	270	270	1814,5	1467	250	967	50	645	590	125	(1)	540	20	120	42	345	100	(2)	758	4	639			
PM(S/H)	100/6	15	160L	745/EN	1127,5	469,5	293	260	270	270	1758,5	1459	250	959	50	596	590	125	(1)	540	20	120	42	345	100	(2)	627	4	555			
PM(S/H)	/6	18,5	180M	746/FN	1127,5	469,5	293	260	270	270	1796,5	1469	250	969	50	615	590	125	(1)	540	20	120	42	345	100	(2)	665	4	582			
PM(S/H)	/6	22	180L	747/FN	1127,5	469,5	293	260	270	270	1836,5	1507	250	1007	50	615	590	125	(1)	540	20	120	42	345	100	(2)	705	4	603			
PM(S/H)	/6	30	200L	748/GN	1127,5	469,5	293	260	270	270	1889,5	1542	250	1042	50	645	590	125	(1)	540	20	120	42	345	100	(2)	758	4	666			
PM(S/H)	/6	37	225S	749/HQ	1127,5	469,5	293	260	270	270	1924,5	1573	250	1073	50	675	590	125	(1)	540	20	120	42	345	100	(2)	793	4	711			
PM(S/H)	100/7	18,5	180M	750/FN	1202,5	544,5	293	260	270	270	1871,5	1544	250	1044	50	615	590	125	(1)	540	20	120	42	345	100	(2)	665	4	609			
PM(S/H)	/7	22	180L	751/FN	1202,5	544,5	293	260	270	270	1911,5	1582	250	1082	50	615	590	125	(1)	540	20	120	42	345	100	(2)	705	4	630			
PM(S/H)	/7	30	200L	752/GN	1202,5	544,5	293	260	270	270	1964,5	1617	250	1117	50	645	590	125	(1)	540	20	120	42	345	100	(2)	758	4	693			
PM(S/H)	/7	37	225S	753/HQ	1202,5	544,5	293	260	270	270	1999,5	1648	250	1148	50	675	590	125	(1)	540	20	120	42	345	100	(2)	793	4	738			
PM(S/H)	100/8	22	180L	754/FN	1277,5	619,5	293	260	270	270	1986,5	1657	300	1057	50	615	590	125	(1)	540	20	120	42	345	100	(2)	705	4	657			
PM(S/H)	/8	30	200L	755/GN	1277,5	619,5	293	260	270	270	2039,5	1692	300	1092	50	645	590	125	(1)	540	20	120	42	345	100	(2)	758	4	720			
PM(S/H)	/8	37	225S	756/HQ	1277,5	619,5	293	260	270	270	2074,5	1723	300	1123	50	675	590	125	(1)	540	20	120	42	345	100	(2)	793	4	765			
PM(S/H)	/8	45	225M	757/HQ	1277,5	619,5	293	260	270	270	2099,5	1748	300	1148	50	675	590	125	(1)	540	20	120	42	345	100	(2)	818	4	807			
PM(S/H)	100/9	30	200L	758/GN	1352,5	694,5	293	260	270	270	2114,5	1767	300	1167	50	645	590	125	(1)	540	20	120	42	345	100	(2)	758	4	747			

BGAM = Base and coupling

\* = Indicatives values according to the type of motor installed.

○ Motor in IE4 efficiency class according to EU REGULATION 2019/1781. Available in other efficiency classes for non-EU markets.

- (1) PM=25 bar PMS=25 bar PMH=40 bar
- (2) PM=40 bar PMS=63 bar PMH=100 bar

BGAM = Socle et accouplement

\* = Valeurs indicatives en fonction de la marque du moteur utilisé.

○ Moteur en classe de rendement IE4 conformément au RÈGLEMENT UE2019/1781. Disponibilité en différentes classes de rendement pour les marchés hors UE.

- (1) PM=25 bar PMS=25 bar PMH=40 bar
- (2) PM=40 bar PMS=63 bar PMH=100 bar

BGAM = Base giunto e coprigiunto

\* = Valori indicativi in funzione della marca di motore utilizzato.

○ Motore in classe di efficienza IE4 in conformità al REGOLAMENTO UE2019/1781. Disponibili in altre classi di efficienza per mercati extra UE.

- (1) PM=25 bar PMS=25 bar PMH=40 bar
- (2) PM=40 bar PMS=63 bar PMH=100 bar

Selection - dimensions and weights for base mounted electric pumps  
 Sélection - dimensions et poids des électropompes sur socle  
 Selezione - dimensioni e pesi elettropompe su base

COUPLINGS WITH STANDARDIZED ENCLOSED ELECTRIC MOTORS  
 ACCOUPLEMENTS AVEC MOTEURS ÉLECTRIQUES FERMÉS NORMALISÉS  
 ACCOPPIAMENTI CON MOTORI ELETTRICI CHIUSI NORMALIZZATI

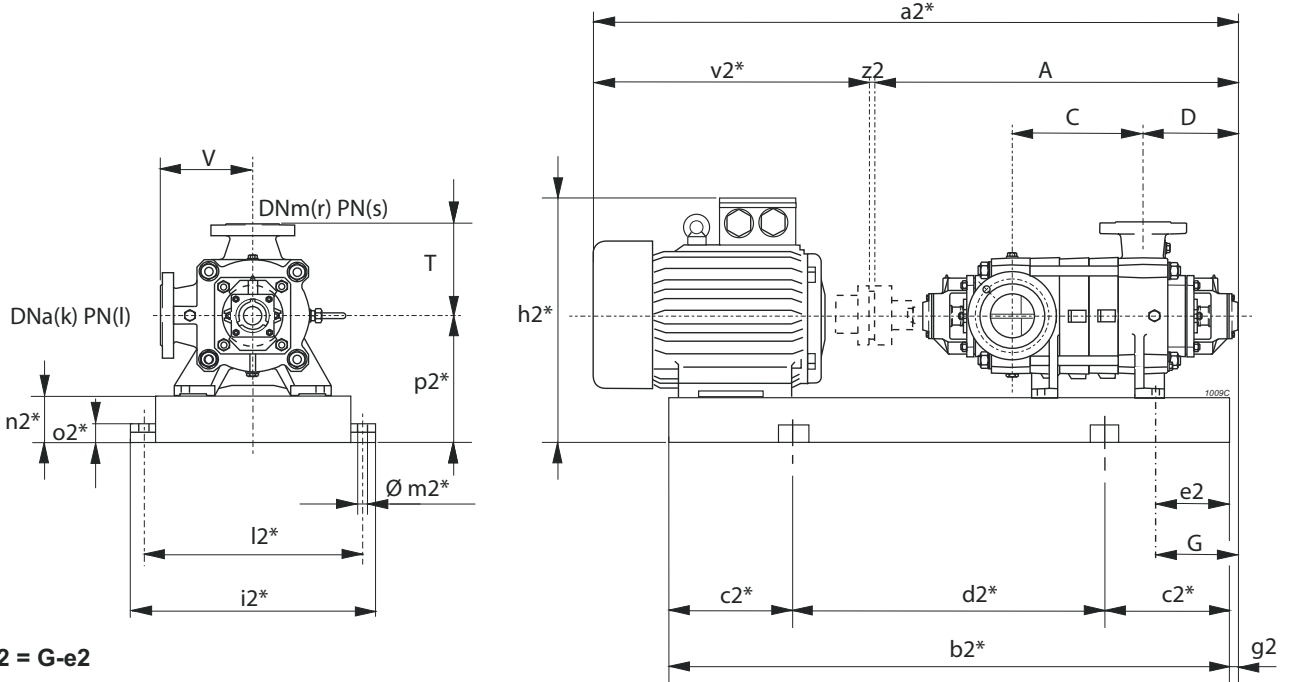

\* Valori indicativi in funzione della marca di motore utilizzato  
 Indicatives values according to the type of motor installed

Pump Pompe Pompa		Motor Moteur Motore		BGAM	A	C	D	G	T	V	a2*	b2*	c2*	d2*	e2	h2*	i2*	k	l	l2*	m2*	n2*	o2*	p2*	r	s	v2*	z2	Weight Poids Peso
Series Série Serie	Type Type Tipo	[kW]	Size Taille Grand.	Type Type Tipo	[mm]																								[kg]
PM(S/H)	/9	37	225S	759/HQ	1352,5	694,5	293	260	270	270	2149,5	1798	300	1198	50	675	590	125	(1)	540	20	120	42	345	100	(2)	793	4	792
PM(S/H)	/9	45	225M	760/HQ	1352,5	694,5	293	260	270	270	2174,5	1823	300	1223	50	675	590	125	(1)	540	20	120	42	345	100	(2)	818	4	834
PM(S/H)	/9	55	250M	761/IQ	1352,5	694,5	293	260	270	270	2236,5	1885	300	1285	70	745	635	125	(1)	585	20	120	42	370	100	(2)	880	4	963
PM(S/H)	100/10	30	200L	762/GN	1427,5	769,5	293	260	270	270	2189,5	1842	300	1242	50	645	590	125	(1)	540	20	120	42	345	100	(2)	758	4	774
PM(S/H)	/10	37	225S	763/HQ	1427,5	769,5	293	260	270	270	2224,5	1873	300	1273	50	675	590	125	(1)	540	20	120	42	345	100	(2)	793	4	819
PM(S/H)	/10	45	225M	764/HQ	1427,5	769,5	293	260	270	270	2249,5	1898	300	1298	50	675	590	125	(1)	540	20	120	42	345	100	(2)	818	4	861
PM(S/H)	/10	55	250M	765/IQ	1427,5	769,5	293	260	270	270	2311,5	1960	350	1260	70	745	635	125	(1)	585	20	120	42	370	100	(2)	880	4	990
PM(S/H)	100/11	30	200L	766/GN	1502,5	844,5	293	260	270	270	2264,5	1917	300	1317	50	645	590	125	(1)	540	20	120	42	345	100	(2)	758	4	802
PM(S/H)	/11	37	225S	767/HQ	1502,5	844,5	293	260	270	270	2299,5	1948	300	1348	50	675	590	125	(1)	540	20	120	42	345	100	(2)	793	4	847
PM(S/H)	/11	45	225M	768/HQ	1502,5	844,5	293	260	270	270	2324,5	1973	350	1273	50	675	590	125	(1)	540	20	120	42	345	100	(2)	818	4	889
PM(S/H)	/11	55	250M	769/IQ	1502,5	844,5	293	260	270	270	2386,5	2035	350	1335	70	745	635	125	(1)	585	20	120	42	370	100	(2)	880	4	1018
PM(S/H)	/11	75	280S	770/IQ	1502,5	844,5	293	260	270	270	2519,5	2082	350	1382	70	815	695	125	(1)	645	20	140	42	420	100	(2)	1013	4	1186

BGAM = Base and coupling

\* = Indicatives values according to the type of motor installed.

○ Motor in IE4 efficiency class according to EU REGULATION 2019/1781. Available in other efficiency classes for non-EU markets.

- (1) PM=25 bar PMS=25 bar PMH=40 bar  
 (2) PM=40 bar PMS=63 bar PMH=100 bar

BGAM = Socle et accouplement

\* = Valeurs indicatives en fonction de la marque du moteur utilisé.

○ Moteur en classe de rendement IE4 conformément au RÈGLEMENT UE2019/1781. Disponibilité en différentes classes de rendement pour les marchés hors UE.

- (1) PM=25 bar PMS=25 bar PMH=40 bar  
 (2) PM=40 bar PMS=63 bar PMH=100 bar

BGAM = Base giunto e coprigiunto

\* = Valori indicativi in funzione della marca di motore utilizzato.

○ Motore in classe di efficienza IE4 in conformità al REGOLAMENTO UE2019/1781. Disponibili in altre classi di efficienza per mercati extra UE.

- (1) PM=25 bar PMS=25 bar PMH=40 bar  
 (2) PM=40 bar PMS=63 bar PMH=100 bar

# PM 100H

2P / 50Hz

# caprari

Selection - dimensions and weights for base mounted electric pumps  
 Sélection - dimensions et poids des électropompes sur socle  
 Selezione - dimensioni e pesi elettropompe su base

COUPLINGS WITH STANDARDIZED ENCLOSED ELECTRIC MOTORS  
 ACCOUPLEMENTS AVEC MOTEURS ÉLECTRIQUES FERMÉS NORMALISÉS  
 ACCOPIAMENTI CON MOTORI ELETTRICI CHIUSI NORMALIZZATI

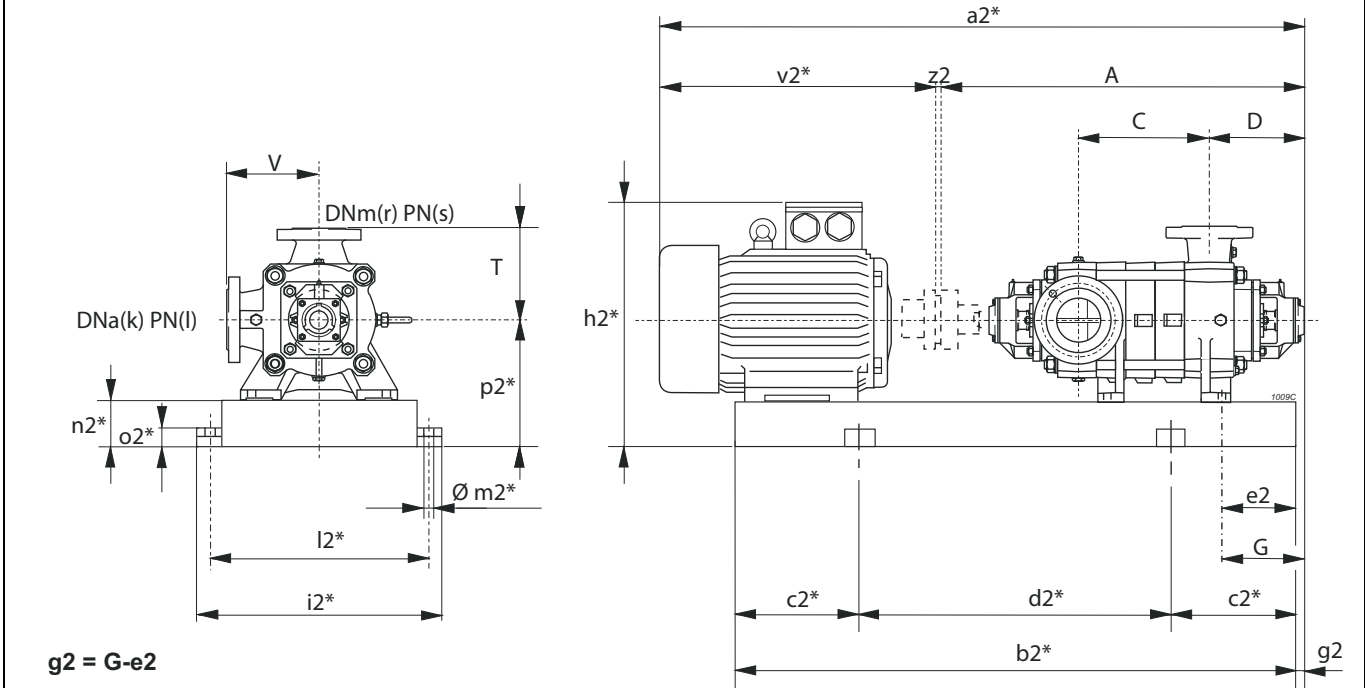

\* Valori indicativi in funzione della marca di motore utilizzato  
 Indicatives values according to the type of motor installed

Pump Pompe Pompa	Motor Moteur Motore	BGAM	A	C	D	G	T	V	a2*	b2*	c2*	d2*	e2	h2*	i2*	k	l	l2*	m2*	n2*	o2*	p2*	r	s	v2*	z2	Weight Poids Peso		
Serie Série Serie	Type Type Tipo	[kW]	Size Taille Grand.	Type Type Tipo	[mm]																				[kg]				
PM(S)	100H/2	45	225M	775/FN	827,5	169,5	293	260	270	270	1606,5	1268	200	868	50	675	590	125	(1)	540	20	120	42	345	100	(2)	775	4	609
PM(S)	/2	55	250M	776/GQ	827,5	169,5	293	260	270	270	1701,5	1360	250	860	70	745	635	125	(1)	585	20	120	42	370	100	(2)	870	4	708
PM(S)	/2	75	280S	777/HQ	827,5	169,5	293	260	270	270	1831,5	1407	250	907	70	815	695	125	(1)	645	20	140	42	420	100	(2)	1000	4	895
PM(S)	/2	90	280M	778/HQ	827,5	169,5	293	260	270	270	1882,5	1458	250	958	70	815	695	125	(1)	645	20	140	42	420	100	(2)	1051	4	1023
PM(S)	100H/3	75	280S	779/HQ	902,5	244,5	293	260	270	270	1906,5	1482	250	982	70	815	695	125	(1)	645	20	140	42	420	100	(2)	1000	4	922
PM(S)	/3	90	280M	780/HQ	902,5	244,5	293	260	270	270	1957,5	1533	250	1033	70	815	695	125	(1)	645	20	140	42	420	100	(2)	1051	4	1051
PM(S)	/3	110	315S	781/IQ	902,5	244,5	293	260	270	270	2087,5	1609	250	1109	100	1030	780	125	(1)	730	22	160	50	475	100	(2)	1181	4	1409
PM(S)	/3	132	315M	782/IQ	902,5	244,5	293	260	270	270	2197,5	1668	300	1068	100	1030	780	125	(1)	730	22	160	50	475	100	(2)	1291	4	1484
PM(S/H)	100H/4	90	280M	783/HQ	977,5	319,5	293	260	270	270	2032,5	1608	250	1108	70	815	695	125	(1)	645	20	140	42	420	100	(2)	1051	4	1079
PM(S/H)	/4	110	315S	784/IQ	977,5	319,5	293	260	270	270	2162,5	1684	300	1084	100	1030	780	125	(1)	730	22	160	50	475	100	(2)	1181	4	1438
PM(S/H)	/4	132	315M	785/IQ	977,5	319,5	293	260	270	270	2272,5	1743	300	1143	100	1030	780	125	(1)	730	22	160	50	475	100	(2)	1291	4	1512
PM(S/H)	/4	160	315L	785/IQ	977,5	319,5	293	260	270	270	2272,5	1743	300	1143	100	1030	780	125	(1)	730	22	160	50	475	100	(2)	1291	4	1590
PM(S/H)	/4	200	315L	786/IE4/LQ	977,5	319,5	293	260	270	270	2362,5	1884	300	1284	198	1030	780	125	(1)	730	22	160	50	475	100	(2)	1381	4	1709
PM(S/H)	100H/5	110	315S	787/IQ	1052,5	394,5	293	260	270	270	2237,5	1759	300	1159	100	1030	780	125	(1)	730	22	160	50	475	100	(2)	1181	4	1466
PM(S/H)	/5	132	315M	788/IQ	1052,5	394,5	293	260	270	270	2347,5	1818	300	1218	100	1030	780	125	(1)	730	22	160	50	475	100	(2)	1291	4	1540
PM(S/H)	/5	160	315L	788/IQ	1052,5	394,5	293	260	270	270	2347,5	1818	300	1218	100	1030	780	125	(1)	730	22	160	50	475	100	(2)	1291	4	1618
PM(S/H)	/5	200	315L	789/IE4/LQ	1052,5	394,5	293	260	270	270	2437,5	1959	350	1259	198	1030	780	125	(1)	730	22	160	50	475	100	(2)	1381	4	1736
PM(S/H)	/5	250	355M	790/LQ	1052,5	394,5	293	260	270	270	2582,5	1923	300	1323	100	1136	880	125	(1)	830	22	180	50	535	100	(2)	1526	4	2128
PM(S/H)	100H/6	132	315M	791/IQ	1127,5	469,5	293	260	270	270	2422,5	1893	300	1293	100	1030	780	125	(1)	730	22	160	50	475	100	(2)	1291	4	1568
PM(S/H)	/6	160	315L	791/IQ	1127,5	469,5	293	260	270	270	2422,5	1893	300	1293	100	1030	780	125	(1)	730	22	160	50	475	100	(2)	1291	4	1646
PM(S/H)	/6	200	315L	792/IE4/LQ	1127,5	469,5	293	260	270	270	2512,5	2034	350	1334	198	1030	780	125	(1)	730	22	160	50	475	100	(2)	1381	4	1764
PM(S/H)	/6	250	355M	793/LQ	1127,5	469,5	293	260	270	270	2657,5	2068	350	1368	100	1136	880	125	(1)	830	22	180	50	535	100	(2)	1526	4	2160
PM(S/H)	/6	280	355L	793/LQ	1127,5	469,5	293	260	270	270	2657,5	2068	350	1368	100	1136	880	125	(1)	830	22	180	50	535	100	(2)	1526	4	2285
PM(S/H)	/6	315	355L	793/MQ	1127,5	469,5	293	260	270	270	2657,5	2068	350	1368	100	1136	880	125	(1)	830	22	180	50	535	100	(2)	1526	4	2289

BGAM = Base and coupling

\* = Indicatives values according to the type of motor installed.

○ Motor in IE4 efficiency class according to EU REGULATION 2019/1781. Available in other efficiency classes for non-EU markets.

- (1) PM=25 bar PMS=25 bar PMH=40 bar
- (2) PM=40 bar PMS=63 bar PMH=100 bar

BGAM = Socle et accouplement

\* = Valeurs indicatives en fonction de la marque du moteur utilisé.

○ Moteur en classe de rendement IE4 conformément au RÈGLEMENT UE2019/1781. Disponibilité en différentes classes de rendement pour les marchés hors UE.

- (1) PM=25 bar PMS=25 bar PMH=40 bar
- (2) PM=40 bar PMS=63 bar PMH=100 bar

BGAM = Base giunto e coprigiunto

\* = Valori indicativi in funzione della marca di motore utilizzato.

○ Motore in classe di efficienza IE4 in conformità al REGOLAMENTO UE2019/1781. Disponibili in altre classi di efficienza per mercati extra UE.

- (1) PM=25 bar PMS=25 bar PMH=40 bar
- (2) PM=40 bar PMS=63 bar PMH=100 bar

Selection - dimensions and weights for base mounted electric pumps  
 Sélection - dimensions et poids des électropompes sur socle  
 Selezione - dimensioni e pesi elettropompe su base

COUPLINGS WITH STANDARDIZED ENCLOSED ELECTRIC MOTORS  
 ACCOUPLEMENTS AVEC MOTEURS ÉLECTRIQUES FERMÉS NORMALISÉS  
 ACCOPIAMENTI CON MOTORI ELETTRICI CHIUSI NORMALIZZATI

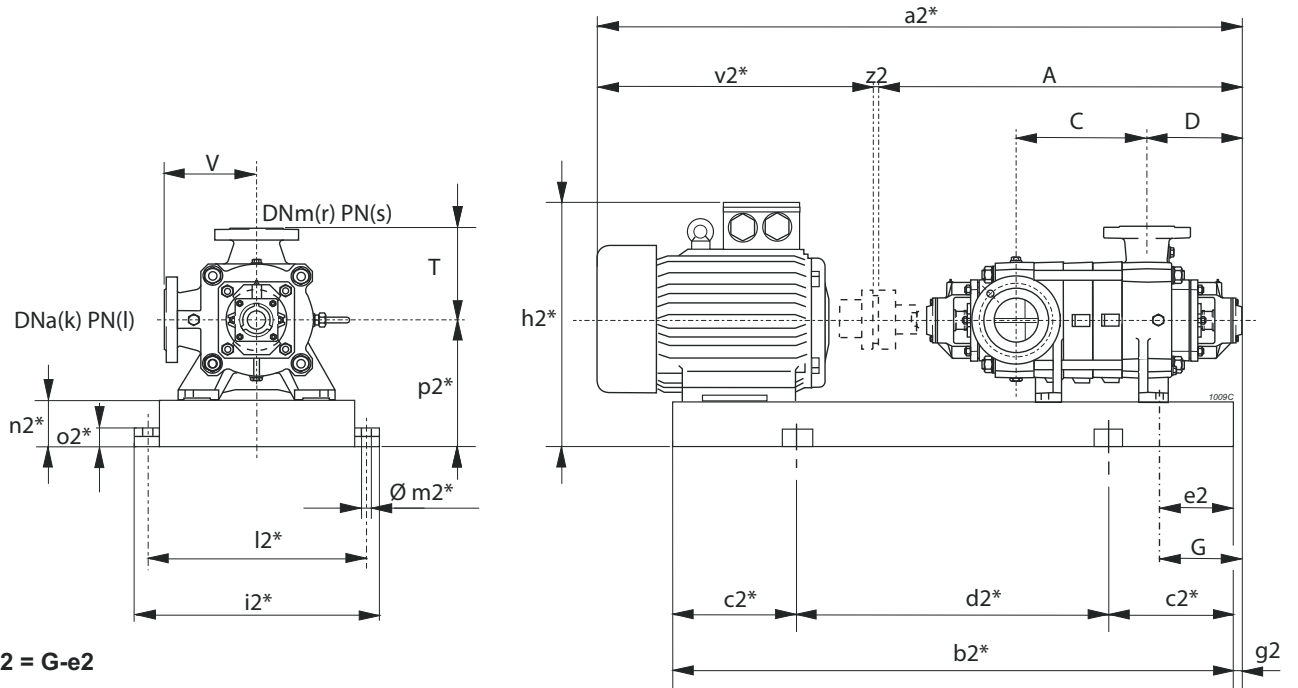

$g2 = G - e2$

\* Valori indicativi in funzione della marca di motore utilizzato  
 Indicatives values according to the type of motor installed

Pump Pompe Pompa	Motor Moteur Motore	BGAM	A	C	D	G	T	V	a2*	b2*	c2*	d2*	e2	h2*	i2*	k	l	l2*	m2*	n2*	o2*	p2*	r	s	v2*	z2	Weight Poids Peso		
Serie Série Serie	Type Type Tipo	[kW]	Size Taille Grand.	Type Type Tipo	[mm]																				[kg]				
PM(S)	100H/2	5,5	132S	730/CN	827,5	169,5	293	260	270	270	1286,5	971	150	671	50	537	590	125	(1)	540	20	120	42	345	100	(2)	455	4	324
PM(S)	/2	7,5	132M	731/DN	827,5	169,5	293	260	270	270	1321,5	1009	150	709	50	537	590	125	(1)	540	20	120	42	345	100	(2)	490	4	335
PM(S)	/2	11	160M	732/EN	827,5	169,5	293	260	270	270	1458,5	1115	200	715	50	596	590	125	(1)	540	20	120	42	345	100	(2)	627	4	433
PM(S)	100H/3	7,5	132M	733/DN	902,5	244,5	293	260	270	270	1396,5	1084	200	684	50	537	590	125	(1)	540	20	120	42	345	100	(2)	490	4	362
PM(S)	/3	11	160M	734/EN	902,5	244,5	293	260	270	270	1533,5	1190	200	790	50	596	590	125	(1)	540	20	120	42	345	100	(2)	627	4	460
PM(S)	/3	15	160L	735/EN	902,5	244,5	293	260	270	270	1533,5	1234	200	834	50	596	590	125	(1)	540	20	120	42	345	100	(2)	627	4	473
PM(S)	/3	18,5	180M	736/FN	902,5	244,5	293	260	270	270	1571,5	1244	200	844	50	615	590	125	(1)	540	20	120	42	345	100	(2)	665	4	500
PM(S/H)	100H/4	11	160M	737/EN	977,5	319,5	293	260	270	270	1608,5	1265	200	865	50	596	590	125	(1)	540	20	120	42	345	100	(2)	627	4	488
PM(S/H)	/4	15	160L	738/EN	977,5	319,5	293	260	270	270	1608,5	1309	200	909	50	596	590	125	(1)	540	20	120	42	345	100	(2)	627	4	501
PM(S/H)	/4	18,5	180M	739/FN	977,5	319,5	293	260	270	270	1646,5	1319	200	919	50	615	590	125	(1)	540	20	120	42	345	100	(2)	665	4	528
PM(S/H)	/4	22	180L	740/FN	977,5	319,5	293	260	270	270	1686,5	1357	250	857	50	615	590	125	(1)	540	20	120	42	345	100	(2)	705	4	549
PM(S/H)	100H/5	15	160L	741/EN	1052,5	394,5	293	260	270	270	1683,5	1384	250	884	50	596	590	125	(1)	540	20	120	42	345	100	(2)	627	4	528
PM(S/H)	/5	18,5	180M	742/FN	1052,5	394,5	293	260	270	270	1721,5	1394	250	894	50	615	590	125	(1)	540	20	120	42	345	100	(2)	665	4	555
PM(S/H)	/5	22	180L	743/FN	1052,5	394,5	293	260	270	270	1761,5	1432	250	932	50	615	590	125	(1)	540	20	120	42	345	100	(2)	705	4	576
PM(S/H)	/5	30	200L	744/GN	1052,5	394,5	293	260	270	270	1814,5	1467	250	967	50	645	590	125	(1)	540	20	120	42	345	100	(2)	758	4	639
PM(S/H)	100H/6	15	160L	745/EN	1127,5	469,5	293	260	270	270	1758,5	1459	250	959	50	596	590	125	(1)	540	20	120	42	345	100	(2)	627	4	555
PM(S/H)	/6	18,5	180M	746/FN	1127,5	469,5	293	260	270	270	1796,5	1469	250	969	50	615	590	125	(1)	540	20	120	42	345	100	(2)	665	4	582
PM(S/H)	/6	22	180L	747/FN	1127,5	469,5	293	260	270	270	1836,5	1507	250	1007	50	615	590	125	(1)	540	20	120	42	345	100	(2)	705	4	603
PM(S/H)	/6	30	200L	748/GN	1127,5	469,5	293	260	270	270	1889,5	1542	250	1042	50	645	590	125	(1)	540	20	120	42	345	100	(2)	758	4	666
PM(S/H)	/6	37	225S	749/HQ	1127,5	469,5	293	260	270	270	1924,5	1573	250	1073	50	675	590	125	(1)	540	20	120	42	345	100	(2)	793	4	711

BGAM = Base and coupling

\* = Indicatives values according to the type of motor installed.

- (1) PM=25 bar PMS=25 bar PMH=40 bar  
 (2) PM=40 bar PMS=63 bar PMH=100 bar

BGAM = Socle et accouplement

\* = Valeurs indicatives en fonction de la marque du moteur utilisé.

- (1) PM=25 bar PMS=25 bar PMH=40 bar  
 (2) PM=40 bar PMS=63 bar PMH=100 bar

BGAM = Base giunto e coprigiunto

\* = Valori indicativi in funzione della marca di motore utilizzato.

- (1) PM=25 bar PMS=25 bar PMH=40 bar  
 (2) PM=40 bar PMS=63 bar PMH=100 bar