

Utilization field / Champ d'utilisation / Campo di utilizzo ≥ 67% η		
Stage number: compatibly with the maximum pressure. Nombre d'étages: compatible avec la pression maximum. Numero stadi: compatibilmente con la pressione massima di esercizio.		
Type Type Tipo	MIN.	MAX.
PMAL	2	5
PMALS	2	5
PMALH	2	8
NB. For two-stage pumps only, reduce efficiency by one point. Diminuer le rendement d'un point seulement pour les pompes à deux étages. Solamente per le pompe a due stadi, ridurre di un punto il rendimento.		

Wet moment of inertia J Moment d'inertie J mouillé Momento d'inertia J bagnato J=1/4PD ² - [kg m ²]		
Impeller type Roue type Girante tipo	PMAL(S/H)125/1	For each additional stage Pour chaque étage en plus Per ogni stadio in più
Cast iron Fonte Ghisa	0,0942	0,084
Bronze Bronze Bronzo	0,1025	0,0923

Maximum permissible power Puissances maximums admissibles Massime potenze ammissibili	
Type Type Tipo	N/n MAX.
PMAL	0,18
PMALS	0,18
PMALH	0,25
For seal limits and calculation formulas of the maximum permissible powers, see technical data section. Consulter la section Données techniques pour connaître les limites des joints et les formules pour le calcul des puissances maximales admises. Per i limiti tenute e le formule di calcolo delle massime potenze ammissibili, vedere sezione dati tecnici.	

PERFORMANCES EACH INTERMEDIATE STAGE
CARACTERISTIQUES POUR CHAQUE ETAGE
PRESTAZIONI PER STADIO

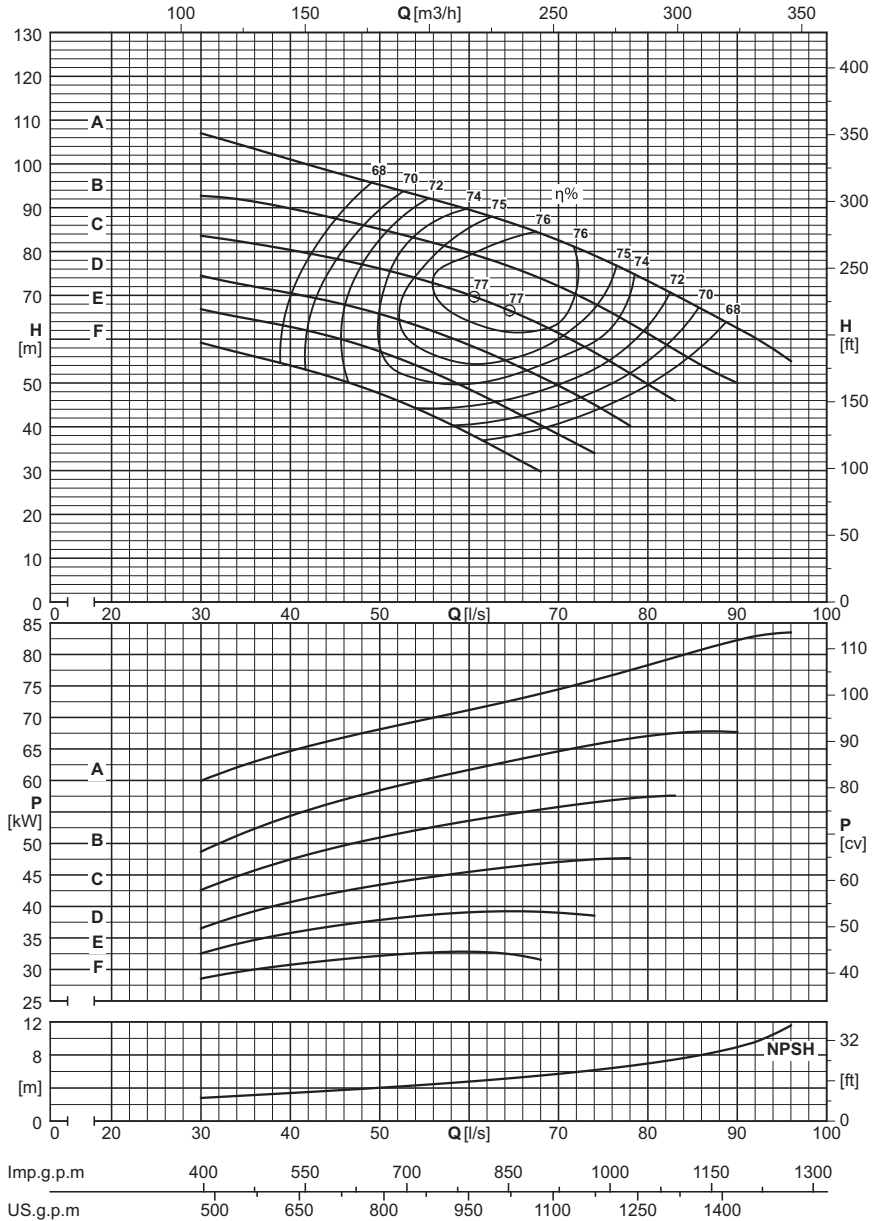

		Capacity - Debit - Portata																
Dna x DNm	Impeller type Roue type Girante tipo	[l/s]	0	32	36	40	44	48	52	56	60	64	68	72	76	80	84	88
		[m³/h]	0	115,2	129,6	144	158,4	172,8	187,2	201,6	216	230,4	244,8	259,2	273,6	288	302,4	316,8
		[l/min]	0	1920	2160	2400	2640	2880	3120	3360	3600	3840	4080	4320	4560	4800	5040	5280

		PMAL(S/H)125/1																
200x125	F	[m]	66		56	54	51	49	46,5	42,5	38,5	34						
200x125	F	[kW]			30	30,5	31,5	32	32,5	32,5	33	32,5						
200x125	E	[m]	74		65	62	60	58	55	52	48,5	44,5	41	36,5	33			
200x125	E	[kW]			34	36,5	37	37	39	40	40	39	39,5	40	39,5			
200x125	D	[m]	82			70	70	66	65	61	58	55	51	47	43	39		
200x125	D	[kW]				40,5	41	43	43,5	45	45,5	47	47	47	48	49		
200x125	C	[m]	93			82	78	75	75	72	70	66	63	59	55	49,5	45,5	
200x125	C	[kW]				46,5	50	51,5	51,5	53	53	55	55	56,5	57,5	57,5	58,5	
200x125	B	[m]	105			88	85	87	84	81	78	77	73	70	65	61	56	52
200x125	B	[kW]				55	57,5	57	60	61	63	62,5	64	66	65,5	66,5	68	68,5
200x125	A	[m]	122				98	95	92	90	90	87	84	80	77	73	68	64
200x125	A	[kW]					66,5	68	70	71,5	70	72	73,5	75	77	79	79	81

		NPSH																
	[m]		2,9	3,2	3,4	3,6	3,9	4,2	4,5	4,8	5,1	5,5	5,9	6,4	7	7,6	8,6	

Overall dimensions and weights
 Dimensions d'encombrement et poids
 Dimensioni di ingombro e pesi

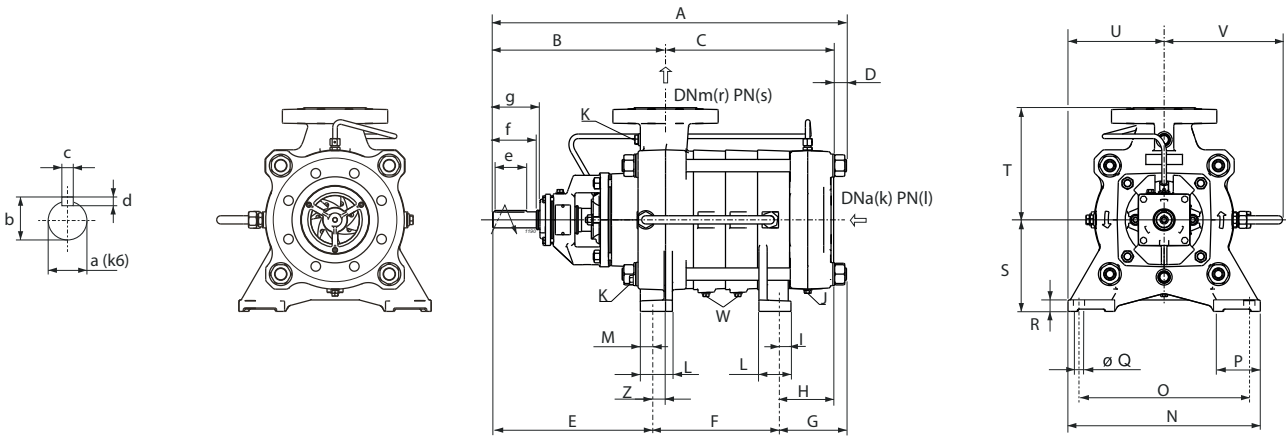

Series Série Serie	Type Type Tipo	A	B	C	D	E	F	G	H	S	T	U	V	Z	Weight Poids Peso
		[mm]													
PMAL(S/H)	125/2	857	462	357	37,5	419	200	203	165	280	320	326	320	43	369
PMAL(S/H)	125/3	922	462	422	37,5	419	300	203	165	280	320	326	320	43	416
PMAL(S/H)	125/4	987	462	487	37,5	419	400	203	165	280	320	326	320	43	463
PMAL(S/H)	125/5	1052	462	552	37,5	419	500	203	165	280	320	326	320	43	510
PMAL(S/H)	125/6	1117	462	617	37,5	419	600	203	165	280	320	326	320	43	557
PMAL(S/H)	125/7	1182	462	682	37,5	419	700	203	165	280	320	326	320	43	604
PMAL(S/H)	125/8	1247	462	747	37,5	419	800	203	165	280	320	326	320	43	651
PMAL(S/H)	125/9	1312	462	812	37,5	419	900	203	165	280	320	326	320	43	698
PMAL(S/H)	125/10	1377	462	877	37,5	419	1000	203	165	280	320	326	320	43	745

Foot dimensions Dimensions des pieds Dimensioni dei piedi							
I	L	M	N	O	P	Q	R
[mm]							
29,5	100	32	570	460	145	24	35

Shaft projection Saille d'arbre Sporgenza d'albero						
a	b	c	d	e	f	g
[mm]						
45	48,5	14	9	100	110	125

Type Type Tipo	Flanges Brides Flange			
	(k) DNa [mm]	(l) PN [bar]	(r) DNm [mm]	(s) PN [bar]
PMAL	200	40	125	40
PMALS	200	40	125	63
PMALH	200	40	125	100

Plugs Bouchons Tappi		
J	K	W
G1/4	G 1/2	G1/4

Selection - dimensions and weights for base mounted electric pumps
Sélection - dimensions et poids des électropompes sur socle
 Selezione - dimensioni e pesi elettropompe su base

COUPLINGS WITH STANDARDIZED ENCLOSED ELECTRIC MOTORS
ACCOUPLLEMENTS AVEC MOTEURS ÉLECTRIQUES FERMÉS NORMALISÉS
ACCOPIAMENTI CON MOTORI ELETTRICI CHIUSI NORMALIZZATI

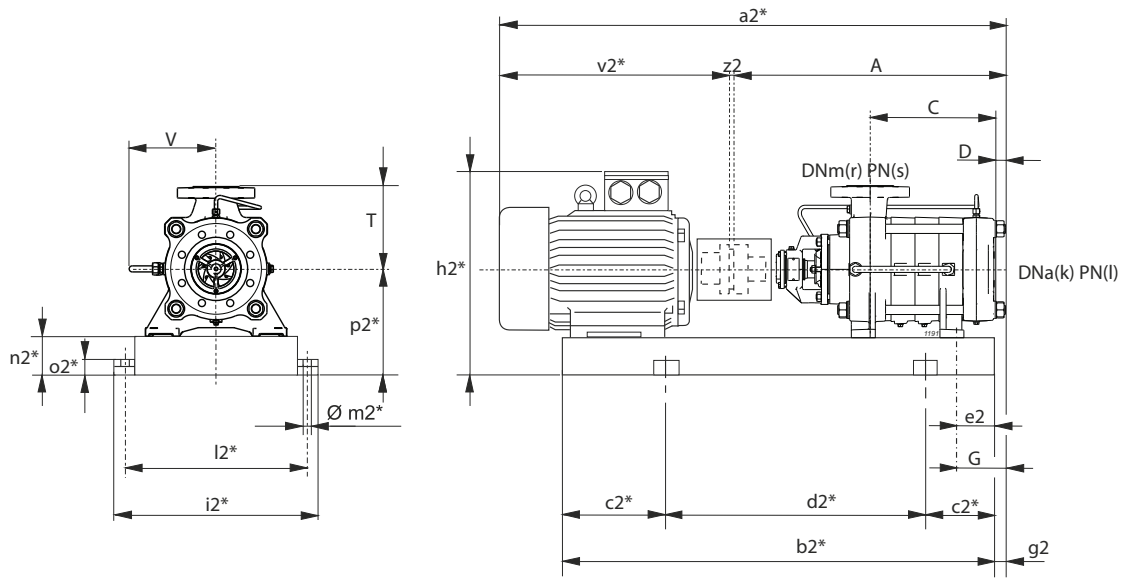

g2 = G-e2

*** Valori indicativi in funzione della marca di motore utilizzato**
Indicatives values according to the type of motor installed

Pump Pompe Pompa		Motor Moteur Motore		BGAMA	A	C	D	G	T	V	a2*	b2*	c2*	d2*	e2	h2*	i2*	k	l	l2*	m2*	n2*	o2*	p2*	r	s	v2*	z2	Weight Poids Peso
Series Série Serie	Type Type Tipo	[kW]	Size Taille Grand.	Type Type Tipo	[mm]																								[kg]
PMAL(S/H)	125/2	75	280S	82/HR	856,5	357	37,5	202,5	320	320	1860,5	1448	250	948	60	815	700	200	40	650	20	140	42	420	125	(2)	1000	4	1034
PMAL(S/H)	/2	90	280M	81/HR	856,5	357	37,5	202,5	320	320	1911,5	1499	250	999	60	815	700	200	40	650	20	140	42	420	125	(2)	1051	4	1109
PMAL(S/H)	/2	110	315S	80/IR	856,5	357	37,5	202,5	320	320	2041,5	1575	250	1075	90	1030	780	200	40	730	22	160	50	475	125	(2)	1181	4	1472
PMAL(S/H)	/2	132	315M	335/IR	856,5	357	37,5	202,5	320	320	2151,5	1685	300	1085	90	1030	780	200	40	730	22	160	50	475	125	(2)	1291	4	1548
PMAL(S/H)	/2	160	315L	335/IR	856,5	357	37,5	202,5	320	320	2151,5	1685	300	1085	90	1030	780	200	40	730	22	160	50	475	125	(2)	1291	4	1626
PMAL(S/H)	/2	200	315L	336/IE4/LR	856,5	357	37,5	202,5	320	320	2241,5	1775	300	1175	198	1030	780	200	40	730	22	160	50	475	125	(2)	1381	4	1771
PMAL(S/H)	125/3	110	315S	85/IR	921,5	422	37,5	202,5	320	320	2106,5	1675	300	1075	90	1030	780	200	40	730	22	160	50	475	125	(2)	1181	4	1523
PMAL(S/H)	/3	132	315M	84/IR	921,5	422	37,5	202,5	320	320	2216,5	1734	300	1134	90	1030	780	200	40	730	22	160	50	475	125	(2)	1291	4	1597
PMAL(S/H)	/3	160	315L	338/LR	921,5	422	37,5	202,5	320	320	2216,5	1785	300	1185	90	1030	780	200	40	730	22	160	50	475	125	(2)	1291	4	1677
PMAL(S/H)	/3	200	315L	338/IE4/LR	921,5	422	37,5	202,5	320	320	2306,5	1875	300	1275	198	1030	780	200	40	730	22	160	50	475	125	(2)	1381	4	1822
PMAL(S/H)	/3	250	355M	339/LR	921,5	422	37,5	202,5	320	320	2451,5	1929	300	1329	110	1136	880	200	40	830	22	180	50	535	125	(2)	1526	4	2222
PMAL(S/H)	/3	280	355L	339/LR	921,5	422	37,5	202,5	320	320	2451,5	1929	300	1329	110	1136	880	200	40	830	22	180	50	535	125	(2)	1526	4	2347
PMAL(S/H)	125/4	160	315L	87/IR	986,5	487	37,5	202,5	320	320	2281,5	1885	300	1285	90	1030	780	200	40	730	22	160	50	475	125	(2)	1291	4	1728
PMAL(S/H)	/4	200	315L	806/IE4/LR	986,5	487	37,5	202,5	320	320	2371,5	1975	350	1275	198	1030	780	200	40	730	22	160	50	475	125	(2)	1381	4	1873
PMAL(S/H)	/4	250	355M	340/LR	986,5	487	37,5	202,5	320	320	2516,5	1959	350	1259	110	1136	880	200	40	830	22	180	50	535	125	(2)	1526	4	2273
PMAL(S/H)	/4	280	355L	340/MR	986,5	487	37,5	202,5	320	320	2516,5	2029	350	1329	110	1136	880	200	40	830	22	180	50	535	125	(2)	1526	4	2398
PMAL(S/H)	/4	315	355L	340/MR	986,5	487	37,5	202,5	320	320	2516,5	2029	350	1329	110	1136	880	200	40	830	22	180	50	535	125	(2)	1526	4	2398
PMAL(S/H)	/4	355	355L	340/MR	986,5	487	37,5	202,5	320	320	2516,5	2029	350	1329	110	1136	880	200	40	830	22	180	50	535	125	(2)	1526	4	2388
PMAL(S/H)	125/5	200	315L	809/IE4/LR	1051,5	552	37,5	202,5	320	320	2436,5	2075	350	1375	198	1030	780	200	40	730	22	160	50	475	125	(2)	1381	4	1924
PMAL(S/H)	/5	250	355M	88/LR	1051,5	552	37,5	202,5	320	320	2581,5	2059	350	1359	110	1136	880	200	40	830	22	180	50	535	125	(2)	1526	4	2321
PMAL(S/H)	/5	280	355L	341/MR	1051,5	552	37,5	202,5	320	320	2581,5	2129	350	1429	110	1136	880	200	40	830	22	180	50	535	125	(2)	1526	4	2450
PMAL(S/H)	/5	315	355L	341/MR	1051,5	552	37,5	202,5	320	320	2581,5	2129	350	1429	110	1136	880	200	40	830	22	180	50	535	125	(2)	1526	4	2450
PMAL(S/H)	/5	355	355L	341/MR	1051,5	552	37,5	202,5	320	320	2581,5	2129	350	1429	110	1136	880	200	40	830	22	180	50	535	125	(2)	1526	4	2440
PMAL(H)	125/6	250	355M	4000/LR	1116,5	617	37,5	202,5	320	320	2646,5	2229	350	1529	72	1136	880	200	40	830	22	180	50	535	125	(2)	1526	4	2372
PMAL(H)	/6	280	355L	4000/LR	1116,5	617	37,5	202,5	320	320	2646,5	2229	350	1529	72	1136	880	200	40	830	22	180	50	535	125	(2)	1526	4	2497
PMAL(H)	/6	315	355L	4000/MR	1116,5	617	37,5	202,5	320	320	2646,5	2229	350	1529	110	1136	880	200	40	830	22	180	50	535	125	(2)	1526	4	2501
PMAL(H)	/6	355	355L	4000/MR	1116,5	617	37,5	202,5	320	320	2646,5	2229	350	1529	110	1136	880	200	40	830	22	180	50	535	125	(2)	1526	4	2491
PMAL(H)	125/7	250	355M	4001/LR	1181,5	682	37,5	202,5	320	320	2711,5	2329	400	1529	110	1136	880	200	40	830	22	180	50	535	125	(2)	1526	4	2427
PMAL(H)	/7	280	355L	4001/LR	1181,5	682	37,5	202,5	320	320	2711,5	2329	400	1529	110	1136	880	200	40	830	22	180	50	535	125	(2)	1526	4	2552
PMAL(H)	/7	315	355L	4001/MR	1181,5	682	37,5	202,5	320	320	2711,5	2329	400	1529	110	1136	880	200	40	830	22	180	50	535	125	(2)	1526	4	2552
PMAL(H)	/7	355	355L	4001/MR	1181,5	682	37,5	202,5	320	320	2711,5	2329	400	1529	110	1136	880	200	40	830	22	180	50	535	125	(2)	1526	4	2542
PMAL(H)	125/8	280	355L	4002/MR	1246,5	747	37,5	202,5	320	320	2776,5	2429	400	1629	110	1136	880	200	40	830	22	180	50	535	125	(2)	1526	4	2604
PMAL(H)	/8	315	355L	4002/MR	1246,5	747	37,5	202,5	320	320	2776,5	2429	400	1629	110	1136	880	200	40	830	22	180	50	535	125	(2)	1526	4	2604
PMAL(H)	/8	355	355L	4002/MR	1246,5	747	37,5	202,5	320	320	2776,5	2429	400	1629	110	1136	880	200	40	830	22	180	50	535	125	(2)	1526	4	2594

BGAMA = Base and coupling

BGAMA = Socle et accouplement

BGAMA = Base giunto e coprigiunto

* = Indicatives values according to the type of motor installed

* = Valeurs indicatives en fonction de la marque du moteur utilisé

* = Valori indicativi in funzione della marca di motore utilizzato.

○ Motor in IE4 efficiency class according to EU REGULATION 2019/1781. Available in other efficiency classes for non-EU markets.

○ Moteur en classe de rendement IE4 conformément au RÈGLEMENT UE2019/1781. Disponibili en différentes classes de rendement pour les marchés hors UE.

○ Motore in classe di efficienza IE4 in conformità al REGOLAMENTO UE2019/1781. Disponibili in altre classi di efficienza per mercati extra UE.

(2) PMAL=40 bar PMALS=63 bar PMALH=100 bar

(2) PMAL=40 bar PMALS=63 bar PMALH=100 bar

(2) PMAL=40 bar PMASL=63 bar PMALH=100 bar

Contact the sales network for couplings exceeding 355 kW.

Pour des accouplements supérieurs à 355 kW, contacter notre réseau de vente.

Per accoppiamenti superiori al 355 kW, contattare la rete di vendita.

Selection - dimensions and weights for base mounted electric pumps
Sélection - dimensions et poids des électropompes sur socle
 Selezione - dimensioni e pesi elettropompe su base

COUPLINGS WITH STANDARDIZED ENCLOSED ELECTRIC MOTORS
 ACCOUPLEMENTS AVEC MOTEURS ÉLECTRIQUES FERMÉS NORMALISÉS
 ACCOPPIAMENTI CON MOTORI ELETTRICI CHIUSI NORMALIZZATI

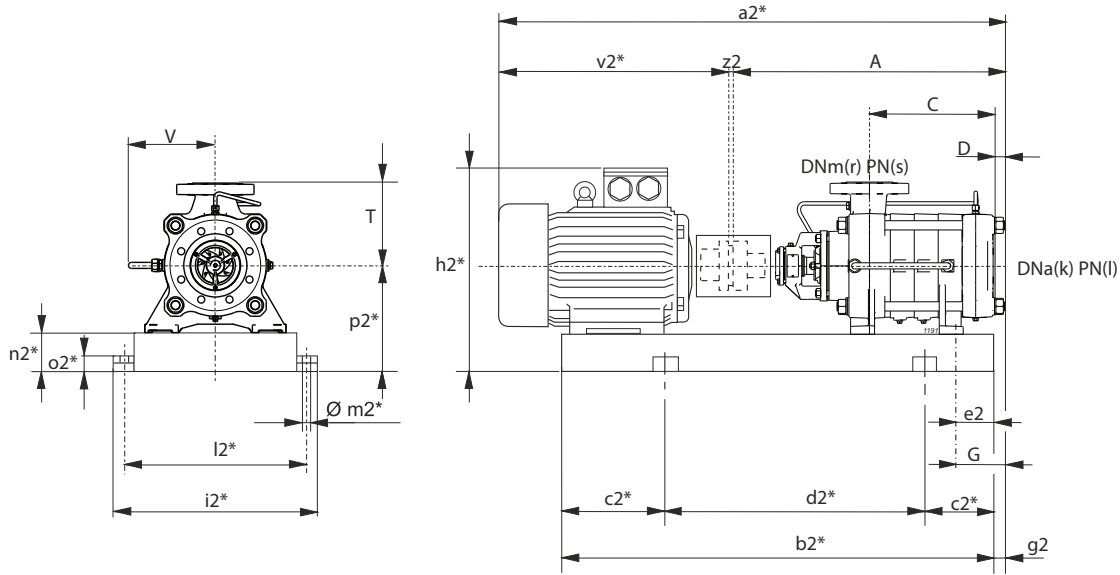

g2 = G-e2

* Valori indicativi in funzione della marca di motore utilizzato
Indicatives values according to the type of motor installed

Pump Pompe Pompa		Motor Moteur Motore		BGAMA	A	C	D	G	T	V	a2*	b2*	c2*	d2*	e2	h2*	i2*	k	l	l2*	m2*	n2*	o2*	p2*	r	s	v2*	z2	Weight Poids Peso
Series Série Serie	Type Type Tipo	[kW]	Size Taille Grand.	Type Type Tipo	[mm]																								[kg]
PMAL(S/H)	125/2	11	160M	870/EP	856,5	357	37,5	202,5	320	320	1487,5	1176	200	776	60	671	700	200	40	650	20	140	42	420	125	(2)	627	4	609
PMAL(S/H)	/2	15	160L	345/EP	856,5	357	37,5	202,5	320	320	1487,5	1220	200	820	60	671	700	200	40	650	20	140	42	420	125	(2)	627	4	622
PMAL(S/H)	/2	18,5	180M	346/FP	856,5	357	37,5	202,5	320	320	1525,5	1230	200	830	60	690	700	200	40	650	20	140	42	420	125	(2)	665	4	701
PMAL(S/H)	/2	22	180L	347/FP	856,5	357	37,5	202,5	320	320	1565,5	1268	200	868	60	690	700	200	40	650	20	140	42	420	125	(2)	705	4	722
PMAL(S/H)	125/3	15	160L	811/IR	921,5	422	37,5	202,5	320	320	1552,5	1320	200	920	60	671	700	200	40	650	20	140	42	420	125	(2)	627	4	672
PMAL(S/H)	/3	18,5	180M	850/FP	921,5	422	37,5	202,5	320	320	1590,5	1330	200	930	60	690	700	200	40	650	20	140	42	420	125	(2)	665	4	751
PMAL(S/H)	/3	22	180L	849/FP	921,5	422	37,5	202,5	320	320	1630,5	1368	250	868	60	690	700	200	40	650	20	140	42	420	125	(2)	705	4	772
PMAL(S/H)	/3	30	200L	349/GP	921,5	422	37,5	202,5	320	320	1683,5	1403	250	903	60	720	700	200	40	650	20	140	42	420	125	(2)	758	4	806
PMAL(S/H)	/3	37	225S	350/HR	921,5	422	37,5	202,5	320	320	1718,5	1434	250	934	60	750	700	200	40	650	20	140	42	420	125	(2)	793	4	820
PMAL(S/H)	125/4	18,5	180M	812/FP	986,5	487	37,5	202,5	320	320	1655,5	1430	250	930	60	690	700	200	40	650	20	140	42	420	125	(2)	665	4	801
PMAL(S/H)	/4	22	180L	871/FP	986,5	487	37,5	202,5	320	320	1695,5	1468	250	968	60	690	700	200	40	650	20	140	42	420	125	(2)	705	4	822
PMAL(S/H)	/4	30	200L	352/GP	986,5	487	37,5	202,5	320	320	1748,5	1503	250	1003	60	720	700	200	40	650	20	140	42	420	125	(2)	758	4	857
PMAL(S/H)	/4	37	225S	471/HR	986,5	487	37,5	202,5	320	320	1783,5	1534	250	1034	60	750	700	200	40	650	20	140	42	420	125	(2)	793	4	870
PMAL(S/H)	/4	45	225M	472/HR	986,5	487	37,5	202,5	320	320	1808,5	1559	250	1059	60	750	700	200	40	650	20	140	42	420	125	(2)	818	4	913
PMAL(S/H)	125/5	22	180L	814/FP	1051,5	552	37,5	202,5	320	320	1760,5	1568	250	1068	60	690	700	200	40	650	20	140	42	420	125	(2)	705	4	872
PMAL(S/H)	/5	30	200L	851/GP	1051,5	552	37,5	202,5	320	320	1813,5	1603	250	1103	60	720	700	200	40	650	20	140	42	420	125	(2)	758	4	907
PMAL(S/H)	/5	37	225S	813/HR	1051,5	552	37,5	202,5	320	320	1848,5	1634	250	1134	60	750	700	200	40	650	20	140	42	420	125	(2)	793	4	920
PMAL(S/H)	/5	45	225M	475/HR	1051,5	552	37,5	202,5	320	320	1873,5	1659	300	1059	60	750	700	200	40	650	20	140	42	420	125	(2)	818	4	963
PMAL(S/H)	/5	55	250M	476/IR	1051,5	552	37,5	202,5	320	320	1935,5	1701	300	1101	60	795	700	200	40	650	20	140	42	420	125	(2)	880	4	1082
PMAL(S/H)	125/6	30	200L	815/GP	1116,5	617	37,5	202,5	320	320	1878,5	1703	300	1103	60	720	700	200	40	650	20	140	42	420	125	(2)	758	4	957
PMAL(S/H)	/6	37	225S	852/HR	1116,5	617	37,5	202,5	320	320	1913,5	1734	300	1134	60	750	700	200	40	650	20	140	42	420	125	(2)	793	4	970
PMAL(S/H)	/6	45	225M	478/HR	1116,5	617	37,5	202,5	320	320	1938,5	1759	300	1159	60	750	700	200	40	650	20	140	42	420	125	(2)	818	4	1013
PMAL(S/H)	/6	55	250M	479/IR	1116,5	617	37,5	202,5	320	320	2000,5	1801	300	1201	60	795	700	200	40	650	20	140	42	420	125	(2)	880	4	1133
PMAL(S/H)	/6	75	280S	480/IR	1116,5	617	37,5	202,5	320	320	2133,5	1848	300	1248	60	815	700	200	40	650	20	140	42	420	125	(2)	1013	4	1274
PMAL(S/H)	125/7	30	200L	817/GP	1181,5	682	37,5	202,5	320	320	1943,5	1803	300	1203	60	720	700	200	40	650	20	140	42	420	125	(2)	758	4	1007
PMAL(S/H)	/7	37	225S	853/HR	1181,5	682	37,5	202,5	320	320	1978,5	1834	300	1234	60	750	700	200	40	650	20	140	42	420	125	(2)	793	4	1020
PMAL(S/H)	/7	45	225M	816/HR	1181,5	682	37,5	202,5	320	320	2003,5	1859	300	1259	60	750	700	200	40	650	20	140	42	420	125	(2)	818	4	1063
PMAL(S/H)	/7	55	250M	482/IR	1181,5	682	37,5	202,5	320	320	2065,5	1901	300	1301	60	795	700	200	40	650	20	140	42	420	125	(2)	880	4	1183
PMAL(S/H)	/7	75	280S	483/IR	1181,5	682	37,5	202,5	320	320	2198,5	1948	300	1348	60	815	700	200	40	650	20	140	42	420	125	(2)	1013	4	1324
PMAL(S/H)	/7	90	280M	484/LR	1181,5	682	37,5	202,5	320	320	2249,5	1999	350	1299	60	815	700	200	40	650	20	140	42	420	125	(2)	1064	4	1389
PMAL(S/H)	125/8	37	225S	819/HR	1246,5	747	37,5	202,5	320	320	2043,5	1934	300	1334	60	750	700	200	40	650	20	140	42	420	125	(2)	793	4	1071
PMAL(S/H)	/8	45	225M	872/HR	1246,5	747	37,5	202,5	320	320	2068,5	1959	350	1259	60	750	700	200	40	650	20	140	42	420	125	(2)	818	4	1113

BGAMA = Base and coupling

* = Indicatives values according to the type of motor installed

○ Motor in IE4 efficiency class according to EU REGULATION 2019/1781. Available in other efficiency classes for non-EU markets.

(2) PMAL=40 bar PMALS=63 bar PMALH=100 bar

BGAMA = Socle et accouplement

* = Valeurs indicatives en fonction de la marque du moteur utilisé

○ Moteur en classe de rendement IE4 conformément au RÈGLEMENT UE2019/1781. Disponibilité en différentes classes de rendement pour les marchés hors UE.

(2) PMAL=40 bar PMALS=63 bar PMALH=100 bar

BGAMA = Base giunto e coprigiunto

* = Valori indicativi in funzione della marca di motore utilizzato.

○ Motore in classe di efficienza IE4 in conformità al REGOLAMENTO UE2019/1781. Disponibili in altre classi di efficienza per mercati extra UE.

(2) PMAL=40 bar PMALS=63 bar PMALH=100 bar

Selection - dimensions and weights for base mounted electric pumps
Sélection - dimensions et poids des électropompes sur socle
 Selezione - dimensioni e pesi elettropompe su base

COUPLINGS WITH STANDARDIZED ENCLOSED ELECTRIC MOTORS
 ACCOUPLEMENTS AVEC MOTEURS ÉLECTRIQUES FERMÉS NORMALISÉS
 ACCOPIAMENTI CON MOTORI ELETTRICI CHIUSI NORMALIZZATI

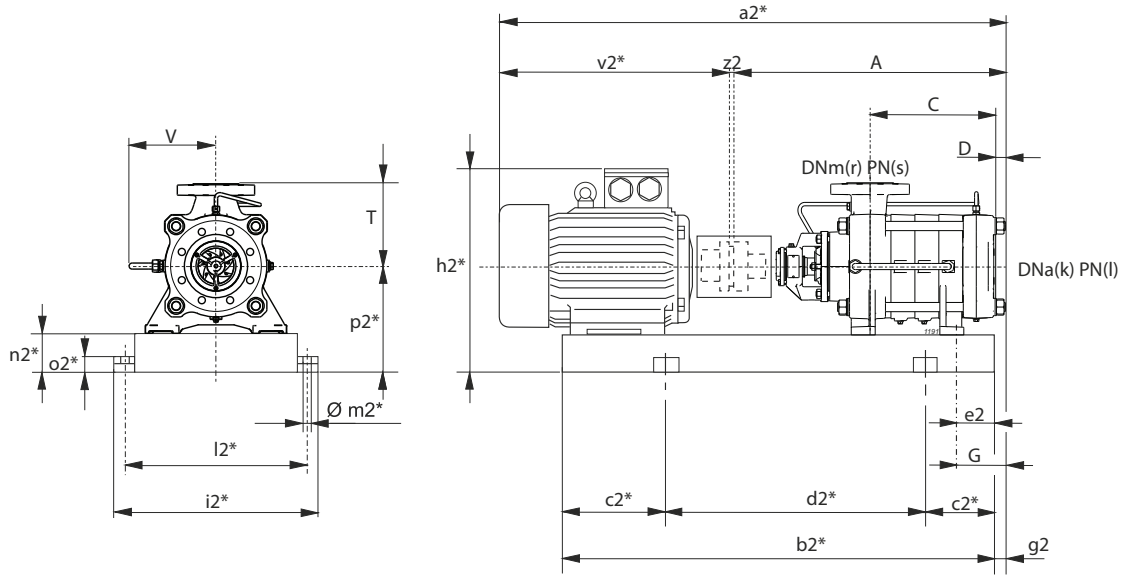

$g_2 = G - e_2$

* Valori indicativi in funzione della marca di motore utilizzato
Indicatives values according to the type of motor installed

Pump Pompe Pompa	Motor Moteur Motore	BGAMA	A	C	D	G	T	V	a ₂ *	b ₂ *	c ₂ *	d ₂ *	e ₂	h ₂ *	i ₂ *	k	l	l ₂ *	m ₂ *	n ₂ *	o ₂ *	p ₂ *	r	s	v ₂ *	z ₂	Weight Poids Peso		
Series Série Serie	Type Type Tipo	Size Taille Grand.	Type Type Tipo	[mm]																						[kg]			
PMAL(S/H)	/8	55	250M	818/IR	1246,5	747	37,5	202,5	320	320	2130,5	2001	350	1301	60	795	700	200	40	650	20	140	42	420	125	(2)	880	4	1233
PMAL(S/H)	/8	75	280S	486/IR	1246,5	747	37,5	202,5	320	320	2263,5	2048	350	1348	60	815	700	200	40	650	20	140	42	420	125	(2)	1013	4	1374
PMAL(S/H)	/8	90	280M	487/LR	1246,5	747	37,5	202,5	320	320	2314,5	2099	350	1399	60	815	700	200	40	650	20	140	42	420	125	(2)	1064	4	1439
PMAL(S/H)	125/9	37	225S	821/HR	1311,5	812	37,5	202,5	320	320	2108,5	2034	350	1334	60	750	700	200	40	650	20	140	42	420	125	(2)	793	4	1121
PMAL(S/H)	/9	45	225M	854/HR	1311,5	812	37,5	202,5	320	320	2133,5	2059	350	1359	60	750	700	200	40	650	20	140	42	420	125	(2)	818	4	1164
PMAL(S/H)	/9	55	250M	873/IR	1311,5	812	37,5	202,5	320	320	2195,5	2101	350	1401	60	795	700	200	40	650	20	140	42	420	125	(2)	880	4	1283
PMAL(S/H)	/9	75	280S	490/IR	1311,5	812	37,5	202,5	320	320	2328,5	2148	350	1448	60	815	700	200	40	650	20	140	42	420	125	(2)	1013	4	1425
PMAL(S/H)	/9	90	280M	491/LR	1311,5	812	37,5	202,5	320	320	2379,5	2199	350	1499	60	815	700	200	40	650	20	140	42	420	125	(2)	1064	4	1489
PMAL(S/H)	/9	110	315S	492/LR	1311,5	812	37,5	202,5	320	320	2526,5	2305	400	1505	90	1030	780	200	40	730	22	160	50	475	125	(2)	1211	4	1824
PMAL(S/H)	125/10	45	225M	822/HR	1376,5	877	37,5	202,5	320	320	2198,5	2159	350	1459	60	750	700	200	40	650	20	140	42	420	125	(2)	818	4	1214
PMAL(S/H)	/10	55	250M	874/IR	1376,5	877	37,5	202,5	320	320	2260,5	2201	350	1501	60	795	700	200	40	650	20	140	42	420	125	(2)	880	4	1333
PMAL(S/H)	/10	75	280S	494/IR	1376,5	877	37,5	202,5	320	320	2393,5	2248	350	1548	60	815	700	200	40	650	20	140	42	420	125	(2)	1013	4	1475
PMAL(S/H)	/10	90	280M	495/LR	1376,5	877	37,5	202,5	320	320	2444,5	2299	400	1499	60	815	700	200	40	650	20	140	42	420	125	(2)	1064	4	1539
PMAL(S/H)	/10	110	315S	496/LR	1376,5	877	37,5	202,5	320	320	2591,5	2405	400	1605	90	1030	780	200	40	730	22	160	50	475	125	(2)	1211	4	1875

BGAMA = Base and coupling

BGAMA = Socle et accouplement

BGAMA = Base giunto e coprigiunto

* = Indicatives values according to the type of motor installed

* = Valeurs indicatives en fonction de la marque du moteur utilisé

* = Valori indicativi in funzione della marca di motore utilizzato.

○ Motor in IE4 efficiency class according to EU REGULATION 2019/1781. Available in other efficiency classes for non-EU markets.

○ Moteur en classe de rendement IE4 conformément au RÈGLEMENT UE2019/1781. Disponibilités en différentes classes de rendement pour les marchés hors UE.

○ Motore in classe di efficienza IE4 in conformità al REGOLAMENTO UE2019/1781. Disponibili in altre classi di efficienza per mercati extra UE.

(2) PMAL=40 bar PMALS=63 bar PMALH=100 bar

(2) PMAL=40 bar PMALS=63 bar PMALH=100 bar

(2) PMAL=40 bar PMALS=63 bar PMALH=100 bar