

Utilization field Champ d'utilisation Campo di utilizzo ≥ 65% η		
Stage number: compatibly with the maximum pressure. Nombre d'étages: compatible avec la pression maximum. Numero stadi: compatibilmente con la pressione massima di esercizio.		
Type Type Tipo	MIN.	MAX.
PMA	2	11
PMAS	2	11
PMAH	4	11
NB. For two-stage pumps only, reduce efficiency by one point. Diminuer le rendement d'un point seulement pour les pompes à deux étages. Solamente per le pompe a due stadi, ridurre di un punto il rendimento.		

Wet moment of inertia J Moment d'inertie J mouillé Momento d'inertzia J bagnato J=1/4PD ² - [kg m ²]		
Impeller type Roue type Girante tipo	PMA(S/H)100/1	For each additional stage Pour chaque étage en plus Per ogni stadio in più
Cast iron Fonte Ghisa	0,0309	0,0280
Bronze Bronze Bronzo	0,0343	0,0310

Maximum permissible power Puissances maximums admissibles Massime potenze ammissibili	
Type Type Tipo	N/n MAX.
PMA	0,08
PMAS	0,08
PMAH	0,13
For seal limits and calculation formulas of the maximum permissible powers, see technical data section. Consulter la section Données techniques pour connaître les limites des joints et les formules pour le calcul des puissances maximales admises. Per i limiti tenute e le formule di calcolo delle massime potenze ammissibili, vedere sezione dati tecnici.	

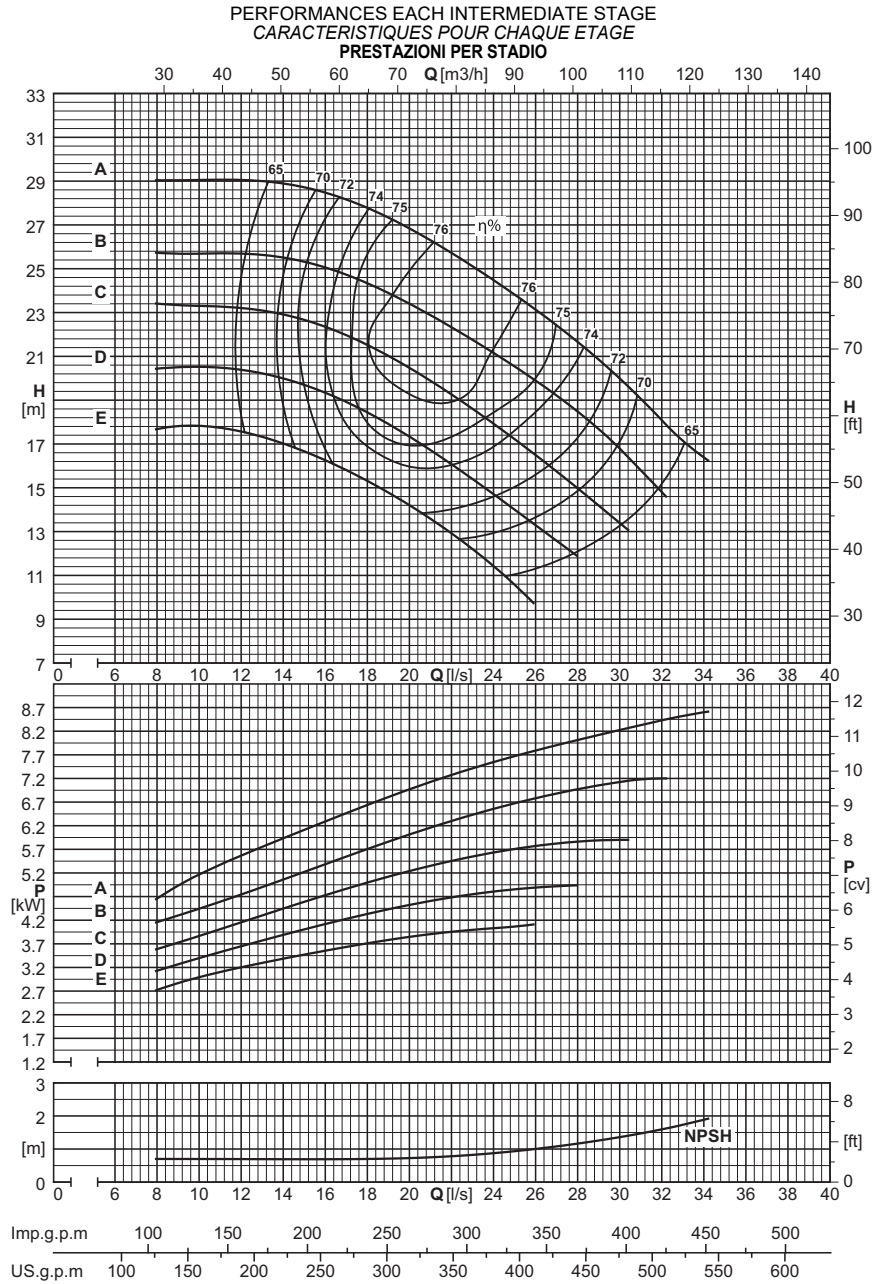

Dna x Dnm		Impeller type Roue type Girante tipo	[l/s]	0	14	15	16	17	18	19	20	21	22	23	24	25	26	27	28	29	30	31	32	33	34		
			[m ³ /h]	0	50,4	54	57,6	61,2	64,8	68,4	72	75,6	79,2	82,8	86,4	90	93,6	97,2	100,8	104,4	108	111,6	115,2	118,8	122,4		
			[l/min]	0	840	900	960	1020	1080	1140	1200	1260	1320	1380	1440	1500	1560	1620	1680	1740	1800	1860	1920	1980	2040		
PMA(S/H)100/1																											
150x100	E	[m]	17,5	16,5	16,5	16,5	16,5	15,5	15	14	13,5	13	12	11,5	10,5												
150x100	E	[kW]		3,4	3,5	3,5	3,6	3,7	3,7	3,8	3,9	3,9	4	4	4,1												
150x100	D	[m]	19,5	20,5	20	19,5	19	18,5	17,5	17	16,5	16,5	15,5	14,5	14,5	13,5	12,5	12									
150x100	D	[kW]		3,8	4	4,1	4,2	4,3	4,5	4,6	4,7	4,7	4,8	4,8	4,9	4,9	4,9	4,9									
150x100	C	[m]	23	22,5	22,5	22,5	22,5	22	21	20,5	20	19,5	18,5	18	17	16,5	16	15,5	14	13,5	13						
150x100	C	[kW]		4,5	4,6	4,7	4,8	4,9	5,2	5,3	5,4	5,4	5,5	5,6	5,8	5,8	5,8	5,8	5,8	5,8	6	6					
150x100	B	[m]	26,5	26	26	24,5	24,5	24,5	24	23,5	22,5	22,5	22	21,5	20,5	20	19	18,5	18	17	16	14,5	14				
150x100	B	[kW]		5	5,1	5,5	5,6	5,7	5,8	6,1	6,2	6,3	6,4	6,5	6,7	6,8	6,9	6,9	7,2	7,2	7,2	7,2	7,4				
150x100	A	[m]	29,5	28	28,5	29	30	27,5	27,5	27	26	25,5	25	24,5	23,5	23	22,5	21,5	21	20	19	18,5	17	16,5			
150x100	A	[kW]		6,1	6,1	6,2	6,3	6,7	6,8	6,9	7,2	7,3	7,4	7,4	7,8	7,8	7,9	7,9	8,2	8,2	8,3	8,5	8,6	8,6			
NPSH																											
		[m]		0,7	0,7	0,7	0,7	0,7	0,7	0,7	0,8	0,8	0,8	0,9	0,9	1	1,1	1,2	1,3	1,4	1,5	1,6	1,7	1,9			

Overall dimensions and weights
 Dimensions d'encombrement et poids
 Dimensioni di ingombro e pesi

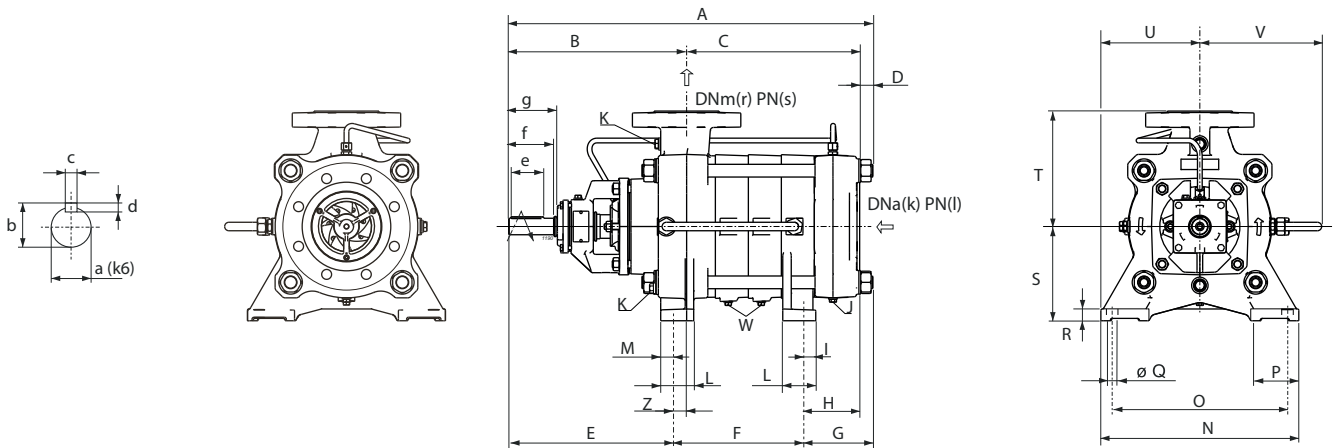

Series Série Serie	Type Type Tipo	A	B	C	D	E	F	G	H	S	T	U	V	Z	Weight Poids Peso
		[mm]													
PMA(S)	100/2	672	395	247	30	362	149	161	131	225	270	230	273	33	183
PMA(S)	100/3	747	395	322	30	362	224	161	131	225	270	230	273	33	208
PMA(S/H)	100/4	822	395	397	30	362	299	161	131	225	270	230	273	33	234
PMA(S/H)	100/5	897	395	472	30	362	374	161	131	225	270	230	273	33	259
PMA(S/H)	100/6	972	395	547	30	362	449	161	131	225	270	230	273	33	284
PMA(S/H)	100/7	1047	395	622	30	362	524	161	131	225	270	230	273	33	309
PMA(S/H)	100/8	1122	395	697	30	362	599	161	131	225	270	230	273	33	334
PMA(S/H)	100/9	1197	395	772	30	362	674	161	131	225	270	230	273	33	359
PMA(S/H)	100/10	1272	395	847	30	362	749	161	131	225	270	230	273	33	384
PMA(S/H)	100/11	1347	395	922	30	362	824	161	131	225	270	230	273	33	410

Foot dimensions Dimensions des pieds Dimensioni dei piedi							
I	L	M	N	O	P	Q	R
[mm]							
32	85	32	460	400	117	24,5	30

Shaft projection Saille d'arbre Sporgenza d'albero						
a	b	c	d	e	f	g
[mm]						
35	38	10	8	70	95	101

Type Type Tipo	Flanges Brides Flange			
	(k) DNa	(l) PN	(r) DNm	(s) PN
	[mm]	[bar]	[mm]	[bar]
PMA	150	25	100	40
PMAS	150	25	100	63
PMAH	150	40	100	100

Plugs Bouchons Tappi		
J	K	W
G 1/4	G 1/2	G 1/4

COUPLINGS WITH STANDARDIZED ENCLOSED ELECTRIC MOTORS
 ACCOUPLEMENTS AVEC MOTEURS ÉLECTRIQUES FERMÉS NORMALISÉS
 ACCOPPIAMENTI CON MOTORI ELETTRICI CHIUSI NORMALIZZATI

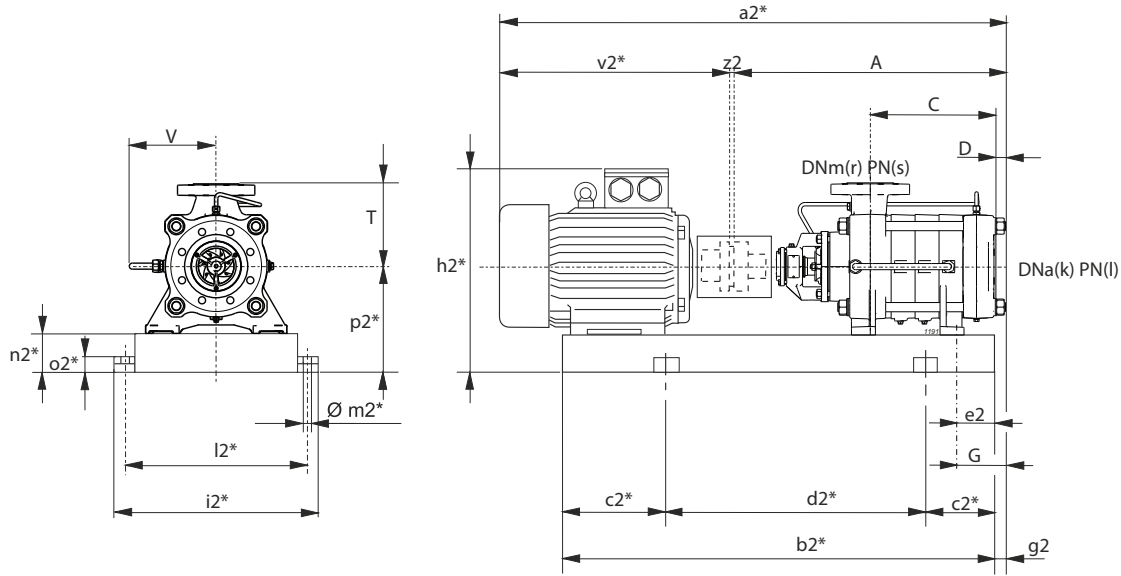

$g2 = G - e2$

* Valori indicativi in funzione della marca di motore utilizzato
 Indicative values according to the type of motor installed

Pump Pompe Pompa		Motor Moteur Motore		BGAMA	A	C	D	G	T	V	a2*	b2*	c2*	d2*	e2	h2*	i2*	k	l	l2*	m2*	n2*	o2*	p2*	r	s	v2*	z2	Weight Poids Peso		
Series Série Serie	Type Type Tipo	[kW]	Size Taille Grand.	Type Type Tipo	[mm]																										[kg]
PMA(S)	100/2	45	225M	775/FN	672	247	30	161	270	273	1451	1213	200	813	50	675	590	150	(1)	540	20	120	42	345	100	(2)	775	4	576		
PMA(S)	/2	55	250M	776/GQ	672	247	30	161	270	273	1546	1305	200	905	70	745	635	150	(1)	585	20	120	42	370	100	(2)	870	4	672		
PMA(S)	/2	75	280S	777/HQ	672	247	30	161	270	273	1676	1352	250	852	70	815	695	150	(1)	645	20	140	42	420	100	(2)	1000	4	858		
PMA(S)	/2	90	280M	778/HQ	672	247	30	161	270	273	1727	1403	250	903	70	815	695	150	(1)	645	20	140	42	420	100	(2)	1051	4	986		
PMA(S)	100/3	75	280S	779/HQ	747	322	30	161	270	273	1751	1427	250	927	70	815	695	150	(1)	645	20	140	42	420	100	(2)	1000	4	885		
PMA(S)	/3	90	280M	780/HQ	747	322	30	161	270	273	1802	1478	250	978	70	815	695	150	(1)	645	20	140	42	420	100	(2)	1051	4	1014		
PMA(S)	/3	110	315S	781/IQ	747	322	30	161	270	273	1932	1554	250	1054	100	1030	780	150	(1)	730	22	160	50	475	100	(2)	1181	4	1372		
PMA(S)	/3	132	315M	782/IQ	747	322	30	161	270	273	2042	1613	250	1113	100	1030	780	150	(1)	730	22	160	50	475	100	(2)	1291	4	1446		
PMA(S/H)	100/4	90	280M	783/HQ	822	397	30	161	270	273	1877	1553	250	1053	70	815	695	150	(1)	645	20	140	42	420	100	(2)	1051	4	1042		
PMA(S/H)	/4	110	315S	784/IQ	822	397	30	161	270	273	2007	1629	250	1129	100	1030	780	150	(1)	730	22	160	50	475	100	(2)	1181	4	1401		
PMA(S/H)	/4	132	315M	785/IQ	822	397	30	161	270	273	2117	1688	300	1088	100	1030	780	150	(1)	730	22	160	50	475	100	(2)	1291	4	1475		
PMA(S/H)	/4	160	315L	786/LQ	822	397	30	161	270	273	2117	1739	300	1139	100	1030	780	150	(1)	730	22	160	50	475	100	(2)	1291	4	1560		
PMA(S/H)	/4	200	315L	786/IE4/LQ	822	397	30	161	270	273	2207	1829	300	1229	198	1030	780	150	(1)	730	22	160	50	475	100	(2)	1381	4	1671		
PMA(S/H)	100/5	110	315S	787/IQ	897	472	30	161	270	273	2082	1704	300	1104	100	1030	780	150	(1)	730	22	160	50	475	100	(2)	1181	4	1429		
PMA(S/H)	/5	132	315M	788/IQ	897	472	30	161	270	273	2192	1763	300	1163	100	1030	780	150	(1)	730	22	160	50	475	100	(2)	1291	4	1503		
PMA(S/H)	/5	160	315L	789/LQ	897	472	30	161	270	273	2192	1814	300	1214	100	1030	780	150	(1)	730	22	160	50	475	100	(2)	1291	4	1587		
PMA(S/H)	/5	200	315L	789/IE4/LQ	897	472	30	161	270	273	2282	1904	300	1304	198	1030	780	150	(1)	730	22	160	50	475	100	(2)	1381	4	1699		
PMA(S/H)	/5	250	355M	790/LQ	897	472	30	161	270	273	2427	1868	300	1268	100	1136	880	150	(1)	830	22	180	50	535	100	(2)	1526	4	2091		
PMA(S/H)	100/6	132	315M	791/IQ	972	547	30	161	270	273	2267	1838	300	1238	100	1030	780	150	(1)	730	22	160	50	475	100	(2)	1291	4	1531		
PMA(S/H)	/6	160	315L	792/LQ	972	547	30	161	270	273	2267	1889	300	1289	100	1030	780	150	(1)	730	22	160	50	475	100	(2)	1291	4	1615		
PMA(S/H)	/6	200	315L	792/IE4/LQ	972	547	30	161	270	273	2357	1979	350	1279	198	1030	780	150	(1)	730	22	160	50	475	100	(2)	1381	4	1726		
PMA(S/H)	/6	250	355M	793/LQ	972	547	30	161	270	273	2502	1943	300	1343	100	1136	880	150	(1)	830	22	180	50	535	100	(2)	1526	4	2122		
PMA(S/H)	/6	315	355L	793/MQ	972	547	30	161	270	273	2502	2013	350	1313	100	1136	880	150	(1)	830	22	180	50	535	100	(2)	1526	4	2251		
PMA(S/H)	100/7	160	315L	798/IQ	1047	622	30	161	270	273	2342	1964	350	1264	100	1030	780	150	(1)	730	22	160	50	475	100	(2)	1291	4	1638		
PMA(S/H)	/7	200	315L	794/IE4/LQ	1047	622	30	161	270	273	2432	2054	350	1354	198	1030	780	150	(1)	730	22	160	50	475	100	(2)	1381	4	1754		
PMA(S/H)	/7	250	355M	795/LQ	1047	622	30	161	270	273	2577	2018	350	1318	100	1136	880	150	(1)	830	22	180	50	535	100	(2)	1526	4	2150		
PMA(S/H)	/7	315	355L	795/MQ	1047	622	30	161	270	273	2577	2088	350	1388	100	1136	880	150	(1)	830	22	180	50	535	100	(2)	1526	4	2279		
PMA(S/H)	100/8	160	315L	799/IQ	1122	697	30	161	270	273	2417	2039	350	1339	100	1030	780	150	(1)	730	22	160	50	475	100	(2)	1291	4	1696		
PMA(S/H)	/8	200	315L	796/IE4/LQ	1122	697	30	161	270	273	2507	2039	350	1339	100	1030	780	150	(1)	730	22	160	50	475	100	(2)	1381	4	1701		
PMA(S/H)	/8	250	355M	797/LQ	1122	697	30	161	270	273	2652	2093	350	1393	100	1136	880	150	(1)	830	22	180	50	535	100	(2)	1526	4	2179		
PMA(S/H)	/8	315	355L	797/MQ	1122	697	30	161	270	273	2652	2163	350	1463	100	1136	880	150	(1)	830	22	180	50	535	100	(2)	1526	4	2308		
PMA(S/H)	/8	355	355L	797/MQ	1122	697	30	161	270	273	2652	2163	350	1463	100	1136	880	150	(1)	830	22	180	50	535	100	(2)	1526	4	2308		

BGAMA = Base and coupling

* = Indicative values according to the type of motor installed

○ Motor in IE4 efficiency class according to EU REGULATION 2019/1781. Available in other efficiency classes for non-EU markets.

(1) PMA=25 bar PMAS=25 bar PMAH=40 bar

(2) PMA=40 bar PMAS=63 bar PMAH=100 bar

BGAMA = Socle et accouplement

* = Valeurs indicatives en fonction de la marque du moteur utilisé

○ Moteur en classe de rendement IE4 conformément au RÈGLEMENT UE2019/1781. Disponible en différentes classes de rendement pour les marchés hors UE.

(1) PMA=25 bar PMAS=25 bar PMAH=40 bar

(2) PMA=40 bar PMAS=63 bar PMAH=100 bar

BGAMA = Base giunto e coprigiunto

* = Valori indicativi in funzione della marca di motore utilizzato.

○ Motore in classe di efficienza IE4 in conformità al REGOLAMENTO UE2019/1781. Disponibili in altre classi di efficienza per mercati extra UE.

(1) PMA=25 bar PMAS=25 bar PMAH=40 bar

(2) PMA=40 bar PMAS=63 bar PMAH=100 bar

Selection - dimensions and weights for base mounted electric pumps
Sélection - dimensions et poids des électropompes sur socle
 Selezione - dimensioni e pesi elettropompe su base

COUPLINGS WITH STANDARDIZED ENCLOSED ELECTRIC MOTORS
ACCOUPEMENTS AVEC MOTEURS ÉLECTRIQUES FERMÉS NORMALISÉS
 ACCOPIAMENTI CON MOTORI ELETTRICI CHIUSI NORMALIZZATI

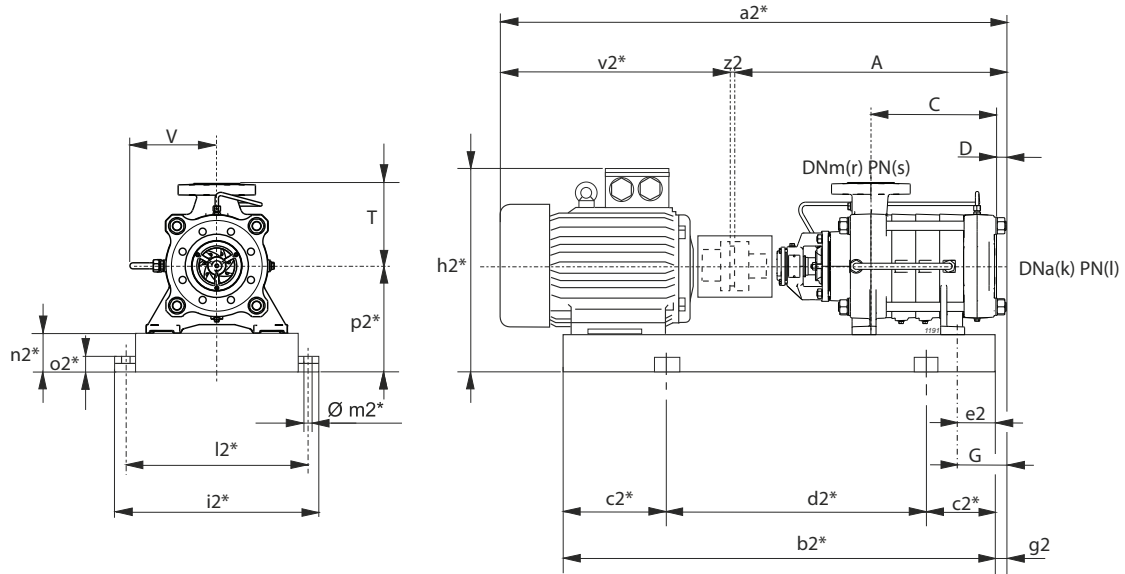

$g2 = G - e2$

* Valori indicativi in funzione della marca di motore utilizzato
Indicatives values according to the type of motor installed

Pump Pompe Pompa		Motor Moteur Motore		BGAMA	A	C	D	G	T	V	a2*	b2*	c2*	d2*	e2	h2*	i2*	k	l	l2*	m2*	n2*	o2*	p2*	r	s	v2*	z2	Weight Poids Peso
Series Série Serie	Type Type Tipo	[kW]	Size Taille Grand.	Type Type Tipo	[mm]																								[kg]
PMA(H)	100/9	200	315L	1255/IE4/LQ	1197	772	30	161	270	273	2582	2204	350	1504	198	1030	780	150	(1)	730	22	160	50	475	100	(2)	1381	4	1809
PMA(H)	/9	280	355L	1256/LQ	1197	772	30	161	270	273	2727	2238	350	1538	100	1136	880	150	(1)	830	22	180	50	535	100	(2)	1526	4	2332
PMA(H)	/9	315	355L	1256/MQ	1197	772	30	161	270	273	2727	2238	350	1538	100	1136	880	150	(1)	830	22	180	50	535	100	(2)	1526	4	2326
PMA(H)	/9	355	355L	1256/MQ	1197	772	30	161	270	273	2727	2238	350	1538	100	1136	880	150	(1)	830	22	180	50	535	100	(2)	1526	4	2326
PMA(H)	100/10	200	315L	1257/IE4/LQ	1272	847	30	161	270	273	2657	2279	400	1479	198	1030	780	150	(1)	730	22	160	50	475	100	(2)	1381	4	1836
PMA(H)	/10	315	355L	1258/MQ	1272	847	30	161	270	273	2802	2313	400	1513	100	1136	880	150	(1)	830	22	180	50	535	100	(2)	1526	4	2354
PMA(H)	/10	355	355L	1258/MQ	1272	847	30	161	270	273	2802	2313	400	1513	100	1136	880	150	(1)	830	22	180	50	535	100	(2)	1526	4	2354
PMA(H)	100/11	280	355L	1259/LQ	1347	922	30	161	270	273	2877	2388	400	1588	100	1136	880	150	(1)	830	22	180	50	535	100	(2)	1526	4	2389
PMA(H)	/11	315	355L	1259/MQ	1347	922	30	161	270	273	2877	2388	400	1588	100	1136	880	150	(1)	830	22	180	50	535	100	(2)	1526	4	2383
PMA(H)	/11	355	355L	1259/MQ	1347	922	30	161	270	273	2877	2388	400	1588	100	1136	880	150	(1)	830	22	180	50	535	100	(2)	1526	4	2383

BGAMA = Base and coupling

* = Indicatives values according to the type of motor installed

○ Motor in IE4 efficiency class according to EU REGULATION 2019/1781. Available in other efficiency classes for non-EU markets.

- (1) PMA=25 bar PMAS=25 bar PMAH=40 bar
 (2) PMA=40 bar PMAS=63 bar PMAH=100 bar

BGAMA = Socle et accouplement

* = Valeurs indicatives en fonction de la marque du moteur utilisé

○ Moteur en classe de rendement IE4 conformément au RÈGLEMENT UE2019/1781. Disponibilité en différentes classes de rendement pour les marchés hors UE.

- (1) PMA=25 bar PMAS=25 bar PMAH=40 bar
 (2) PMA=40 bar PMAS=63 bar PMAH=100 bar

BGAMA = Base giunto e coprigiunto

* = Valori indicativi in funzione della marca di motore utilizzato.

○ Motore in classe di efficienza IE4 in conformità al REGOLAMENTO UE2019/1781. Disponibili in altre classi di efficienza per mercati extra UE.

- (1) PMA=25 bar PMAS=25 bar PMAH=40 bar
 (2) PMA=40 bar PMAS=63 bar PMAH=100 bar

Selection - dimensions and weights for base mounted electric pumps
 Sélection - dimensions et poids des électropompes sur socle
 Selezione - dimensioni e pesi elettropompe su base

COUPLINGS WITH STANDARDIZED ENCLOSED ELECTRIC MOTORS
 ACCOUPLEMENTS AVEC MOTEURS ÉLECTRIQUES FERMÉS NORMALISÉS
 ACCOPIAMENTI CON MOTORI ELETTRICI CHIUSI NORMALIZZATI

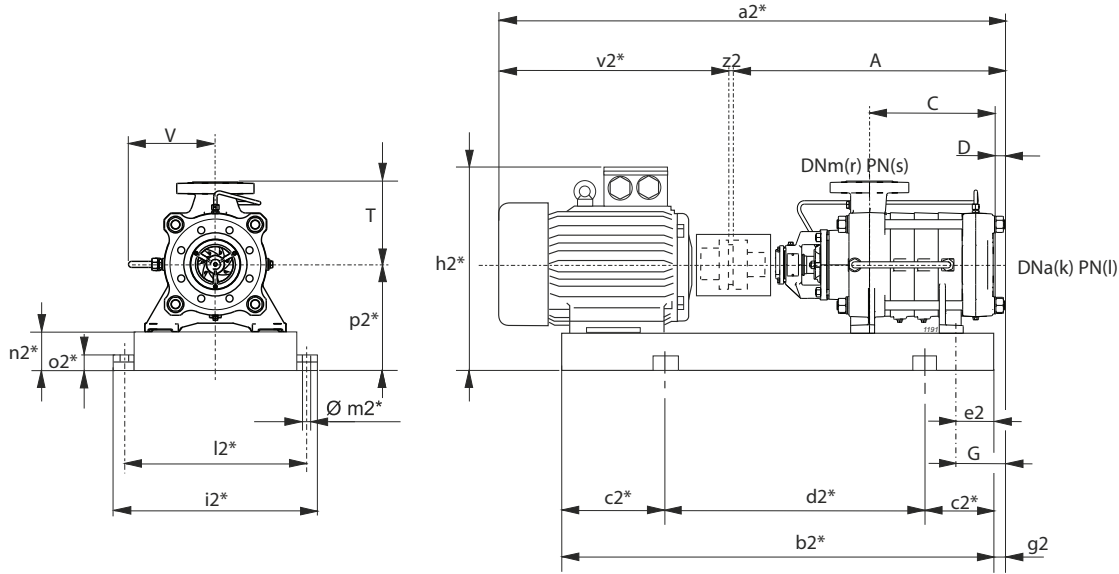

g2 = G-e2

* Valori indicativi in funzione della marca di motore utilizzato
 Indicatives values according to the type of motor installed

Pump Pompe		Motor Moteur		BGAMA	A	C	D	G	T	V	a2*	b2*	c2*	d2*	e2	h2*	i2*	k	l	l2*	m2*	n2*	o2*	p2*	r	s	v2*	z2	Weight Poids Peso	
Series Série Serie	Type Type Tipo	[kW]	Size Taille Grand.	Type Type Tipo	[mm]																									[kg]
PMA(S)	100/2	5,5	132S	730/CN	672	247	30	161	270	273	1131	916	150	616	50	537	590	150	(1)	540	20	120	42	345	100	(2)	455	4	288	
PMA(S)	/2	7,5	132M	731/DN	672	247	30	161	270	273	1166	954	150	654	50	537	590	150	(1)	540	20	120	42	345	100	(2)	490	4	299	
PMA(S)	/2	11	160M	732/EN	672	247	30	161	270	273	1303	1060	200	660	50	596	590	150	(1)	540	20	120	42	345	100	(2)	627	4	396	
PMA(S)	100/3	7,5	132M	733/DN	747	322	30	161	270	273	1241	1029	150	729	50	537	590	150	(1)	540	20	120	42	345	100	(2)	490	4	326	
PMA(S)	/3	11	160M	734/EN	747	322	30	161	270	273	1378	1135	200	735	50	596	590	150	(1)	540	20	120	42	345	100	(2)	627	4	423	
PMA(S)	/3	15	160L	735/EN	747	322	30	161	270	273	1378	1179	200	779	50	596	590	150	(1)	540	20	120	42	345	100	(2)	627	4	436	
PMA(S)	/3	18,5	180M	736/FN	747	322	30	161	270	273	1416	1189	200	789	50	615	590	150	(1)	540	20	120	42	345	100	(2)	665	4	458	
PMA(S/H)	100/4	11	160M	737/EN	822	397	30	161	270	273	1453	1210	200	810	50	596	590	150	(1)	540	20	120	42	345	100	(2)	627	4	451	
PMA(S/H)	/4	15	160L	738/EN	822	397	30	161	270	273	1453	1254	200	854	50	596	590	150	(1)	540	20	120	42	345	100	(2)	627	4	464	
PMA(S/H)	/4	18,5	180M	739/FN	822	397	30	161	270	273	1491	1264	200	864	50	615	590	150	(1)	540	20	120	42	345	100	(2)	665	4	491	
PMA(S/H)	/4	22	180L	740/FN	822	397	30	161	270	273	1531	1302	200	902	50	615	590	150	(1)	540	20	120	42	345	100	(2)	705	4	512	
PMA(S/H)	100/5	15	160L	741/EN	897	472	30	161	270	273	1528	1329	200	929	50	596	590	150	(1)	540	20	120	42	345	100	(2)	627	4	491	
PMA(S/H)	/5	18,5	180M	742/FN	897	472	30	161	270	273	1566	1339	200	939	50	615	590	150	(1)	540	20	120	42	345	100	(2)	665	4	518	
PMA(S/H)	/5	22	180L	743/FN	897	472	30	161	270	273	1606	1377	250	877	50	615	590	150	(1)	540	20	120	42	345	100	(2)	705	4	539	
PMA(S/H)	/5	30	200L	744/GN	897	472	30	161	270	273	1659	1412	250	912	50	645	590	150	(1)	540	20	120	42	345	100	(2)	758	4	603	
PMA(S/H)	100/6	15	160L	745/EN	972	547	30	161	270	273	1603	1404	250	904	50	596	590	150	(1)	540	20	120	42	345	100	(2)	627	4	518	
PMA(S/H)	/6	18,5	180M	746/FN	972	547	30	161	270	273	1641	1414	250	914	50	615	590	150	(1)	540	20	120	42	345	100	(2)	665	4	545	
PMA(S/H)	/6	22	180L	747/FN	972	547	30	161	270	273	1681	1452	250	952	50	615	590	150	(1)	540	20	120	42	345	100	(2)	705	4	566	
PMA(S/H)	/6	30	200L	748/GN	972	547	30	161	270	273	1734	1487	250	987	50	645	590	150	(1)	540	20	120	42	345	100	(2)	758	4	630	
PMA(S/H)	/6	37	225S	749/HQ	972	547	30	161	270	273	1769	1518	250	1018	50	675	590	150	(1)	540	20	120	42	345	100	(2)	793	4	674	
PMA(S/H)	100/7	18,5	180M	750/FN	1047	622	30	161	270	273	1716	1489	250	989	50	615	590	150	(1)	540	20	120	42	345	100	(2)	665	4	572	
PMA(S/H)	/7	22	180L	751/FN	1047	622	30	161	270	273	1756	1527	250	1027	50	615	590	150	(1)	540	20	120	42	345	100	(2)	705	4	593	
PMA(S/H)	/7	30	200L	752/GN	1047	622	30	161	270	273	1809	1562	250	1062	50	645	590	150	(1)	540	20	120	42	345	100	(2)	758	4	657	
PMA(S/H)	/7	37	225S	753/HQ	1047	622	30	161	270	273	1844	1593	250	1093	50	675	590	150	(1)	540	20	120	42	345	100	(2)	793	4	701	
PMA(S/H)	100/8	22	180L	754/FN	1122	697	30	161	270	273	1831	1602	250	1102	50	615	590	150	(1)	540	20	120	42	345	100	(2)	705	4	620	
PMA(S/H)	/8	30	200L	755/GN	1122	697	30	161	270	273	1884	1637	250	1137	50	645	590	150	(1)	540	20	120	42	345	100	(2)	758	4	684	
PMA(S/H)	/8	37	225S	756/HQ	1122	697	30	161	270	273	1919	1668	300	1068	50	675	590	150	(1)	540	20	120	42	345	100	(2)	793	4	727	
PMA(S/H)	/8	45	225M	757/HQ	1122	697	30	161	270	273	1944	1693	300	1093	50	675	590	150	(1)	540	20	120	42	345	100	(2)	818	4	771	
PMA(S/H)	100/9	30	200L	758/GN	1197	772	30	161	270	273	1959	1712	300	1112	50	645	590	150	(1)	540	20	120	42	345	100	(2)	758	4	711	
PMA(S/H)	/9	37	225S	759/HQ	1197	772	30	161	270	273	1994	1743	300	1143	50	675	590	150	(1)	540	20	120	42	345	100	(2)	793	4	755	
PMA(S/H)	/9	45	225M	760/HQ	1197	772	30	161	270	273	2019	1768	300	1168	50	675	590	150	(1)	540	20	120	42	345	100	(2)	818	4	798	
PMA(S/H)	/9	55	250M	761/IQ	1197	772	30	161	270	273	2081	1830	300	1230	70	745	635	150	(1)	585	20	120	42	370	100	(2)	880	4	927	
PMA(S/H)	100/10	30	200L	762/GN	1272	847	30	161	270	273	2034	1787	300	1187	50	645	590	150	(1)	540	20	120	42	345	100	(2)	758	4	738	
PMA(S/H)	/10	37	225S	763/HQ	1272	847	30	161	270	273	2069	1818	300	1218	50	675	590	150	(1)	540	20	120	42	345	100	(2)	793	4	782	
PMA(S/H)	/10	45	225M	764/HQ	1272	847	30	161	270	273	2094	1843	300	1243	50	675	590	150	(1)	540	20	120	42	345	100	(2)	818	4	825	
PMA(S/H)	/10	55	250M	765/IQ	1272	847	30	161	270	273	2156	1905	300	1305	70	745	635	150	(1)	585	20	120	42	370	100	(2)	880	4	954	

BGAMA = Base and coupling

BGAMA = Socle et accouplement

BGAMA = Base giunto e coprigiunto

* = Indicatives values according to the type of motor installed

* = Valeurs indicatives en fonction de la marque du moteur utilisé

* = Valori indicativi in funzione della marca di motore utilizzato.

(1) PMA=25 bar PMAS=25 bar PMAH=40 bar

(1) PMA=25 bar PMAS=25 bar PMAH=40 bar

(1) PMA=25 bar PMAS=25 bar PMAH=40 bar

(2) PMA=40 bar PMAS=63 bar PMAH=100 bar

(2) PMA=40 bar PMAS=63 bar PMAH=100 bar

(2) PMA=40 bar PMAS=63 bar PMAH=100 bar

Selection - dimensions and weights for base mounted electric pumps
Sélection - dimensions et poids des électropompes sur socle
 Selezione - dimensioni e pesi elettropompe su base

COUPLINGS WITH STANDARDIZED ENCLOSED ELECTRIC MOTORS
 ACCOUPLEMENTS AVEC MOTEURS ÉLECTRIQUES FERMÉS NORMALISÉS
 ACCOPIAMENTI CON MOTORI ELETTRICI CHIUSI NORMALIZZATI

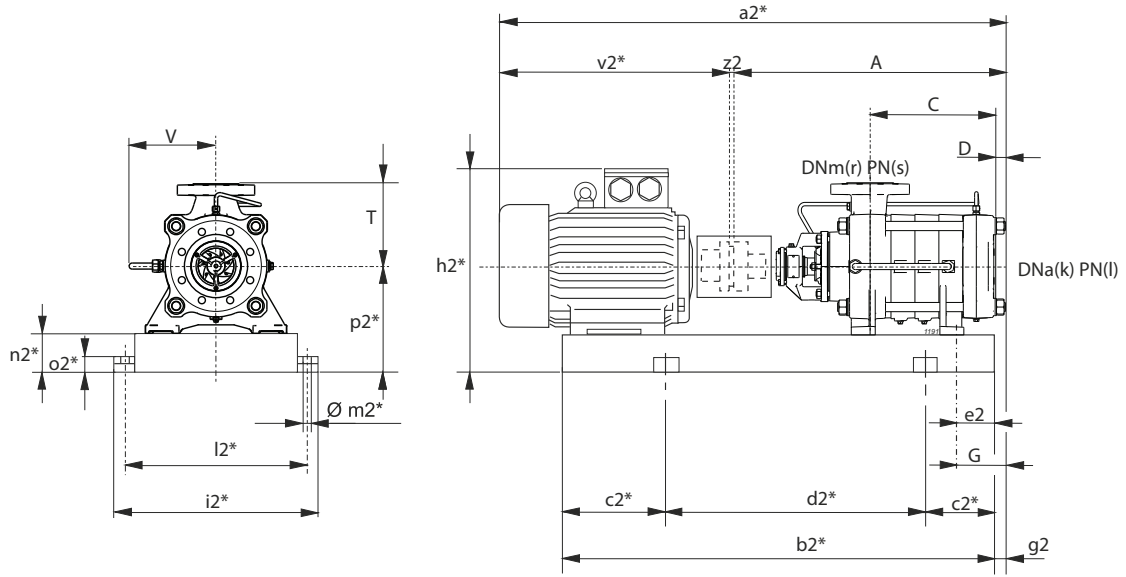

$g2 = G - e2$

* Valori indicativi in funzione della marca di motore utilizzato
Indicatives values according to the type of motor installed

Pump Pompe Pompa		Motor Moteur Motore		BGAMA	A	C	D	G	T	V	a2*	b2*	c2*	d2*	e2	h2*	i2*	k	l	l2*	m2*	n2*	o2*	p2*	r	s	v2*	z2	Weight Poids Peso
Series Série Serie	Type Type Tipo	[kW]	Size Taille Grand.	Type Type Tipo	[mm]																								[kg]
PMA(S/H)	100/11	30	200L	766/GN	1347	922	30	161	270	273	2109	1862	300	1262	50	645	590	150	(1)	540	20	120	42	345	100	(2)	758	4	766
PMA(S/H)	/11	37	225S	767/HQ	1347	922	30	161	270	273	2144	1893	300	1293	50	675	590	150	(1)	540	20	120	42	345	100	(2)	793	4	810
PMA(S/H)	/11	45	225M	768/HQ	1347	922	30	161	270	273	2169	1918	300	1318	50	675	590	150	(1)	540	20	120	42	345	100	(2)	818	4	853
PMA(S/H)	/11	55	250M	769/IQ	1347	922	30	161	270	273	2231	1980	350	1280	70	745	635	150	(1)	585	20	120	42	370	100	(2)	880	4	982
PMA(S/H)	/11	75	280S	770/IQ	1347	922	30	161	270	273	2364	2027	350	1327	70	815	695	150	(1)	645	20	140	42	420	100	(2)	1013	4	1149

BGAMA = Base and coupling

* = Indicatives values according to the type of motor installed

(1) PMA=25 bar PMAS=25 bar PMAH=40 bar

(2) PMA=40 bar PMAS=63 bar PMAH=100 bar

BGAMA = Socle et accouplement

* = Valeurs indicatives en fonction de la marque du moteur utilisé

(1) PMA=25 bar PMAS=25 bar PMAH=40 bar

(2) PMA=40 bar PMAS=63 bar PMAH=100 bar

BGAMA = Base giunto e coprigiunto

* = Valori indicativi in funzione della marca di motore utilizzato.

(1) PMA=25 bar PMAS=25 bar PMAH=40 bar

(2) PMA=40 bar PMAS=63 bar PMAH=100 bar