

Electric pump type <i>Electropompe type</i> Elettropompa tipo	Impeller type <i>Roue type</i> Girante tipo	Capacity <i>Debit</i> Portata																	
		[l/m]	300	360	420	480	540	600	1200	1800	2400	3000	3600	4200	4800	5400	6000	7200	8040
		[m³/h]	18	22	25	29	32	36	72	108	144	180	216	252	288	324	360	432	482
[l/s]	5	6	7	8	9	10	20	30	40	50	60	70	80	90	100	120	134		
		Total manometric head <i>Hauteur manometrique totale</i> Prevalenza manometrica totale																	
SCC-2-125-350	A	[m]				55,6	55,6	55,6	55,6	55,5	55,2	54,8	54	53	51,6	49,8	47,7	42,2	37,4
SCC-2-125-350	B	[m]		40,7	40,7	40,7	40,7	40,6	40,5	40,3	39,9	39,2	38,2	36,6	34,5	31,8	28,3		
SCC-2-125-350	C	[m]	32,8	32,9	32,9	32,9	32,9	32,9	32,8	32,4	31,6	30,2	28,1	25,6	22,6				
NPSH		[m]				1,5	1,5	1,5	1,5	1,5	1,5	1,5	1,6	1,7	2	2,4	2,9	4,6	6,2

Overall dimensions and weights
 Dimensions d'encombrement et poids
 Dimensioni di ingombro e pesi

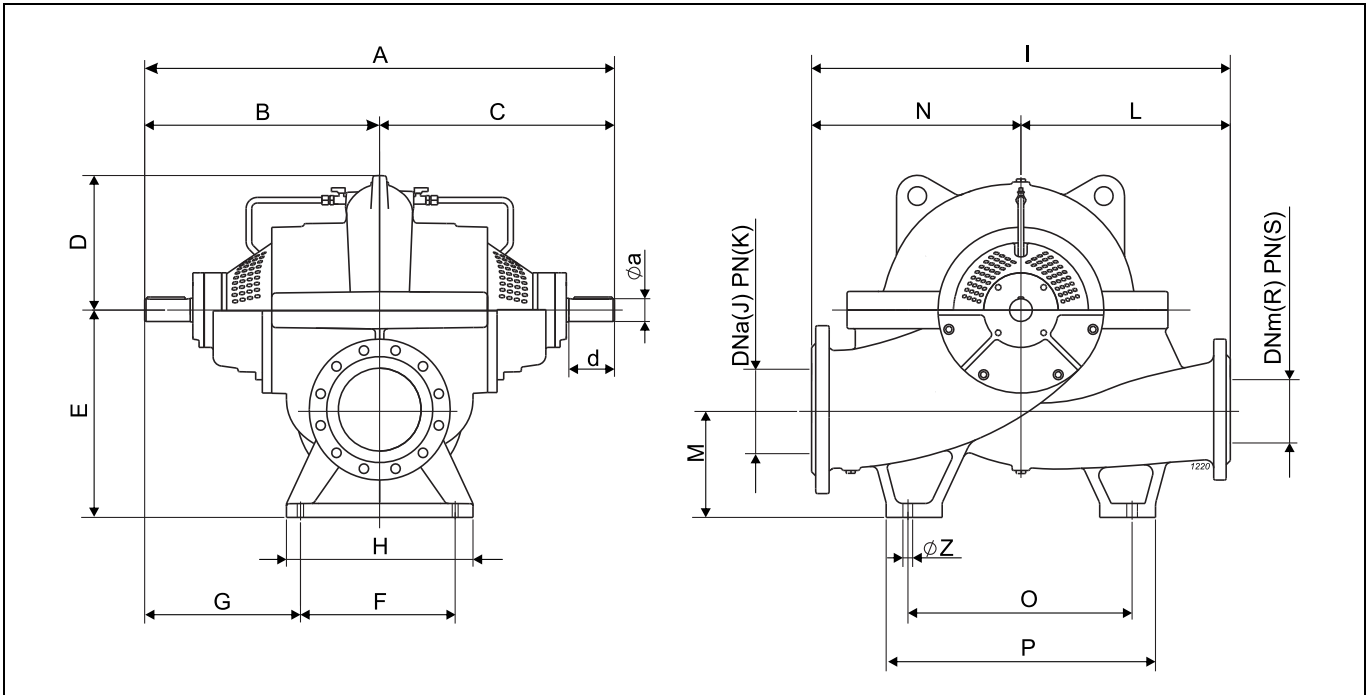

Type Type Tipo	Weight Poids Peso	A	B	C	D	E	F	G	H	I	J	K	L	M	N	O	P	R	S	Z	a	d
		[mm]																				
SCC-2-65-250	157	796	398	398	210	300	230	283	300	600	100	16	280	160	320	380	467	65	16	20	35	75
SCC-2-80-250	162	796	398	398	226	300	233	280	303	599	125	16	280	160	319	405	469	80	16	20	35	75
SCC-2-80-315	200	796	398	398	270	300	225	283,5	300	660	125	16	300	160	360	400	488	80	16	20	35	75
SCC-2-100-250	223	895	447,5	447,5	234	355	281	307	340	670	150	16	310	185	360	400	483	100	16	20	42	90
SCC-2-100-315	230	895	447,5	447,5	252	355	275	309	340	670	150	16	310	185	360	400	485	100	16	20	42	90
SCC-2-100-400	303	895	447,5	447,5	303	355	280	307,5	340	790	150	16	370	185	420	460	560	100	16	20	42	90
SCC-2-125-315	360	1052	526	526	284	400	320	366	380	790	200	16	370	200	420	460	540	125	16	22	55	110
SCC-2-125-350	402	1052	526	526	310	400	320	366	380	920	200	16	450	200	470	540	660	125	16	22	55	110
SCC-2-125-480	400	983	491,5	491,5	308	400	340	321,5	390	900	200	16	450	200	450	560	640	125	16	22	42	90
SCC-2-150-315	400	1052	526	526	319	400	320	366	380	870	200	16	400	200	470	540	643	150	16	22	55	110
SCC-2-150-460	430	1090	545	545	305	400	320	385	380	900	200	16	450	200	450	540	640	150	16	22	55	110
SCC-2-150-600	780	1284	642	642	437	560	320	482	420	1050	250	25	500	260	550	640	640	150	25	22	65	130
SCC-2-200-315	590	1284	642	642	337	500	360	462	420	950	250	16	450	260	500	540	643	200	16	22	65	130
SCC-2-200-430	630	1132	566	566	317	500	360	386	450	1000	250	16	500	260	500	540	650	200	16	24	55	110
SCC-2-200-500	690	1284	642	642	377	560	360	462	420	1050	250	16	500	260	550	620	724	200	16	22	65	130
SCC-2-250-350	680	1284	642	642	399	600	356	464	420	1100	300	16	500	300	600	620	724	250	16	30	65	130
SCC-2-250-450	780	1284	642	642	424	600	360	462	420	1100	300	16	500	300	600	620	720	250	16	23	65	130
SCC-2-250-600	1050	1440	720	720	441	600	405	517,5	485	1200	300	25	550	300	650	620	715	250	25	26	80	170
SCC-2-300-315	700	1284	642	642	400	630	348	468	420	1100	350	16	500	330,03	600	620	700	300	16	24	65	130
SCC-2-300-400	930	1328	664	664	365	630	420	454	520	1190	400	16	560	310	630	680	800	300	16	26	60	140
SCC-2-300-500	1500	1519	759,5	759,5	436	710	410	554,5	520	1450	400	16	750	360	700	700	809	300	16	26	80	170
SCC-2-300-700	1650	1731	865,5	865,5	489	710	410	660,5	520	1550	400	25	800	360	750	720	880	300	25	26,5	100	180
SCC-2-350-350	1120	1544	772	772	449	670	420	562	520	1250	400	16	550	320	700	720	804	350	16	26	75	140
SCC-2-350-400	1410	1545	772,5	772,5	502	800	500	522,5	600	1400	500	16	600	420	800	800	961	350	16	26	75	140
SCC-2-350-500	1435	1509	754,5	754,5	443	800	498	505,5	600	1400	500	16	600	400	800	740	910	350	16	26	80	170
SCC-2-350-700	2000	1731	865,5	865,5	534	850	498	616,5	600	1600	500	25	750	400	850	720	890	350	25	26	100	180

Selection - dimensions and weights for base mounted electric pumps
Sélection - dimensions et poids des électropompes sur socle
 Selezione - dimensioni e pesi elettropompe su base

Couplings with standardized enclosed electric motors
Accouplements avec moteurs électriques fermés normalizzati
 Accoppiamenti con motori elettrici chiusi normalizzati

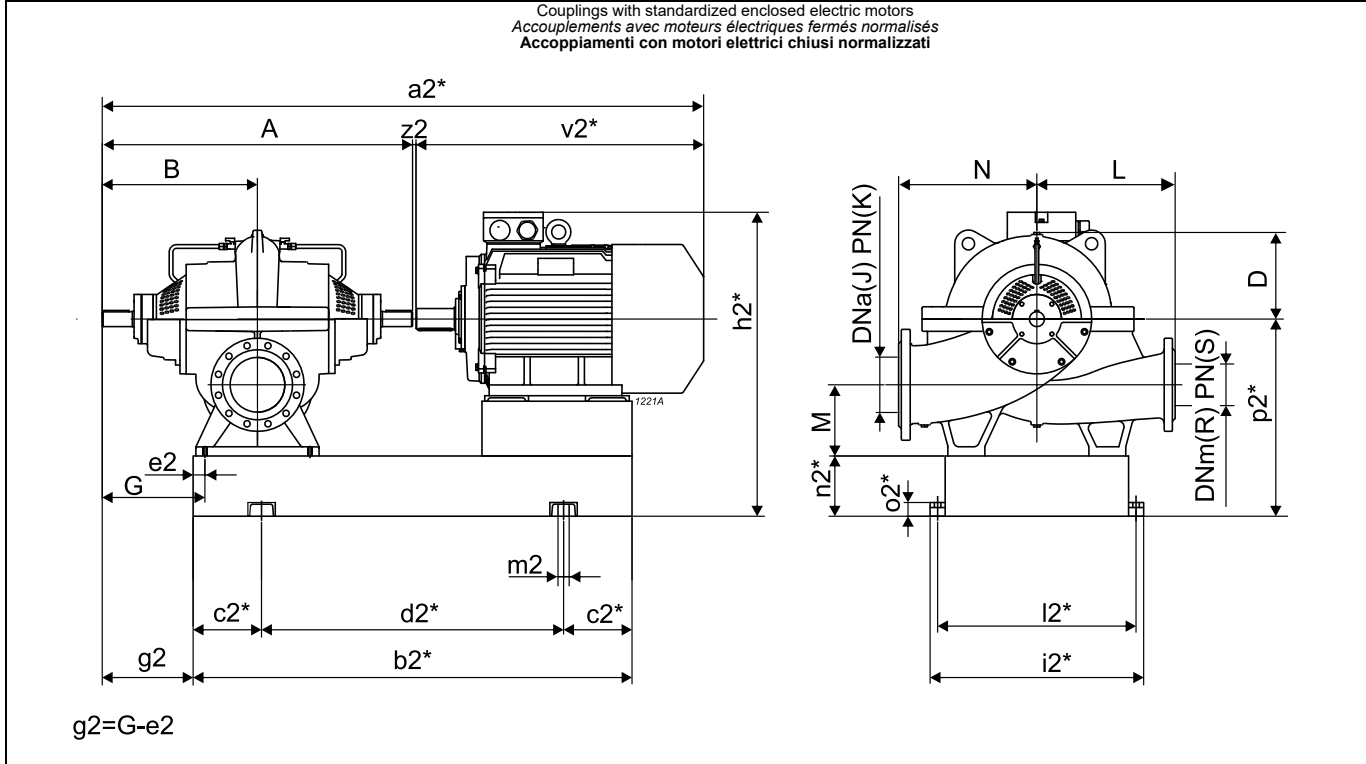

Pump Pompe Pompa	Motor Moteur Motore		Weight Poids Peso	BGAC2	A	B	D	G	J	K	L	M	N	R	S	a2*	b2*	c2*	d2*	e2	h2*	i2*	i2*	m2	n2*	o2*	p2*	v2*	z2		
	Type Type Tipo	[kW]			Size Taille Grand.	[kg]	[mm]																								
SCC-2-125-315	45	225M	901	125-315-45	1052	526	284	366	200	16	370	200	420	125	16	1874	1439	250	939	50	930	670	620	22	200	50	600	818	4		
SCC-2-125-350	30	200L	856	125-350-30	1052	526	310	366	200	16	450	200	470	125	16	1814	1347	200	947	50	900	790	740	22	200	50	600	758	4		
SCC-2-125-350	37	225S	916	125-350-37	1052	526	310	366	200	16	450	200	470	125	16	1849	1414	250	914	50	930	790	740	22	200	50	600	793	4		
SCC-2-125-350	45	225M	961	125-350-45	1052	526	310	366	200	16	450	200	470	125	16	1874	1439	250	939	50	930	790	740	22	200	50	600	818	4		
SCC-2-125-350	55	250M	1074	125-350-55	1052	526	310	366	200	16	450	200	470	125	16	1936	1496	250	996	50	975	790	740	22	200	50	600	880	4		
SCC-2-125-350	75	280S	1209	125-350-75	1052	526	310	366	200	16	450	200	470	125	16	2069	1494	250	994	40	995	790	740	22	200	50	600	1013	4		
SCC-2-125-350	90	280M	1278	125-350-90	1052	526	310	366	200	16	450	200	470	125	16	2120	1578	250	1078	50	995	790	740	22	200	50	600	1064	4		
SCC-2-125-480	45	225M	955	125-480-45	983	491,5	308	321,5	200	16	450	200	450	125	16	1805	1409	250	909	45	930	770	720	22	200	50	600	818	4		
SCC-2-125-480	55	250M	1067	125-480-55	983	491,5	308	321,5	200	16	450	200	450	125	16	1867	1466	250	966	45	975	770	720	22	200	50	600	880	4		
SCC-2-125-480	75	280S	1194	125-480-75	983	491,5	308	321,5	200	16	450	200	450	125	16	2000	1484	250	984	40	995	770	720	22	200	50	600	1013	4		
SCC-2-125-480	90	280M	1262	125-480-90	983	491,5	308	321,5	200	16	450	200	450	125	16	2051	1548	250	1048	45	995	770	720	22	200	50	600	1064	4		
SCC-2-125-480	110	315S	1481	125-480-110	983	491,5	308	321,5	200	16	450	200	450	125	16	2198	1621	250	1121	45	1155	770	720	22	200	50	600	1211	4		
SCC-2-125-480	132	315M	1589	125-480-132	983	491,5	308	321,5	200	16	450	200	450	125	16	2308	1672	300	1072	45	1155	770	720	22	200	50	600	1321	4		
SCC-2-150-315	37	225S	911	150-315-37	1052	526	319	366	200	16	400	200	470	150	16	1849	1414	250	914	50	930	770	720	22	200	50	600	793	4		
SCC-2-150-315	45	225M	956	150-315-45	1052	526	319	366	200	16	400	200	470	150	16	1874	1439	250	939	50	930	770	720	22	200	50	600	818	4		
SCC-2-150-315	55	250M	1069	150-315-55	1052	526	319	366	200	16	400	200	470	150	16	1936	1496	250	996	50	975	770	720	22	200	50	600	880	4		
SCC-2-150-315	75	280S	1302	150-315-75	1052	526	319	366	200	16	400	200	470	150	16	2069	1557	250	1057	50	995	770	720	22	200	50	600	1013	4		
SCC-2-150-315	90	280M	1273	150-315-90	1052	526	319	366	200	16	400	200	470	150	16	2120	1578	250	1078	50	995	770	720	22	200	50	600	1064	4		
SCC-2-150-460	55	250M	1100	150-460-55	1090	545	305	385	200	16	450	200	450	150	16	1974	1516	250	1016	50	975	770	720	22	200	50	600	880	4		
SCC-2-150-460	75	280S	1333	150-460-75	1090	545	305	385	200	16	450	200	450	150	16	2107	1577	250	1077	50	995	770	720	22	200	50	600	1013	4		
SCC-2-150-460	90	280M	1304	150-460-90	1090	545	305	385	200	16	450	200	450	150	16	2158	1598	250	1098	50	995	770	720	22	200	50	600	1064	4		
SCC-2-150-460	110	315S	1614	150-460-110	1090	545	305	385	200	16	450	200	450	150	16	2305	1671	300	1071	50	1155	770	720	22	200	50	600	1211	4		
SCC-2-150-460	132	315M	1735	150-460-132	1090	545	305	385	200	16	450	200	450	150	16	2415	1705	300	1105	40	1155	770	720	22	200	50	600	1321	4		
SCC-2-150-460	160	315L	1841	150-460-160	1090	545	305	385	200	16	450	200	450	150	16	2415	1773	300	1173	50	1155	770	720	22	200	50	600	1321	4		
SCC-2-150-600	90	280M	1728	150-600-90	1284	642	437	482	250	25	500	260	550	150	25	2352	1703	300	1103	70	1175	770	720	22	220	50	780	1064	4		
SCC-2-150-600	110	315S	2028	150-600-110	1284	642	437	482	250	25	500	260	550	150	25	2499	1766	300	1166	70	1335	770	720	22	220	50	780	1211	4		
SCC-2-150-600	132	315M	2154	150-600-132	1284	642	437	482	250	25	500	260	550	150	25	2609	1817	300	1217	70	1335	770	720	22	220	50	780	1321	4		
SCC-2-150-600	160	315L	2263	150-600-160	1284	642	437	482	250	25	500	260	550	150	25	2609	1868	300	1268	70	1335	770	720	22	220	50	780	1321	4		
SCC-2-150-600	200	315L	2397	150-600-200	1284	642	437	482	250	25	500	260	550	150	25	2699	1956	350	1256	70	1335	770	720	22	220	50	780	1411	4		
SCC-2-150-600	250	355M	2780	150-600-250	1284	642	437	482	250	25	500	260	550	150	25	2844	2028	350	1328	70	1381	860	810	22	220	50	780	1556	4		

BGAC2 = Base and coupling
 * = Indicatives values according to the type of motor installed.
 ◦ Motor in IE4 efficiency class according to EU REGULATION 2019/1781. Available in other efficiency classes for non-EU markets.

BGAC2 = Socle et accouplement
 * = Valeurs indicatives en fonction de la marque du moteur utilisé.
 ◦ Moteur en classe de rendement IE4 conformément au RÈGLEMENT UE2019/1781. Disponibilit  en diff rentes classes de rendement pour les march s hors UE.

BGAC2 = Base e giunto
 * = Valori indicativi in funzione della marca di motore utilizzato.
 ◦ Motore in classe di efficienza IE4 in conformit  al REGOLAMENTO UE2019/1781. Disponibili in altre classi di efficienza per mercati extra UE.