

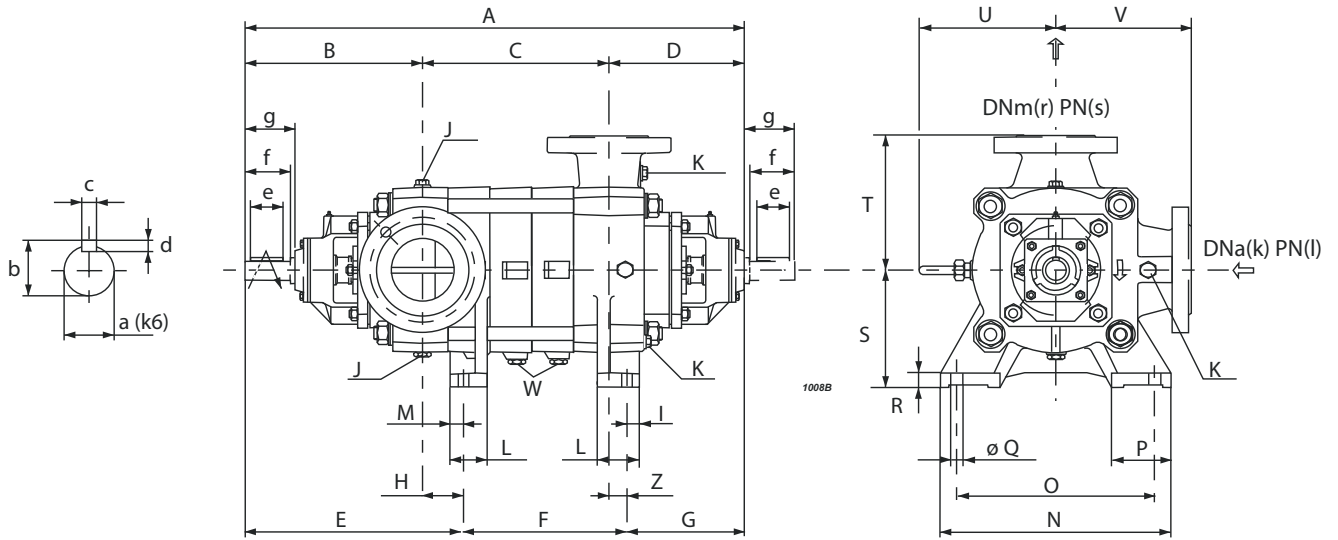

Overall dimensions and weights  
 Dimensions d'encombrement et poids  
 Dimensioni di ingombro e pesi



Series Série Serie	Type Type Tipo	A	B	C	D	E	F	G	H	S	T	U	V	Z	Weight Poids Peso [kg]
		[mm]													
PM(S)	80/2	805	360	171	274	422	138	245	61,5	200	245	258	245	29	179
PM(S)	80/3	875	360	241	274	422	208	245	61,5	200	245	258	245	29	200
PM(S)	80/4	945	360	311	274	422	278	245	61,5	200	245	258	245	29	221
PM(S/H)	80/5	1015	360	381	274	422	348	245	61,5	200	245	258	245	29	242
PM(S/H)	80/6	1085	360	451	274	422	418	245	61,5	200	245	258	245	29	263
PM(S/H)	80/7	1155	360	521	274	422	488	245	61,5	200	245	258	245	29	284
PM(S/H)	80/8	1225	360	591	274	422	558	245	61,5	200	245	258	245	29	305
PM(S/H)	80/9	1295	360	661	274	422	628	245	61,5	200	245	258	245	29	326
PM(S/H)	80/10	1365	360	731	274	422	698	245	61,5	200	245	258	245	29	347
PM(S/H)	80/11	1435	360	801	274	422	768	245	61,5	200	245	258	245	29	368
PM(S/H)	80/12	1505	360	871	274	422	838	245	61,5	200	245	258	245	29	389
PM(S/H)	80/13	1575	360	941	274	422	908	245	61,5	200	245	258	245	29	410
PM(S/H)	80/14	1645	360	1011	274	422	978	245	61,5	200	245	258	245	29	431
PM(S/H)	80/15	1715	360	1081	274	422	1048	245	61,5	200	245	258	245	29	452
PM(S/H)	80/16	1785	360	1151	274	422	1118	245	61,5	200	245	258	245	29	473

Foot dimensions Dimensions des pieds Dimensioni dei piedi								
I	L	M	N	O	P	Q	R	
[mm]								
26	70	25	420	370	102	24	25	

Shaft projection Saille d'arbre Sporgenza d'albero						
a	b	c	d	e	f	g
[mm]						
35	38	10	8	70	90	104

Flanges Brides Flange				
Type Type Tipo	(k) DNa	(l) PN	(r) DNm	(s) PN
	[mm]	[bar]	[mm]	[bar]
PM	100	25	80	40
PMS	100	25	80	63
PMH	100	40	80	100

Plugs Bouchons Tappi		
J	K	W
G1/2	G1/2	G1/4

Selection - dimensions and weights for base mounted electric pumps  
 Sélection - dimensions et poids des électropompes sur socle  
 Selezione - dimensioni e pesi elettropompe su base

COUPLINGS WITH STANDARDIZED ENCLOSED ELECTRIC MOTORS  
 ACCOUPLEMENTS AVEC MOTEURS ÉLECTRIQUES FERMÉS NORMALISÉS  
 ACCOPIAMENTI CON MOTORI ELETTRICI CHIUSI NORMALIZZATI

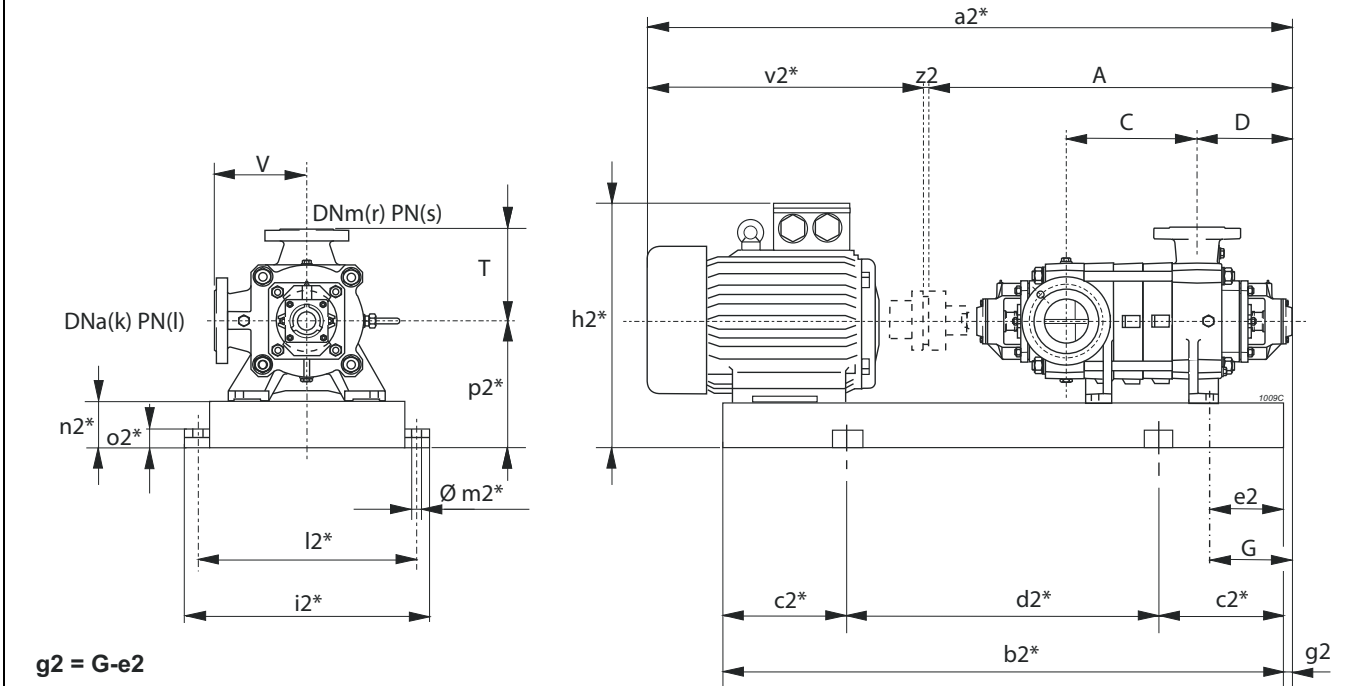

\* Valori indicativi in funzione della marca di motore utilizzato  
 Indicative values according to the type of motor installed

Pump Pompe Pompa		Motor Moteur Motore		BGAM	A	C	D	G	T	V	a2*	b2*	c2*	d2*	e2	h2*	i2*	k	l	l2*	m2*	n2*	o2*	p2*	r	s	v2*	z2	Weight Poids Peso
Serie Série Serie	Type Type Tipo	[kW]	Size Taille Grand.	Type Type Tipo	[mm]																								[kg]
PM(S)	80/2	18,5	160L	615/DN	804,5	170,5	274	245	245	245	1435,5	1151	200	751	50	551	550	100	(1)	500	20	100	42	300	80	(2)	627	4	377
PM(S)	/2	22	180M	616/EN	804,5	170,5	274	245	245	245	1473,5	1161	200	761	50	570	550	100	(1)	500	20	100	42	300	80	(2)	665	4	418
PM(S)	/2	30	200L	617/FN	804,5	170,5	274	245	245	245	1546,5	1234	200	834	50	600	550	100	(1)	500	20	100	42	300	80	(2)	738	4	472
PM(S)	/2	37	200L	617/FN	804,5	170,5	274	245	245	245	1546,5	1234	200	834	50	600	550	100	(1)	500	20	100	42	300	80	(2)	738	4	500
PM(S)	80/3	30	200L	618/FN	874,5	240,5	274	245	245	245	1616,5	1304	200	904	50	600	550	100	(1)	500	20	100	42	300	80	(2)	738	4	495
PM(S)	/3	37	200L	618/FN	874,5	240,5	274	245	245	245	1616,5	1304	200	904	50	600	550	100	(1)	500	20	100	42	300	80	(2)	738	4	523
PM(S)	/3	45	225M	619/FN	874,5	240,5	274	245	245	245	1653,5	1350	250	850	70	675	585	100	(1)	535	20	120	42	345	80	(2)	775	4	599
PM(S)	/3	55	250M	620/GN	874,5	240,5	274	245	245	245	1748,5	1412	250	912	60	745	635	100	(1)	585	20	120	42	370	80	(2)	870	4	689
PM(S)	80/4	37	200L	621/FN	944,5	310,5	274	245	245	245	1686,5	1374	250	874	50	600	550	100	(1)	500	20	100	42	300	80	(2)	738	4	545
PM(S)	/4	45	225M	622/FN	944,5	310,5	274	245	245	245	1723,5	1420	250	920	70	675	585	100	(1)	535	20	120	42	345	80	(2)	775	4	622
PM(S)	/4	55	250M	623/GN	944,5	310,5	274	245	245	245	1818,5	1482	250	982	60	745	635	100	(1)	585	20	120	42	370	80	(2)	870	4	712
PM(S)	/4	75	280S	624/HN	944,5	310,5	274	245	245	245	1948,5	1559	250	1059	90	815	695	100	(1)	645	20	140	42	420	80	(2)	1000	4	934
PM(S)	/4	90	280M	625/HN	944,5	310,5	274	245	245	245	1999,5	1610	250	1110	90	815	695	100	(1)	645	20	140	42	420	80	(2)	1051	4	1063
PM(S/H)	80/5	45	225M	625/FN	1014,5	380,5	274	245	245	245	1739,5	1490	250	990	70	675	585	100	(1)	535	20	120	42	345	80	(2)	775	4	645
PM(S/H)	/5	55	250M	626/GN	1014,5	380,5	274	245	245	245	1888,5	1552	250	1052	60	745	635	100	(1)	585	20	120	42	370	80	(2)	870	4	735
PM(S/H)	/5	75	280S	627/HN	1014,5	380,5	274	245	245	245	2018,5	1629	250	1129	90	815	695	100	(1)	645	20	140	42	420	80	(2)	1000	4	957
PM(S/H)	/5	90	280M	628/HN	1014,5	380,5	274	245	245	245	2069,5	1680	300	1080	90	815	695	100	(1)	645	20	140	42	420	80	(2)	1051	4	1086
PM(S/H)	80/6	55	250M	629/GN	1084,5	450,5	274	245	245	245	1958,5	1622	250	1122	60	745	635	100	(1)	585	20	120	42	370	80	(2)	870	4	758
PM(S/H)	/6	75	280S	630/HN	1084,5	450,5	274	245	245	245	2088,5	1699	300	1099	90	815	695	100	(1)	645	20	140	42	420	80	(2)	1000	4	980
PM(S/H)	/6	90	280M	631/HN	1084,5	450,5	274	245	245	245	2139,5	1750	300	1150	90	815	695	100	(1)	645	20	140	42	420	80	(2)	1051	4	1109
PM(S/H)	/6	110	315S	632/IIN	1084,5	450,5	274	245	245	245	2269,5	1796	300	1196	90	1030	780	100	(1)	730	22	160	50	475	80	(2)	1181	4	1402
PM(S/H)	80/7	55	250M	633/GN	1154,5	520,5	274	245	245	245	2028,5	1692	300	1092	60	745	635	100	(1)	585	20	120	42	370	80	(2)	870	4	781
PM(S/H)	/7	75	280S	634/HN	1154,5	520,5	274	245	245	245	2158,5	1769	300	1169	90	815	695	100	(1)	645	20	140	42	420	80	(2)	1000	4	1004
PM(S/H)	/7	90	280M	635/HN	1154,5	520,5	274	245	245	245	2209,5	1820	300	1220	90	815	695	100	(1)	645	20	140	42	420	80	(2)	1051	4	1132
PM(S/H)	/7	110	315S	636/IIN	1154,5	520,5	274	245	245	245	2339,5	1866	300	1266	90	1030	780	100	(1)	730	22	160	50	475	80	(2)	1181	4	1426
PM(S/H)	/7	132	315M	637/IIN	1154,5	520,5	274	245	245	245	2449,5	1925	300	1325	90	1030	780	100	(1)	730	22	160	50	475	80	(2)	1291	4	1500
PM(S/H)	80/8	75	280S	638/HN	1224,5	590,5	274	245	245	245	2228,5	1839	300	1239	90	815	695	100	(1)	645	20	140	42	420	80	(2)	1000	4	1027
PM(S/H)	/8	90	280M	639/HN	1224,5	590,5	274	245	245	245	2279,5	1890	300	1290	90	815	695	100	(1)	645	20	140	42	420	80	(2)	1051	4	1156
PM(S/H)	/8	110	315S	640/IIN	1224,5	590,5	274	245	245	245	2409,5	1936	300	1336	90	1030	780	100	(1)	730	22	160	50	475	80	(2)	1181	4	1449

BGAM = Base and coupling

\* = Indicatives values according to the type of motor installed.

○ Motor in IE4 efficiency class according to EU REGULATION 2019/1781. Available in other efficiency classes for non-EU markets.

- (1) PM=25 bar PMS=25 bar PMH=40 bar
- (2) PM=40 bar PMS=63 bar PMH=100 bar

BGAM = Socle et accouplement

\* = Valeurs indicatives en fonction de la marque du moteur utilisé.

○ Moteur en classe de rendement IE4 conformément au RÈGLEMENT UE2019/1781. Disponibilité en différentes classes de rendement pour les marchés hors UE.

- (1) PM=25 bar PMS=25 bar PMH=40 bar
- (2) PM=40 bar PMS=63 bar PMH=100 bar

BGAM = Base giunto e coprigiunto

\* = Valori indicativi in funzione della marca di motore utilizzato.

○ Motore in classe di efficienza IE4 in conformità al REGOLAMENTO UE2019/1781. Disponibili in altre classi di efficienza per mercati extra UE.

- (1) PM=25 bar PMS=25 bar PMH=40 bar
- (2) PM=40 bar PMS=63 bar PMH=100 bar

Selection - dimensions and weights for base mounted electric pumps  
 Sélection - dimensions et poids des électropompes sur socle  
 Selezione - dimensioni e pesi elettropompe su base

COUPLINGS WITH STANDARDIZED ENCLOSED ELECTRIC MOTORS  
 ACCOUPLEMENTS AVEC MOTEURS ÉLECTRIQUES FERMÉS NORMALISÉS  
 ACCOPIAMENTI CON MOTORI ELETTRICI CHIUSI NORMALIZZATI

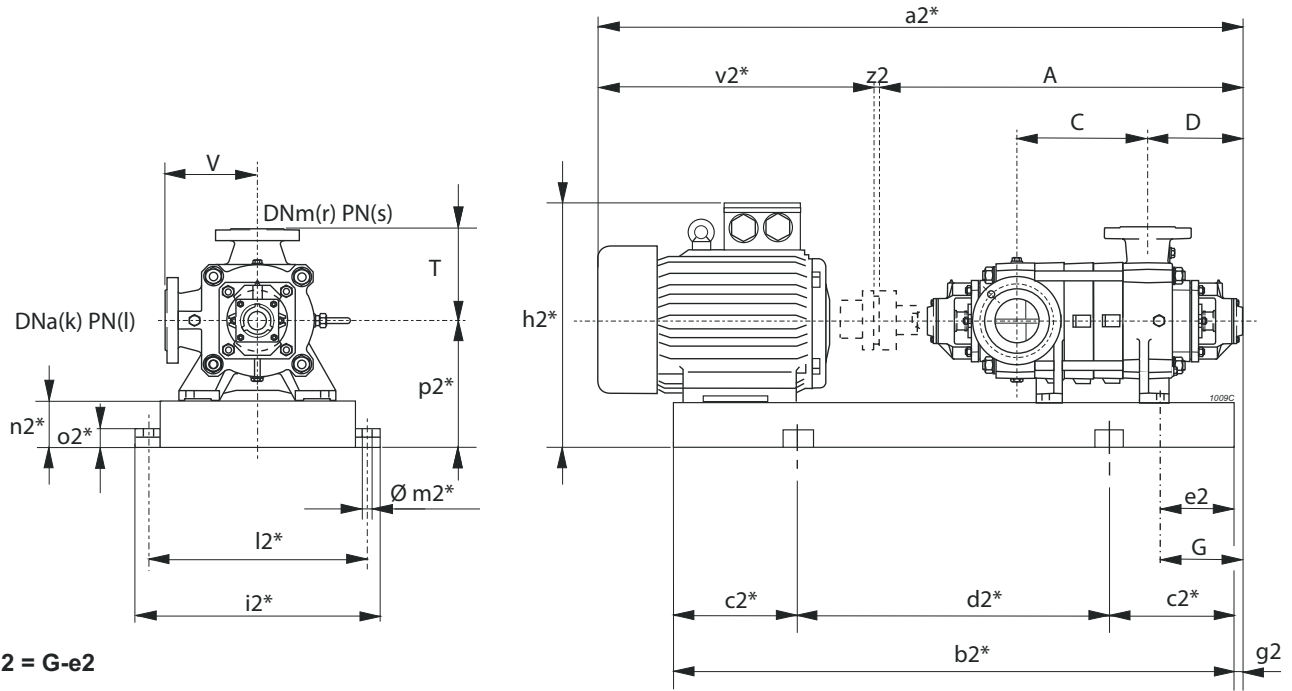

$g2 = G - e2$

\* Valori indicativi in funzione della marca di motore utilizzato  
 Indicatives values according to the type of motor installed

Pump Pompe Pompa	Motor Moteur Motore	BGAM	A	C	D	G	T	V	a2*	b2*	c2*	d2*	e2	h2*	i2*	k	l	l2*	m2*	n2*	o2*	p2*	r	s	v2*	z2	Weight Poids Peso	
Series Série Serie	Type Type Tipo	Size Taille Grand.	Type Type Tipo	[mm]																						[kg]		
PM(S/H)	/8	132	315M	641/IN	1224,5	590,5	274	245	245	2519,5	2046	350	1346	90	1030	780	100	(1)	730	22	160	50	475	80	(2)	1291	4	1525
PM(S/H)	/8	160	315L	641/IN	1224,5	590,5	274	245	245	2519,5	2046	350	1346	90	1030	780	100	(1)	730	22	160	50	475	80	(2)	1291	4	1603
PM(S/H)	/8	200	315L	642/IE4/LQ	1224,5	590,5	274	245	245	2609,5	2136	350	1436	198	1030	780	100	(1)	730	22	160	50	475	80	(2)	1381	4	1719
PM(S/H)	80/9	75	280S	643/HN	1294,5	660,5	274	245	245	2298,5	1909	300	1309	90	815	695	100	(1)	645	20	140	42	420	80	(2)	1000	4	1050
PM(S/H)	/9	90	280M	644/HN	1294,5	660,5	274	245	245	2349,5	1960	350	1260	90	815	695	100	(1)	645	20	140	42	420	80	(2)	1051	4	1179
PM(S/H)	/9	110	315S	645/IN	1294,5	660,5	274	245	245	2479,5	2006	350	1306	90	1030	780	100	(1)	730	22	160	50	475	80	(2)	1181	4	1473
PM(S/H)	/9	132	315M	646/IN	1294,5	660,5	274	245	245	2589,5	2065	350	1365	90	1030	780	100	(1)	730	22	160	50	475	80	(2)	1291	4	1547
PM(S/H)	/9	160	315L	647/LQ	1294,5	660,5	274	245	245	2589,5	2116	350	1416	90	1030	780	100	(1)	730	22	160	50	475	80	(2)	1291	4	1632
PM(S/H)	/9	200	315L	647/IE4/LQ	1294,5	660,5	274	245	245	2679,5	2206	350	1506	198	1030	780	100	(1)	730	22	160	50	475	80	(2)	1381	4	1742
PM(S/H)	80/10	90	280M	648/HN	1364,5	730,5	274	245	245	2419,5	2030	350	1330	90	815	695	100	(1)	645	20	140	42	420	80	(2)	1051	4	1202
PM(S/H)	/10	110	315S	649/IN	1364,5	730,5	274	245	245	2549,5	2076	350	1376	90	1030	780	100	(1)	730	22	160	50	475	80	(2)	1181	4	1497
PM(S/H)	/10	132	315M	650/IN	1364,5	730,5	274	245	245	2659,5	2186	350	1486	90	1030	780	100	(1)	730	22	160	50	475	80	(2)	1291	4	1573
PM(S/H)	/10	160	315L	650/IN	1364,5	730,5	274	245	245	2659,5	2186	350	1486	90	1030	780	100	(1)	730	22	160	50	475	80	(2)	1291	4	1651
PM(S/H)	/10	200	315L	651/IE4/LQ	1364,5	730,5	274	245	245	2749,5	2276	400	1476	198	1030	780	100	(1)	730	22	160	50	475	80	(2)	1381	4	1765
PM(S/H)	80/11	90	280M	6648/HN	1434,5	800,5	274	245	245	2489,5	2100	350	1400	90	815	695	100	(1)	645	20	140	42	420	80	(2)	1051	4	1225
PM(S/H)	/11	110	315S	1200/IS	1434,5	800,5	274	245	245	2619,5	2146	350	1446	90	1030	780	100	(1)	730	22	160	50	475	80	(2)	1181	4	1520
PM(S/H)	/11	132	315M	1201/IN	1434,5	800,5	274	245	245	2729,5	2256	400	1456	90	1030	780	100	(1)	730	22	160	50	475	80	(2)	1291	4	1596
PM(S/H)	/11	160	315L	1201/IN	1434,5	800,5	274	245	245	2729,5	2256	400	1456	90	1030	780	100	(1)	730	22	160	50	475	80	(2)	1291	4	1674
PM(S/H)	/11	200	315L	1202/IE4/LQ	1434,5	800,5	274	245	245	2819,5	2346	400	1546	198	1030	780	100	(1)	730	22	160	50	475	80	(2)	1381	4	1789
PM(S/H)	80/12	110	315S	1203/IN	1504,5	870,5	274	245	245	2689,5	2216	350	1516	90	1030	780	100	(1)	730	22	160	50	475	80	(2)	1181	4	1544
PM(S/H)	/12	132	315M	1204/IN	1504,5	870,5	274	245	245	2799,5	2326	400	1526	90	1030	780	100	(1)	730	22	160	50	475	80	(2)	1291	4	1620
PM(S/H)	/12	160	315L	1204/IN	1504,5	870,5	274	245	245	2799,5	2326	400	1526	90	1030	780	100	(1)	730	22	160	50	475	80	(2)	1291	4	1698
PM(S/H)	/12	200	315L	1205/IE4/LQ	1504,5	870,5	274	245	245	2889,5	2416	400	1616	198	1030	780	100	(1)	730	22	160	50	475	80	(2)	1381	4	1812
PM(S/H)	/12	250	355M	1206/LQ	1504,5	870,5	274	245	245	3034,5	2400	400	1600	110	1136	880	100	(1)	830	22	180	50	535	80	(2)	1526	4	2256
PM(H)	80/13	110	315S	12203/IN	1574,5	940,5	274	245	245	2759,5	2286	400	1486	90	1030	780	100	(1)	730	22	160	50	475	80	(2)	1181	4	1567
PM(H)	/13	132	315M	1207/IN	1574,5	940,5	274	245	245	2869,5	2396	400	1596	90	1030	780	100	(1)	730	22	160	50	475	80	(2)	1291	4	1644
PM(H)	/13	160	315L	1207/IN	1574,5	940,5	274	245	245	2869,5	2396	400	1596	90	1030	780	100	(1)	730	22	160	50	475	80	(2)	1291	4	1722
PM(H)	/13	200	315L	1208/IE4/LQ	1574,5	940,5	274	245	245	2959,5	2486	400	1686	198	1030	780	100	(1)	730	22	160	50	475	80	(2)	1381	4	1835
PM(H)	/13	250	355M	1209/LQ	1574,5	940,5	274	245	245	3104,5	2470	400	1670	110	1136	880	100	(1)	830	22	180	50	535	80	(2)	1526	4	2280

BGAM = Base and coupling

\* = Indicatives values according to the type of motor installed.

○ Motor in IE4 efficiency class according to EU REGULATION 2019/1781. Available in other efficiency classes for non-EU markets.

(1) PM=25 bar PMS=25 bar PMH=40 bar

(2) PM=40 bar PMS=63 bar PMH=100 bar

BGAM = Socle et accouplement

\* = Valeurs indicatives en fonction de la marque du moteur utilisé.

○ Moteur en classe de rendement IE4 conformément au RÈGLEMENT UE2019/1781. Disponibilité en différentes classes de rendement pour les marchés hors UE.

(1) PM=25 bar PMS=25 bar PMH=40 bar

(2) PM=40 bar PMS=63 bar PMH=100 bar

BGAM = Base giunto e coprigiunto

\* = Valori indicativi in funzione della marca di motore utilizzato.

○ Motore in classe di efficienza IE4 in conformità al REGOLAMENTO UE2019/1781. Disponibili in altre classi di efficienza per mercati extra UE.

(1) PM=25 bar PMS=25 bar PMH=40 bar

(2) PM=40 bar PMS=63 bar PMH=100 bar

Selection - dimensions and weights for base mounted electric pumps  
*Sélection - dimensions et poids des électropompes sur socle*  
 Selezione - dimensioni e pesi elettropompe su base

COUPLINGS WITH STANDARDIZED ENCLOSED ELECTRIC MOTORS  
 ACCOUPLEMENTS AVEC MOTEURS ÉLECTRIQUES FERMÉS NORMALISÉS  
 ACCOPIAMENTI CON MOTORI ELETTRICI CHIUSI NORMALIZZATI

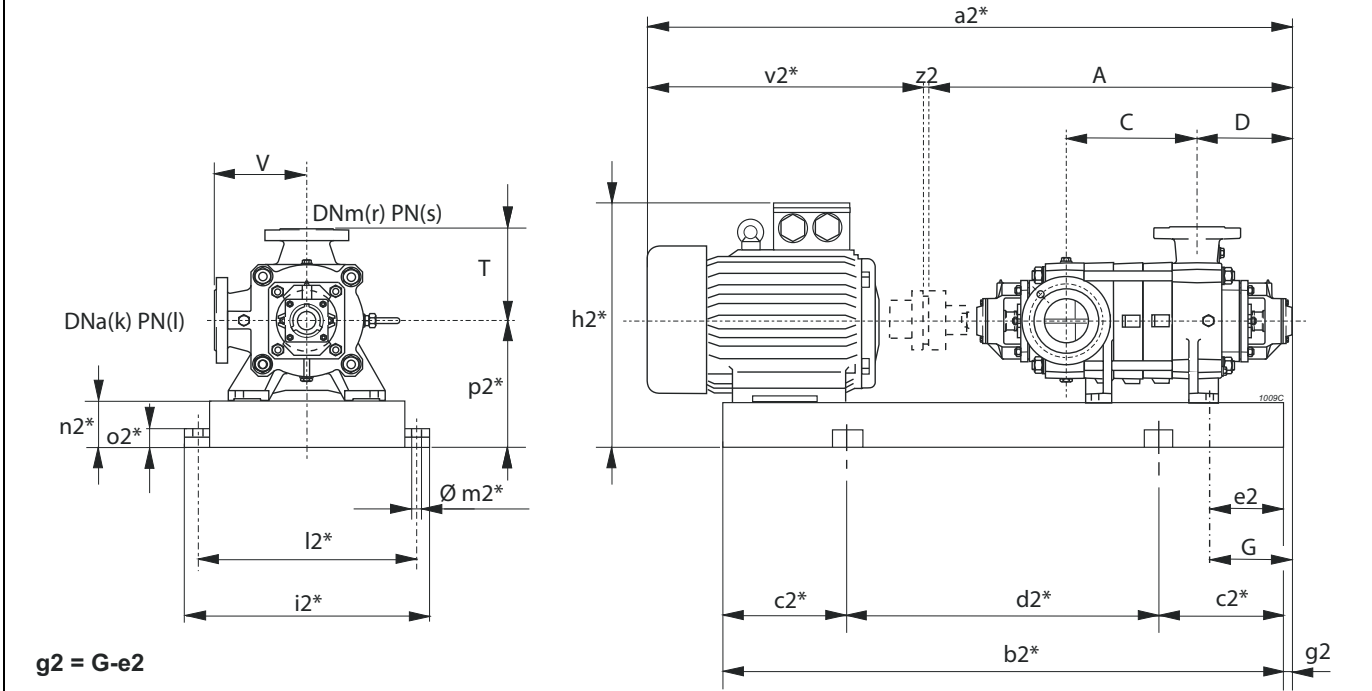

\* Valori indicativi in funzione della marca di motore utilizzato  
*Indicatives values according to the type of motor installed*

Pump Pompe Pompa		Motor Moteur Motore		BGAM	A	C	D	G	T	V	a2*	b2*	c2*	d2*	e2	h2*	i2*	k	l	l2*	m2*	n2*	o2*	p2*	r	s	v2*	z2	Weight Poids Peso
Series Série Serie	Type Type Tipo	[kW]	Size Taille Grand.	Type Type Tipo	[mm]																								[kg]
PM(H)	80/14	132	315M	1210/IN	1644,5	1010,5	274	245	245	245	2939,5	2466	400	1666	90	1030	780	100	(1)	730	22	160	50	475	80	(2)	1291	4	1667
PM(H)	/14	160	315L	1210/IN	1644,5	1010,5	274	245	245	245	2939,5	2466	400	1666	90	1030	780	100	(1)	730	22	160	50	475	80	(2)	1291	4	1745
PM(H)	/14	200	315L	1211/IE4/LQ	1644,5	1010,5	274	245	245	245	3029,5	2556	450	1656	198	1030	780	100	(1)	730	22	160	50	475	80	(2)	1381	4	1858
PM(H)	/14	250	355M	1212/LQ	1644,5	1010,5	274	245	245	245	3174,5	2540	400	1740	110	1136	880	100	(1)	830	22	180	50	535	80	(2)	1526	4	2304
PM(H)	80/15	132	315M	1213/IN	1714,5	1080,5	274	245	245	245	3009,5	2536	400	1736	90	1030	780	100	(1)	730	22	160	50	475	80	(2)	1291	4	1691
PM(H)	/15	160	315L	1213/IN	1714,5	1080,5	274	245	245	245	3009,5	2536	400	1736	90	1030	780	100	(1)	730	22	160	50	475	80	(2)	1291	4	1769
PM(H)	/15	200	315L	1214/IE4/LQ	1714,5	1080,5	274	245	245	245	3099,5	2626	450	2726	198	1030	780	100	(1)	730	22	160	50	475	80	(2)	1381	4	1881
PM(H)	/15	250	355M	1215/LQ	1714,5	1080,5	274	245	245	245	3244,5	2680	450	1780	110	1136	880	100	(1)	830	22	180	50	535	80	(2)	1526	4	2331
PM(H)	/15	280	355L	1215/LQ	1714,5	1080,5	274	245	245	245	3244,5	2680	450	1780	110	1136	880	100	(1)	830	22	180	50	535	80	(2)	1526	4	2456
PM(H)	80/16	132	315M	1216/IN	1784,5	1150,5	274	245	245	245	3079,5	2606	450	1706	90	1030	780	100	(1)	730	22	160	50	475	80	(2)	1291	4	1714
PM(H)	/16	160	315L	1216/IN	1784,5	1150,5	274	245	245	245	3079,5	2606	450	1706	90	1030	780	100	(1)	730	22	160	50	475	80	(2)	1291	4	1792
PM(H)	/16	200	315L	1217/IE4/LQ	1784,5	1150,5	274	245	245	245	3169,5	2696	450	2796	198	1030	780	100	(1)	730	22	160	50	475	80	(2)	1381	4	1904
PM(H)	/16	250	355M	1218/LQ	1784,5	1150,5	274	245	245	245	3314,5	2750	450	1850	110	1136	880	100	(1)	830	22	180	50	535	80	(2)	1526	4	2357
PM(H)	/16	315	355L	1218/MQ	1784,5	1150,5	274	245	245	245	3314,5	2750	450	1850	110	1136	880	100	(1)	830	22	180	50	535	80	(2)	1526	4	2486

BGAM = Base and coupling

\* = Indicatives values according to the type of motor installed.

○ Motor in IE4 efficiency class according to EU REGULATION 2019/1781. Available in other efficiency classes for non-EU markets.

- (1) PM=25 bar PMS=25 bar PMH=40 bar  
 (2) PM=40 bar PMS=63 bar PMH=100 bar

BGAM = Socle et accouplement

\* = Valeurs indicatives en fonction de la marque du moteur utilisé.

○ Moteur en classe de rendement IE4 conformément au RÈGLEMENT UE2019/1781. Disponibilité en différentes classes de rendement pour les marchés hors UE.

- (1) PM=25 bar PMS=25 bar PMH=40 bar  
 (2) PM=40 bar PMS=63 bar PMH=100 bar

BGAM = Base giunto e coprigiunto

\* = Valori indicativi in funzione della marca di motore utilizzato.

○ Motore in classe di efficienza IE4 in conformità al REGOLAMENTO UE2019/1781. Disponibili in altre classi di efficienza per mercati extra UE.

- (1) PM=25 bar PMS=25 bar PMH=40 bar  
 (2) PM=40 bar PMS=63 bar PMH=100 bar

Selection - dimensions and weights for base mounted electric pumps  
 Sélection - dimensions et poids des électropompes sur socle  
 Selezione - dimensioni e pesi elettropompe su base

COUPLINGS WITH STANDARDIZED ENCLOSED ELECTRIC MOTORS  
 ACCOUPLEMENTS AVEC MOTEURS ÉLECTRIQUES FERMÉS NORMALISÉS  
 ACCOPIAMENTI CON MOTORI ELETTRICI CHIUSI NORMALIZZATI

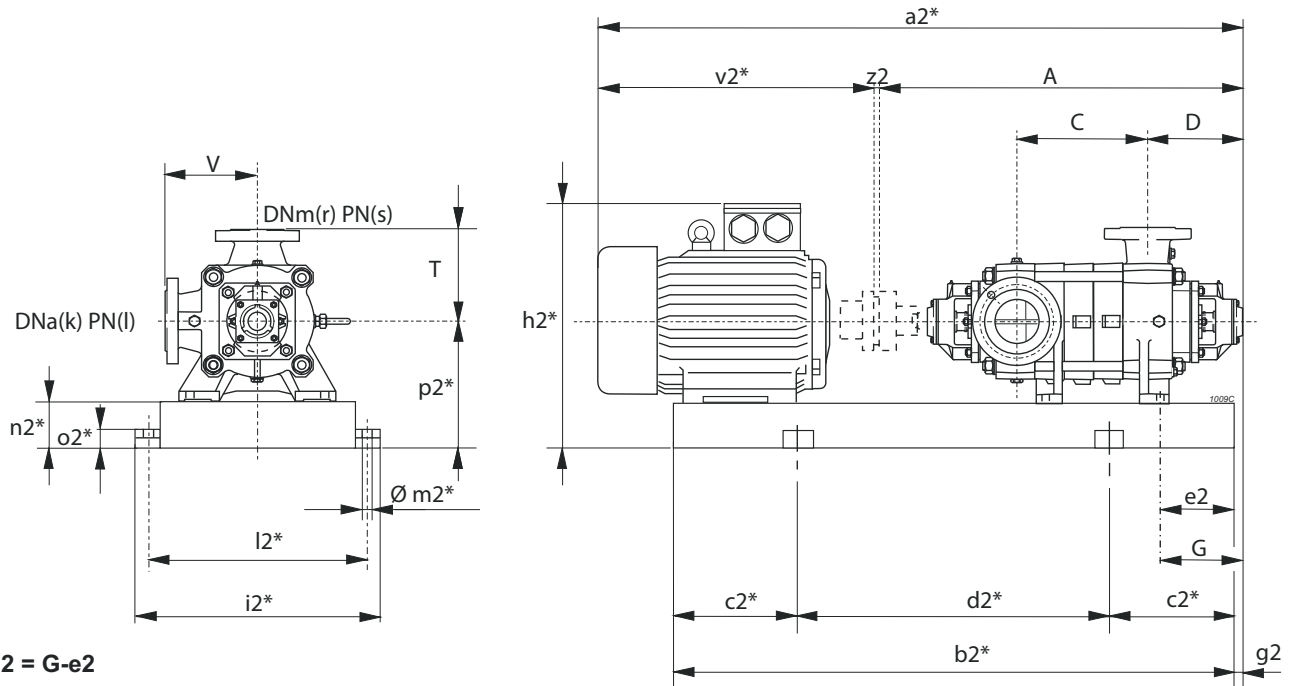

\* Valori indicativi in funzione della marca di motore utilizzato  
 Indicatives values according to the type of motor installed

Pump Pompe Pompa		Motor Moteur Motore		BGAM	A	C	D	G	T	V	a2*	b2*	c2*	d2*	e2	h2*	i2*	k	l	l2*	m2*	n2*	o2*	p2*	r	s	v2*	z2	Weight Poids Peso				
Series Série Serie	Type Type Tipo	[kW]	Size Taille Grand.	Type Type Tipo	[mm]																												[kg]
PM(S)	80/2	2,2	100L	655/CN	804,5	170,5	274	245	245	245	1213,5	915	150	615	50	450	550	100	(1)	500	20	100	42	300	80	(2)	405	4	257				
PM(S)	/2	3	100L	655/CN	804,5	170,5	274	245	245	245	1213,5	915	150	615	50	450	550	100	(1)	500	20	100	42	300	80	(2)	405	4	261				
PM(S)	/2	4	112M	656/CN	804,5	170,5	274	245	245	245	1248,5	922	150	622	50	472	550	100	(1)	500	20	100	42	300	80	(2)	440	4	262				
PM(S)	/2	5,5	132S	657/DN	804,5	170,5	274	245	245	245	1263,5	963	150	663	50	492	550	100	(1)	500	20	100	42	300	80	(2)	455	4	272				
PM(S)	80/3	3	100L	6655/CN	874,5	240,5	274	245	245	245	1283,5	985	150	685	50	450	550	100	(1)	500	20	100	42	300	80	(2)	405	4	283				
PM(S)	/3	4	112M	658/CN	874,5	240,5	274	245	245	245	1318,5	992	150	692	50	472	550	100	(1)	500	20	100	42	300	80	(2)	440	4	285				
PM(S)	/3	5,5	132S	659/DN	874,5	240,5	274	245	245	245	1333,5	1033	150	733	50	492	550	100	(1)	500	20	100	42	300	80	(2)	455	4	294				
PM(S)	/3	7,5	132M	660/DN	874,5	240,5	274	245	245	245	1368,5	1071	200	671	50	492	550	100	(1)	500	20	100	42	300	80	(2)	490	4	304				
PM(S)	80/4	4	112M	6658/CN	944,5	310,5	274	245	245	245	1388,5	1062	200	662	50	472	550	100	(1)	500	20	100	42	300	80	(2)	440	4	307				
PM(S)	/4	5,5	132S	661/DN	944,5	310,5	274	245	245	245	1403,5	1103	200	703	50	492	550	100	(1)	500	20	100	42	300	80	(2)	455	4	317				
PM(S)	/4	7,5	132M	662/DN	944,5	310,5	274	245	245	245	1438,5	1141	200	741	50	492	550	100	(1)	500	20	100	42	300	80	(2)	490	4	326				
PM(S)	/4	11	160M	663/EN	944,5	310,5	274	245	245	245	1575,5	1247	200	847	50	551	550	100	(1)	500	20	100	42	300	80	(2)	627	4	412				
PM(S/H)	80/5	5,5	132S	664/DN	1014,5	380,5	274	245	245	245	1473,5	1173	200	773	50	492	550	100	(1)	500	20	100	42	300	80	(2)	455	4	339				
PM(S/H)	/5	7,5	132M	665/DN	1014,5	380,5	274	245	245	245	1508,5	1211	200	811	50	492	550	100	(1)	500	20	100	42	300	80	(2)	490	4	349				
PM(S/H)	/5	11	160M	666/EN	1014,5	380,5	274	245	245	245	1645,5	1317	200	917	50	551	550	100	(1)	500	20	100	42	300	80	(2)	627	4	435				
PM(S/H)	/5	15	160L	667/EN	1014,5	380,5	274	245	245	245	1645,5	1361	250	861	50	551	550	100	(1)	500	20	100	42	300	80	(2)	627	4	448				
PM(S/H)	80/6	7,5	132M	668/DN	1084,5	450,5	274	245	245	245	1578,5	1281	200	881	50	492	550	100	(1)	500	20	100	42	300	80	(2)	490	4	371				
PM(S/H)	/6	11	160M	669/EN	1084,5	450,5	274	245	245	245	1715,5	1387	250	887	50	551	550	100	(1)	500	20	100	42	300	80	(2)	627	4	457				
PM(S/H)	/6	15	160L	670/EN	1084,5	450,5	274	245	245	245	1715,5	1431	250	931	50	551	550	100	(1)	500	20	100	42	300	80	(2)	627	4	470				
PM(S/H)	80/7	7,5	132M	671/DN	1154,5	520,5	274	245	245	245	1648,5	1351	250	851	50	492	550	100	(1)	500	20	100	42	300	80	(2)	490	4	394				
PM(S/H)	/7	11	160M	672/EN	1154,5	520,5	274	245	245	245	1785,5	1457	250	957	50	551	550	100	(1)	500	20	100	42	300	80	(2)	627	4	480				
PM(S/H)	/7	15	160L	673/EN	1154,5	520,5	274	245	245	245	1785,5	1501	250	1001	50	551	550	100	(1)	500	20	100	42	300	80	(2)	627	4	493				
PM(S/H)	/7	18,5	180M	674/FN	1154,5	520,5	274	245	245	245	1823,5	1511	250	1011	50	570	550	100	(1)	500	20	100	42	300	80	(2)	665	4	530				
PM(S/H)	80/8	11	160M	676/EN	1224,5	590,5	274	245	245	245	1855,5	1527	250	1027	50	551	550	100	(1)	500	20	100	42	300	80	(2)	627	4	502				
PM(S/H)	/8	15	160L	677/EN	1224,5	590,5	274	245	245	245	1855,5	1571	250	1071	50	551	550	100	(1)	500	20	100	42	300	80	(2)	627	4	515				
PM(S/H)	/8	18,5	180M	678/FN	1224,5	590,5	274	245	245	245	1893,5	1581	250	1081	50	570	550	100	(1)	500	20	100	42	300	80	(2)	665	4	552				
PM(S/H)	80/9	11	160M	679/EN	1294,5	660,5	274	245	245	245	1925,5	1597	250	1097	50	551	550	100	(1)	500	20	100	42	300	80	(2)	627	4	525				
PM(S/H)	/9	15	160L	680/EN	1294,5	660,5	274	245	245	245	1925,5	1641	250	1141	50	551	550	100	(1)	500	20	100	42	300	80	(2)	627	4	537				
PM(S/H)	/9	18,5	180M	681/FN	1294,5	660,5	274	245	245	245	1963,5	1651	300	1051	50	570	550	100	(1)	500	20	100	42	300	80	(2)	665	4	575				
PM(S/H)	/9	22	180L	682/FN	1294,5	660,5	274	245	245	245	2003,5	1689	300	1089	50	570	550	100	(1)	500	20	100	42	300	80	(2)	705	4	596				
PM(S/H)	80/10	11	160M	683/EN	1364,5	730,5	274	245	245	245	1995,5	1667	300	1067	50	551	550	100	(1)	500	20	100	42	300	80	(2)	627	4	547				
PM(S/H)	/10	15	160L	684/EN	1364,5	730,5	274	245	245	245	1995,5	1711	300	1111	50	551	550	100	(1)	500	20	100	42	300	80	(2)	627	4	560				

BGAM = Base and coupling

\* = Indicatives values according to the type of motor installed.

(1) PM=25 bar PMS=25 bar PMH=40 bar

(2) PM=40 bar PMS=63 bar PMH=100 bar

BGAM = Socle et accouplement

\* = Valeurs indicatives en fonction de la marque du moteur utilisé.

(1) PM=25 bar PMS=25 bar PMH=40 bar

(2) PM=40 bar PMS=63 bar PMH=100 bar

BGAM = Base giunto e coprigiunto

\* = Valori indicativi in funzione della marca di motore utilizzato.

(1) PM=25 bar PMS=25 bar PMH=40 bar

(2) PM=40 bar PMS=63 bar PMH=100 bar

Selection - dimensions and weights for base mounted electric pumps  
 Sélection - dimensions et poids des électropompes sur socle  
 Selezione - dimensioni e pesi elettropompe su base

COUPLINGS WITH STANDARDIZED ENCLOSED ELECTRIC MOTORS  
 ACCOUPLEMENTS AVEC MOTEURS ÉLECTRIQUES FERMÉS NORMALISÉS  
 ACCOPPIAMENTI CON MOTORI ELETTRICI CHIUSI NORMALIZZATI

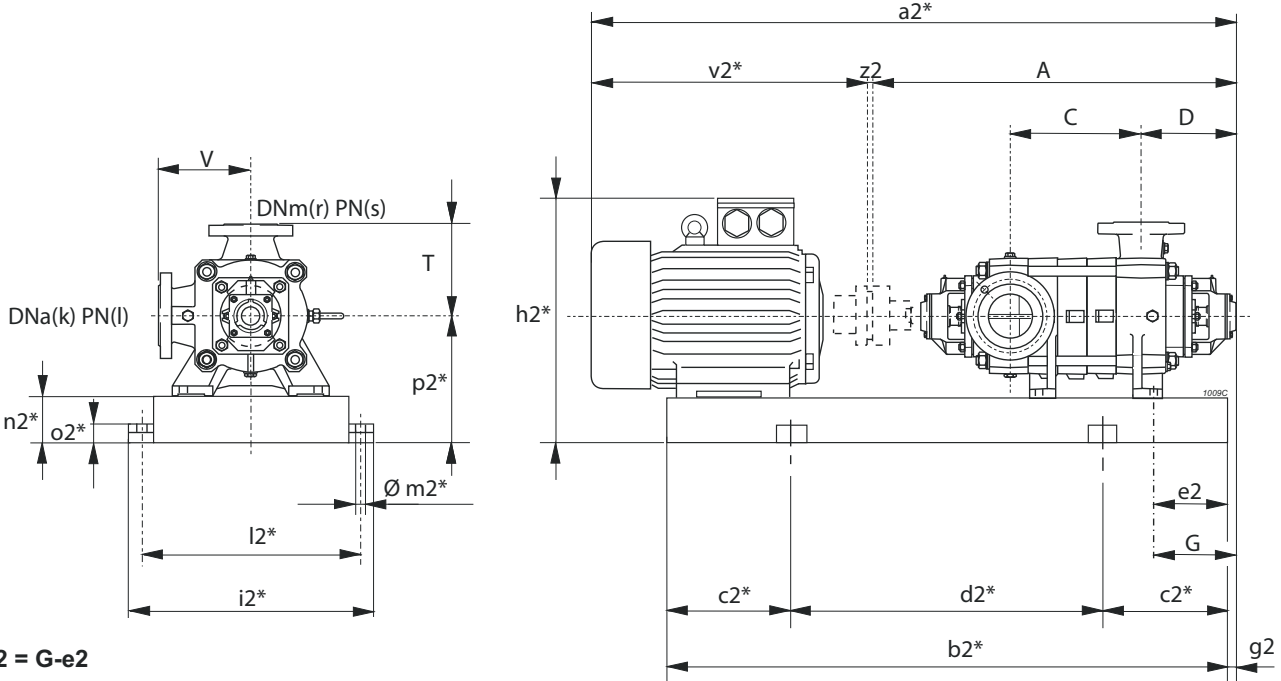

\* Valori indicativi in funzione della marca di motore utilizzato  
 Indicatives values according to the type of motor installed

Pump Pompe Pompa	Motor Moteur Motore	BGAM	A	C	D	G	T	V	a2*	b2*	c2*	d2*	e2	h2*	i2*	k	l	l2*	m2*	n2*	o2*	p2*	r	s	v2*	z2	Weight Poids Peso	
Series Série Serie	Type Type Tipo	[kW]	Size Taille Grand.	Type Type Tipo	[mm]																				[kg]			
PM(S/H)	/10	18,5	180M	685/FN	1364,5	730,5	274	245	245	2033,5	1721	300	1121	50	570	550	100	(1)	500	20	100	42	300	80	(2)	665	4	597
PM(S/H)	/10	22	180L	686/FN	1364,5	730,5	274	245	245	2073,5	1759	300	1159	50	570	550	100	(1)	500	20	100	42	300	80	(2)	705	4	618
PM(S/H)	/10	30	200L	687/GN	1364,5	730,5	274	245	245	2126,5	1794	300	1194	50	600	550	100	(1)	500	20	100	42	300	80	(2)	758	4	680
PM(S/H)	80/11	15	160L	688/EN	1434,5	800,5	274	245	245	2065,5	1781	300	1181	50	551	550	100	(1)	500	20	100	42	300	80	(2)	627	4	582
PM(S/H)	/11	18,5	180M	689/FN	1434,5	800,5	274	245	245	2103,5	1791	300	1191	50	570	550	100	(1)	500	20	100	42	300	80	(2)	665	4	620
PM(S/H)	/11	22	180L	690/FN	1434,5	800,5	274	245	245	2143,5	1829	300	1229	50	570	550	100	(1)	500	20	100	42	300	80	(2)	705	4	640
PM(S/H)	/11	30	200L	691/GN	1434,5	800,5	274	245	245	2196,5	1864	300	1264	50	600	550	100	(1)	500	20	100	42	300	80	(2)	758	4	702
PM(S/H)	80/12	15	160L	692/EN	1504,5	870,5	274	245	245	2135,5	1851	300	1251	50	551	550	100	(1)	500	20	100	42	300	80	(2)	627	4	605
PM(S/H)	/12	18,5	180M	693/FN	1504,5	870,5	274	245	245	2173,5	1861	300	1261	50	570	550	100	(1)	500	20	100	42	300	80	(2)	665	4	656
PM(S/H)	/12	22	180L	694/FN	1504,5	870,5	274	245	245	2213,5	1899	300	1299	50	570	550	100	(1)	500	20	100	42	300	80	(2)	705	4	663
PM(S/H)	/12	30	200L	695/GN	1504,5	870,5	274	245	245	2266,5	1934	300	1334	50	600	550	100	(1)	500	20	100	42	300	80	(2)	758	4	725
PM(S/H)	80/13	15	160L	1230/GN	1574,5	940,5	274	245	245	2205,5	1921	300	1321	50	551	550	100	(1)	500	20	100	42	300	80	(2)	627	4	630
PM(S/H)	/13	18,5	180M	1231/FN	1574,5	940,5	274	245	245	2243,5	1931	300	1331	50	570	550	100	(1)	500	20	100	42	300	80	(2)	665	4	665
PM(S/H)	/13	22	180L	1232/FN	1574,5	940,5	274	245	245	2283,5	1969	350	1269	50	570	550	100	(1)	500	20	100	42	300	80	(2)	705	4	685
PM(S/H)	/13	30	200L	1233/FN	1574,5	940,5	274	245	245	2336,5	2004	350	1304	50	600	550	100	(1)	500	20	100	42	300	80	(2)	758	4	747
PM(S/H)	80/14	15	160L	1234/EN	1644,5	1010,5	274	245	245	2275,5	1991	350	1291	50	551	550	100	(1)	500	20	100	42	300	80	(2)	627	4	650
PM(S/H)	/14	18,5	180M	1235/FN	1644,5	1010,5	274	245	245	2313,5	2001	350	1301	50	570	550	100	(1)	500	20	100	42	300	80	(2)	665	4	687
PM(S/H)	/14	22	180L	1236/FN	1644,5	1010,5	274	245	245	2353,5	2039	350	1339	50	570	550	100	(1)	500	20	100	42	300	80	(2)	705	4	708
PM(S/H)	/14	30	200L	1237/GN	1644,5	1010,5	274	245	245	2406,5	2074	350	1374	50	600	550	100	(1)	500	20	100	42	300	80	(2)	758	4	770
PM(S/H)	/14	37	225S	1238/HQ	1644,5	1010,5	274	245	245	2441,5	2125	350	1425	70	675	585	100	(1)	535	20	120	42	345	80	(2)	793	4	840
PM(S/H)	80/15	15	160L	1234/EN	1714,5	1080,5	274	245	245	2345,5	2061	350	1361	50	551	550	100	(1)	500	20	100	42	300	80	(2)	627	4	672
PM(S/H)	/15	18,5	180M	1239/FN	1714,5	1080,5	274	245	245	2383,5	2071	350	1371	50	570	550	100	(1)	500	20	100	42	300	80	(2)	665	4	710
PM(S/H)	/15	22	180L	1240/FN	1714,5	1080,5	274	245	245	2423,5	2109	350	1409	50	570	550	100	(1)	500	20	100	42	300	80	(2)	705	4	730
PM(S/H)	/15	30	200L	1241/GN	1714,5	1080,5	274	245	245	2476,5	2144	350	1444	50	600	550	100	(1)	500	20	100	42	300	80	(2)	758	4	792
PM(S/H)	/15	37	225S	1242/HQ	1714,5	1080,5	274	245	245	2511,5	2195	350	1495	70	675	585	100	(1)	535	20	120	42	345	80	(2)	793	4	863
PM(S/H)	80/16	18,5	180M	1243/FN	1784,5	1150,5	274	245	245	2453,5	2141	350	1441	50	570	550	100	(1)	500	20	100	42	300	80	(2)	665	4	732
PM(S/H)	/16	22	180L	1244/FN	1784,5	1150,5	274	245	245	2493,5	2179	350	1479	50	570	550	100	(1)	500	20	100	42	300	80	(2)	705	4	753
PM(S/H)	/16	30	200L	1245/GN	1784,5	1150,5	274	245	245	2546,5	2214	350	1514	50	600	550	100	(1)	500	20	100	42	300	80	(2)	758	4	815
PM(S/H)	/16	37	225S	1246/HQ	1784,5	1150,5	274	245	245	2581,5	2265	400	1465	70	675	585	100	(1)	535	20	120	42	345	80	(2)	793	4	885

BGAM = Base and coupling  
 \* = Indicatives values according to the type of motor installed.

- (1) PM=25 bar PMS=25 bar PMH=40 bar
- (2) PM=40 bar PMS=63 bar PMH=100 bar

BGAM = Socle et accouplement  
 \* = Valeurs indicatives en fonction de la marque du moteur utilisé.

- (1) PM=25 bar PMS=25 bar PMH=40 bar
- (2) PM=40 bar PMS=63 bar PMH=100 bar

BGAM = Base giunto e coprigiunto  
 \* = Valori indicativi in funzione della marca di motore utilizzato.

- (1) PM=25 bar PMS=25 bar PMH=40 bar
- (2) PM=40 bar PMS=63 bar PMH=100 bar