

Overall dimensions and weights
 Dimensions d'encombrement et poids
 Dimensioni di ingombro e pesi

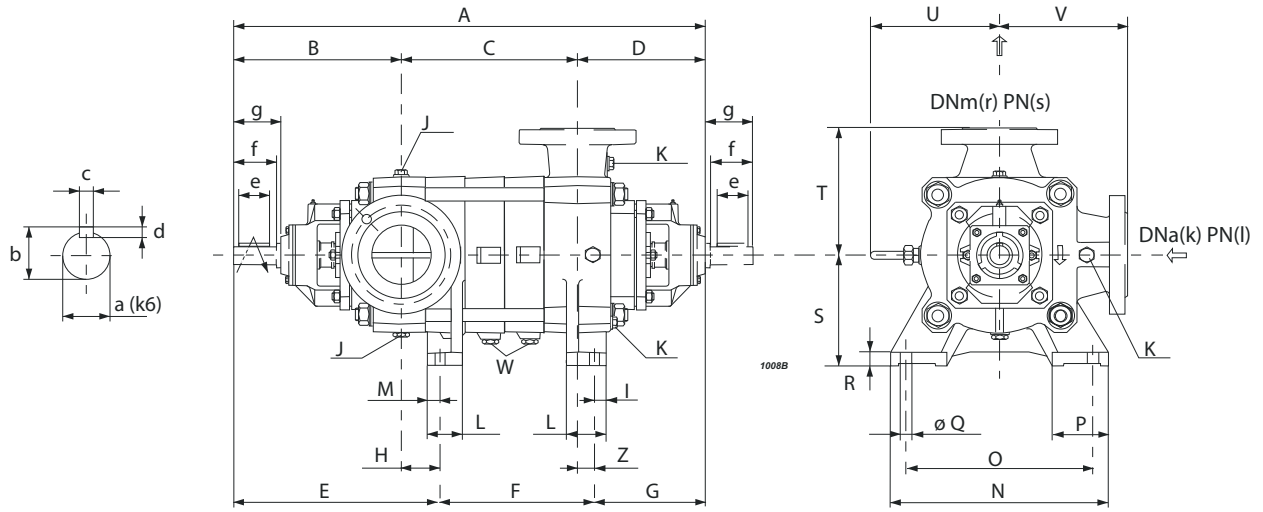

Series Série Serie	Type Type Tipo	A	B	C	D	E	F	G	H	S	T	U	V	Z	Weight Poids Peso
		[mm]													[kg]
PMX(S)T	50/2	653	289	137	227	356	100	197	67	180	195	232	195	30	108
PMX(S)T	50/3	713	289	197	227	356	160	197	67	180	195	232	195	30	121
PMX(S)T	50/4	773	289	257	227	356	220	197	67	180	195	232	195	30	134
PMX(S)T	50/5	833	289	317	227	356	280	197	67	180	195	232	195	30	148
PMX(S)T	50/6	893	289	377	227	356	340	197	67	180	195	232	195	30	161
PMX(S)T	50/7	953	289	437	227	356	400	197	67	180	195	232	195	30	174
PMX(S)T	50/8	1013	289	497	227	356	460	197	67	180	195	232	195	30	187
PMX(S)T	50/9	1073	289	557	227	356	520	197	67	180	195	232	195	30	200
PMX(S)T	50/10	1133	289	617	227	356	580	197	67	180	195	232	195	30	213
PMX(S)T	50/11	1193	289	677	227	356	640	197	67	180	195	232	195	30	226
PMX(S)T	50/12	1253	289	737	227	356	700	197	67	180	195	232	195	30	239
PMX(S)T	50/13	1313	289	797	227	356	760	197	67	180	195	232	195	30	252
PMX(S)T	50/14	1373	289	857	227	356	820	197	67	180	195	232	195	30	265
PMX(S)T	50/15	1433	289	917	227	356	880	197	67	180	195	232	195	30	278

Foot dimensions Dimensions des pieds Dimensioni dei piedi							
I	L	M	N	O	P	Q	R
[mm]							
43	60	40	370	320	90	18	23

Shaft projection Saille d'arbre Sporgenza d'albero							
a	b	c	d	e	f	g	
[mm]							
27	30	8	7	55	70	79,5	

Type Type Tipo	Flanges Brides Flange			
	(k) DNa	(l) PN	(r) DNm	(s) PN
	[mm]	[bar]	[mm]	[bar]
PMXT	65	25	50	40
PMXST	65	25	50	63

Plugs Bouchons Tappi		
J	K	W
G 1/2	G3/8	G 1/4

Selection - dimensions and weights for base mounted electric pumps
 Sélection - dimensions et poids des électropompes sur socle
 Selezione - dimensioni e pesi elettropompe su base

COUPLINGS WITH STANDARDIZED ENCLOSED ELECTRIC MOTORS
 ACCOUPLEMENTS AVEC MOTEURS ÉLECTRIQUES FERMÉS NORMALISÉS
 ACCOPIAMENTI CON MOTORI ELETTRICI CHIUSI NORMALIZZATI

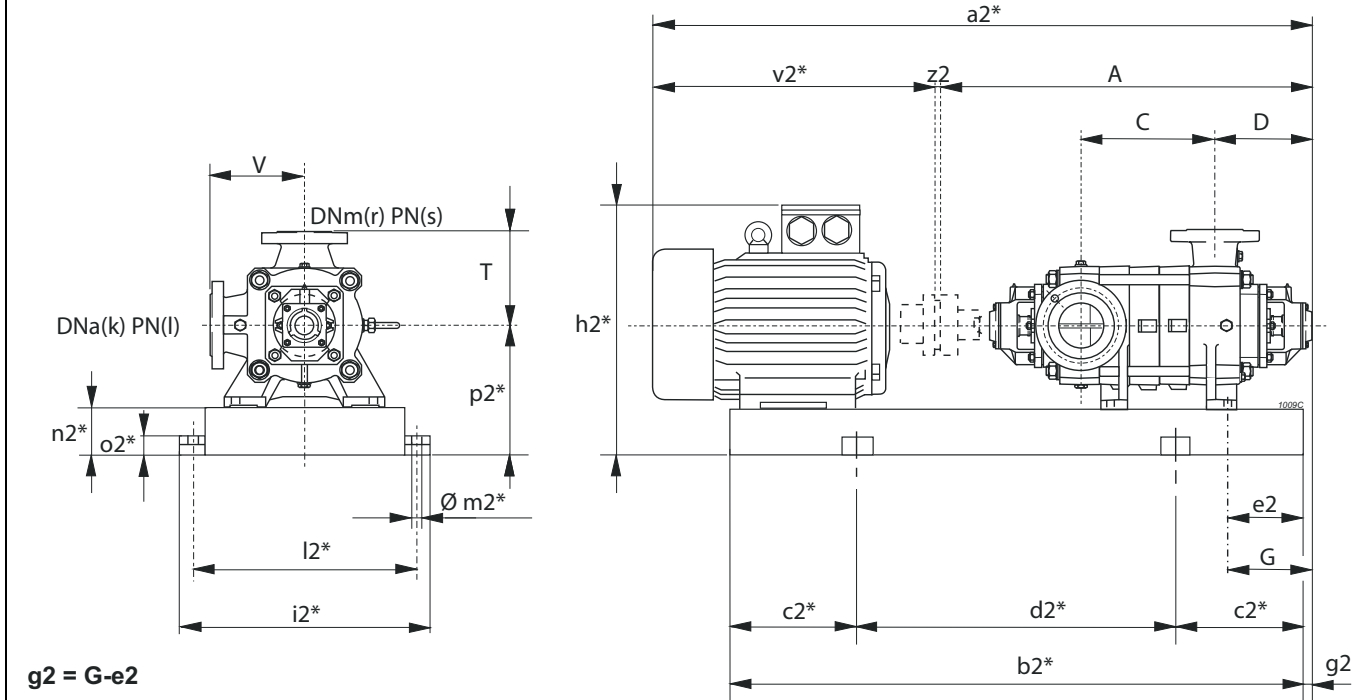

$g2 = G - e2$

* Valori indicativi in funzione della marca di motore utilizzato
 Indicatives values according to the type of motor installed

Pump Pompe Pompa	Motor Moteur Motore	BGAM	A	C	D	G	T	V	a2*	b2*	c2*	d2*	e2	h2*	i2*	k	l	l2*	m2*	n2*	o2*	p2*	r	s	v2*	z2	Weight Poids Peso		
Series Série Serie	Type Type Tipo	[kW]	Size Taille Grand.	Type Type Tipo	[mm]																							[kg]	
PMX(S)T	50/2	11	160M	876/DM	652,5	137	227	197	195	195	1283,5	993	150	693	40	531	500	65	25	450	20	100	42	280	50	(2)	627	4	267
PMX(S)T	/2	15	160M	876/DM	652,5	137	227	197	195	195	1283,5	993	150	693	40	531	500	65	25	450	20	100	42	280	50	(2)	627	4	278
PMX(S)T	50/3	15	160M	877/DM	712,5	197	227	197	195	195	1343,5	1053	200	653	40	531	500	65	25	450	20	100	42	280	50	(2)	627	4	291
PMX(S)T	/3	18,5	160L	878/DM	712,5	197	227	197	195	195	1343,5	1097	200	697	40	531	500	65	25	450	20	100	42	280	50	(2)	627	4	304
PMX(S)T	/3	22	180M	879/EM	712,5	197	227	197	195	195	1381,5	1107	200	707	40	550	500	65	25	450	20	100	42	280	50	(2)	665	4	344
PMX(S)T	50/4	18,5	160L	880/DM	772,5	257	227	197	195	195	1403,5	1157	200	757	40	531	500	65	25	450	20	100	42	280	50	(2)	627	4	317
PMX(S)T	/4	22	180M	881/EM	772,5	257	227	197	195	195	1441,5	1167	200	767	40	550	500	65	25	450	20	100	42	280	50	(2)	665	4	357
PMX(S)T	/4	30	200L	882/FM	772,5	257	227	197	195	195	1514,5	1260	200	860	60	600	540	65	25	490	20	100	42	300	50	(2)	738	4	419
PMX(S)T	50/5	22	180M	883/EM	832,5	317	227	197	195	195	1501,5	1227	200	827	40	550	500	65	25	450	20	100	42	280	50	(2)	665	4	370
PMX(S)T	/5	30	200L	884/FM	832,5	317	227	197	195	195	1574,5	1320	200	920	60	600	540	65	25	490	20	100	42	300	50	(2)	738	4	432
PMX(S)T	/5	37	200L	884/FM	832,5	317	227	197	195	195	1574,5	1320	200	920	60	600	540	65	25	490	20	100	42	300	50	(2)	738	4	460
PMX(S)T	50/6	30	200L	885/FM	892,5	377	227	197	195	195	1634,5	1380	250	880	60	600	540	65	25	490	20	100	42	300	50	(2)	738	4	445
PMX(S)T	/6	37	200L	885/FM	892,5	377	227	197	195	195	1634,5	1380	250	880	60	600	540	65	25	490	20	100	42	300	50	(2)	738	4	473
PMX(S)T	/6	45	225M	886/FM	892,5	377	227	197	195	195	1671,5	1416	250	916	70	675	585	65	25	535	20	120	42	345	50	(2)	775	4	549
PMX(S)T	50/7	30	200L	887/FM	952,5	437	227	197	195	195	1694,5	1440	250	940	60	600	540	65	25	490	20	100	42	300	50	(2)	738	4	459
PMX(S)T	/7	37	200L	887/FM	952,5	437	227	197	195	195	1694,5	1440	250	940	60	600	540	65	25	490	20	100	42	300	50	(2)	738	4	487
PMX(S)T	/7	45	225M	888/FM	952,5	437	227	197	195	195	1731,5	1476	250	976	70	675	585	65	25	535	20	120	42	345	50	(2)	775	4	563
PMX(S)T	/7	55	250M	889/GM	952,5	437	227	197	195	195	1826,5	1558	250	1058	80	745	635	65	25	585	20	120	42	370	50	(2)	870	4	673
PMX(S)T	50/8	37	200L	890/FM	1012,5	497	227	197	195	195	1754,5	1500	250	1000	60	600	540	65	25	490	20	100	42	300	50	(2)	738	4	500
PMX(S)T	/8	45	225M	891/FM	1012,5	497	227	197	195	195	1791,5	1536	250	1036	70	675	585	65	25	535	20	120	42	345	50	(2)	775	4	576
PMX(S)T	/8	55	250M	892/GM	1012,5	497	227	197	195	195	1886,5	1618	250	1118	80	745	635	65	25	585	20	120	42	370	50	(2)	870	4	686
PMX(S)T	/8	75	280S	893/HM	1012,5	497	227	197	195	195	2016,5	1675	300	1075	90	815	695	65	25	645	20	140	42	420	50	(2)	1000	4	917
PMX(S)T	50/9	45	225M	894/FM	1072,5	557	227	197	195	195	1851,5	1596	250	1096	70	675	585	65	25	535	20	120	42	345	50	(2)	775	4	590
PMX(S)T	/9	55	250M	895/GM	1072,5	557	227	197	195	195	1946,5	1678	300	1078	80	745	635	65	25	585	20	120	42	370	50	(2)	870	4	700
PMX(S)T	/9	75	280S	896/HM	1072,5	557	227	197	195	195	2076,5	1735	300	1135	90	815	695	65	25	645	20	140	42	420	50	(2)	1000	4	931
PMX(S)T	50/10	45	225M	897/FM	1132,5	617	227	197	195	195	1911,5	1656	300	1056	70	675	585	65	25	535	20	120	42	345	50	(2)	775	4	604
PMX(S)T	/10	55	250M	898/GM	1132,5	617	227	197	195	195	2006,5	1738	300	1138	80	745	635	65	25	585	20	120	42	370	50	(2)	870	4	713
PMX(S)T	/10	75	280S	899/HM	1132,5	617	227	197	195	195	2136,5	1795	300	1195	90	815	695	65	25	645	20	140	42	420	50	(2)	1000	4	945
PMX(S)T	/10	90	280M	900/HM	1132,5	617	227	197	195	195	2187,5	1846	300	1246	90	815	695	65	25	645	20	140	42	420	50	(2)	1051	4	1074

BGAM = Base and coupling
 * = Indicatives values according to the type of motor installed.

BGAM = Socle et accouplement
 * = Valeurs indicatives en fonction de la marque du moteur utilisé.

BGAM = Base giunto e coprigiunto
 * = Valori indicativi in funzione della marca di motore utilizzato.

○ Motor in IE4 efficiency class according to EU REGULATION 2019/1781. Available in other efficiency classes for non-EU markets.

○ Moteur en classe de rendement IE4 conformément au RÈGLEMENT UE2019/1781. Disponibilités en différentes classes de rendement pour les marchés hors UE.

○ Motore in classe di efficienza IE4 in conformità al REGOLAMENTO UE2019/1781. Disponibili in altre classi di efficienza per mercati extra UE.

(2) PMXT=40 bar PMXST=63 bar

(2) PMXT=40 bar PMXST=63 bar

(2) PMXT=40 bar PMXST=63 bar

Selection - dimensions and weights for base mounted electric pumps
 Sélection - dimensions et poids des électropompes sur socle
 Selezione - dimensioni e pesi elettropompe su base

COUPLINGS WITH STANDARDIZED ENCLOSED ELECTRIC MOTORS
 ACCOUPLEMENTS AVEC MOTEURS ÉLECTRIQUES FERMÉS NORMALISÉS
 ACCOPIAMENTI CON MOTORI ELETTRICI CHIUSI NORMALIZZATI

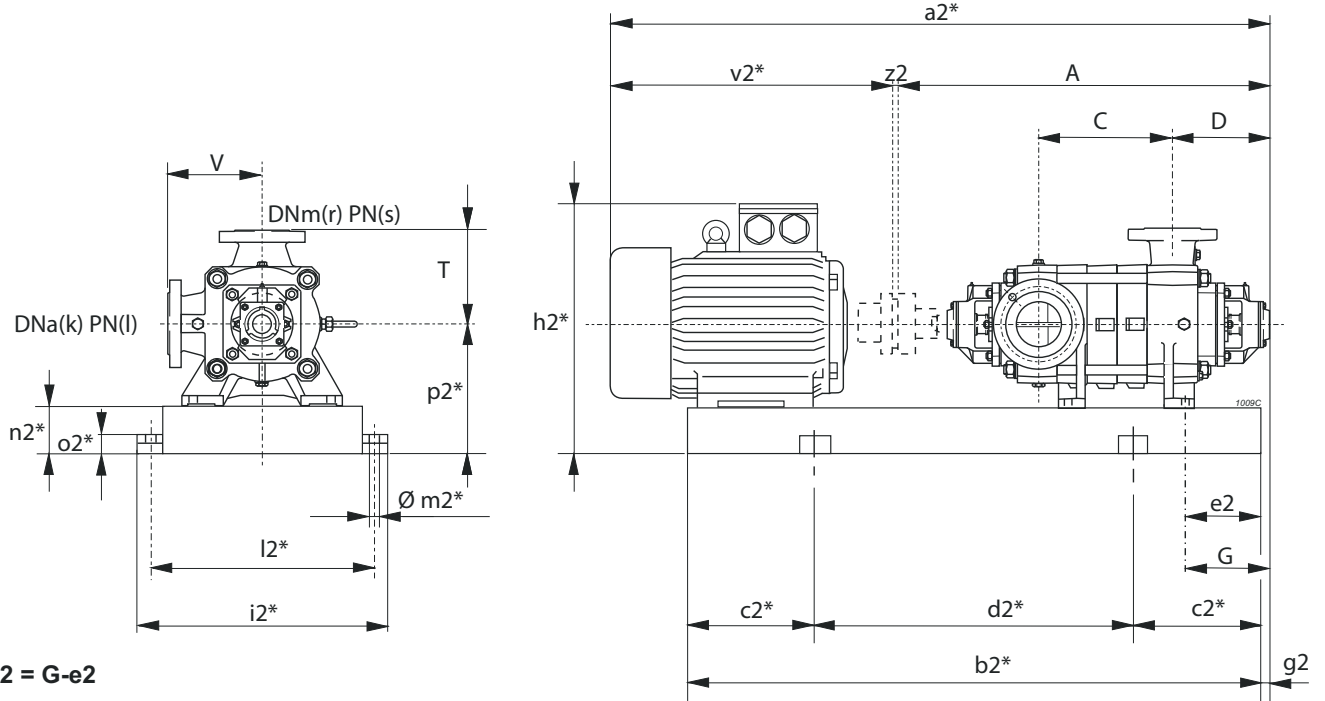

$g2 = G - e2$

* Valori indicativi in funzione della marca di motore utilizzato
 Indicatives values according to the type of motor installed

Pump Pompe Pompa		Motor Moteur Motore		BGAM	A	C	D	G	T	V	a2*	b2*	c2*	d2*	e2	h2*	i2*	k	l	l2*	m2*	n2*	o2*	p2*	r	s	v2*	z2	Weight Poids Peso
Series Série Serie	Type Type Tipo	[kW]	Size Taille Grand.	Type Type Tipo	[mm]																								[kg]
PMX(S)T	50/11	55	250M	901/GM	1192,5	677	227	197	195	195	2066,5	1798	300	1198	80	745	635	65	25	585	20	120	42	370	50	(2)	870	4	727
PMX(S)T	/11	75	280S	902/HM	1192,5	677	227	197	195	195	2196,5	1855	300	1255	90	815	695	65	25	645	20	140	42	420	50	(2)	1000	4	959
PMX(S)T	/11	90	280M	903/HM	1192,5	677	227	197	195	195	2247,5	1906	300	1306	90	815	695	65	25	645	20	140	42	420	50	(2)	1051	4	1087
PMX(S)T	50/12	55	250M	904/GM	1252,5	737	227	197	195	195	2126,5	1858	300	1258	80	745	635	65	25	585	20	120	42	370	50	(2)	870	4	741
PMX(S)T	/12	75	280S	905/HM	1252,5	737	227	197	195	195	2256,5	1915	300	1315	90	815	695	65	25	645	20	140	42	420	50	(2)	1000	4	973
PMX(S)T	/12	90	280M	906/HM	1252,5	737	227	197	195	195	2307,5	1966	350	1266	90	815	695	65	25	645	20	140	42	420	50	(2)	1051	4	1101
PMX(S)T	/12	110	315S	907/IM	1252,5	737	227	197	195	195	2437,5	2022	350	1322	100	1030	780	65	25	730	22	160	50	475	50	(2)	1181	4	1378
PMX(S)T	50/13	75	280S	908/HM	1312,5	797	227	197	195	195	2316,5	1975	350	1275	90	815	695	65	25	645	20	140	42	420	50	(2)	1000	4	987
PMX(S)T	/13	90	280M	909/HM	1312,5	797	227	197	195	195	2367,5	2026	350	1326	90	815	695	65	25	645	20	140	42	420	50	(2)	1051	4	1115
PMX(S)T	/13	110	315S	910/IM	1312,5	797	227	197	195	195	2497,5	2082	350	1382	100	1030	780	65	25	730	22	160	50	475	50	(2)	1181	4	1392
PMX(S)T	50/14	75	280S	911/HM	1372,5	857	227	197	195	195	2376,5	2035	350	1335	90	815	695	65	25	645	20	140	42	420	50	(2)	1000	4	1001
PMX(S)T	/14	90	280M	912/HM	1372,5	857	227	197	195	195	2427,5	2086	350	1386	90	815	695	65	25	645	20	140	42	420	50	(2)	1051	4	1129
PMX(S)T	/14	110	315S	913/IM	1372,5	857	227	197	195	195	2557,5	2142	350	1442	100	1030	780	65	25	730	22	160	50	475	50	(2)	1181	4	1406
PMX(S)T	50/15	75	280S	9911/HM	1432,5	917	227	197	195	195	2436,5	2095	350	1395	90	815	695	65	25	645	20	140	42	420	50	(2)	1000	4	1014
PMX(S)T	/15	90	280M	9912/HM	1432,5	917	227	197	195	195	2487,5	2146	350	1446	90	815	695	65	25	645	20	140	42	420	50	(2)	1051	4	1143
PMX(S)T	/15	110	315S	914/IM	1432,5	917	227	197	195	195	2617,5	2202	350	1502	100	1030	780	65	25	730	22	160	50	475	50	(2)	1181	4	1420
PMX(S)T	/15	132	315M	9913/IM	1432,5	917	227	197	195	195	2727,5	2261	400	1461	100	1030	780	65	25	730	22	160	50	475	50	(2)	1291	4	1494

BGAM = Base and coupling

* = Indicatives values according to the type of motor installed.

○ Motor in IE4 efficiency class according to EU REGULATION 2019/1781. Available in other efficiency classes for non-EU markets.

(2) PMXT=40 bar PMXST=63 bar

BGAM = Socle et accouplement

* = Valeurs indicatives en fonction de la marque du moteur utilisé.

○ Moteur en classe de rendement IE4 conformément au RÈGLEMENT UE2019/1781. Disponibilité en différentes classes de rendement pour les marchés hors UE.

(2) PMXT=40 bar PMXST=63 bar

BGAM = Base giunto e coprigiunto

* = Valori indicativi in funzione della marca di motore utilizzato.

○ Motore in classe di efficienza IE4 in conformità al REGOLAMENTO UE2019/1781. Disponibili in altre classi di efficienza per mercati extra UE.

(2) PMXT=40 bar PMXST=63 bar

Selection - dimensions and weights for base mounted electric pumps
 Sélection - dimensions et poids des électropompes sur socle
 Selezione - dimensioni e pesi elettropompe su base

COUPLINGS WITH STANDARDIZED ENCLOSED ELECTRIC MOTORS
 ACCOUPLEMENTS AVEC MOTEURS ÉLECTRIQUES FERMÉS NORMALISÉS
 ACCOPIAMENTI CON MOTORI ELETTRICI CHIUSI NORMALIZZATI

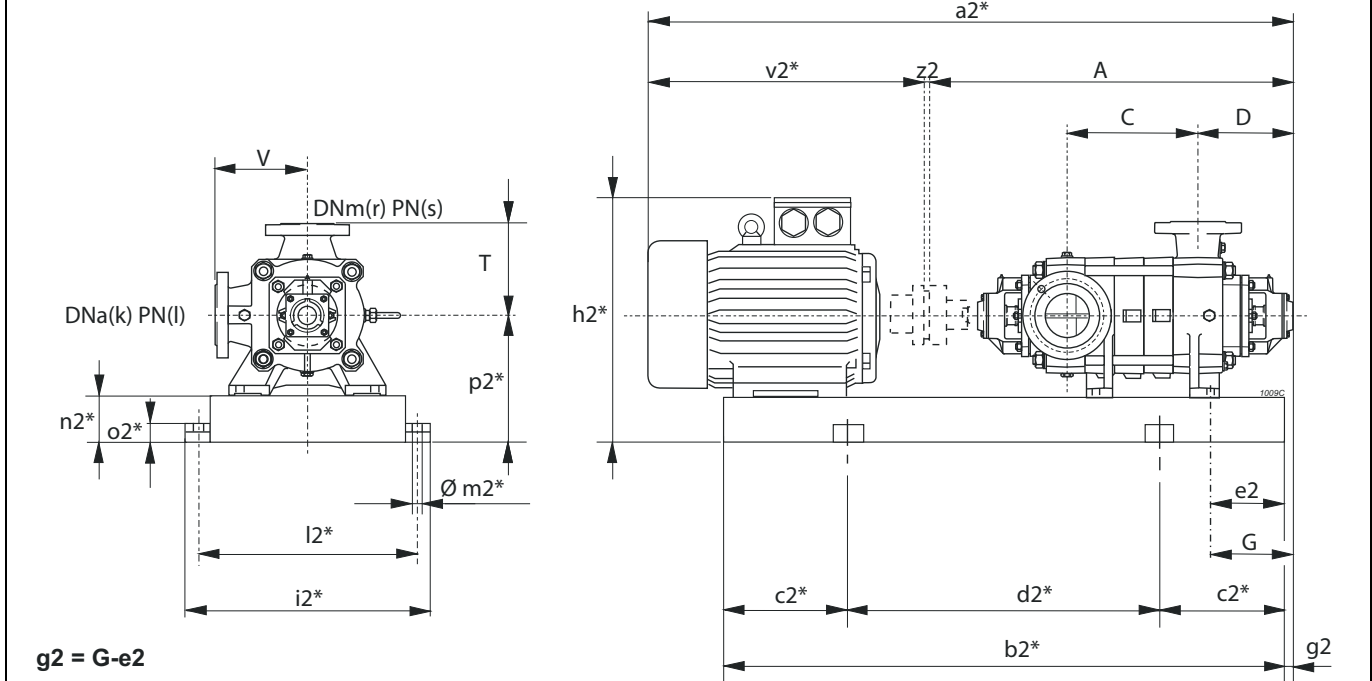

$g2 = G - e2$

* Valori indicativi in funzione della marca di motore utilizzato
 Indicatives values according to the type of motor installed

Pump Pompe Pompa	Motor Moteur Motore	BGAM	A	C	D	G	T	V	a2*	b2*	c2*	d2*	e2	h2*	i2*	k	l	l2*	m2*	n2*	o2*	p2*	r	s	v2*	z2	Weight Poids Peso		
Series Série Serie	Type Type Tipo	[kW]	Size Taille Grand.	Type Type Tipo	[mm]																				[kg]				
PMX(S)T	50/2	1,1	90S	951/CL	652,5	137	227	197	195	195	1011,5	741	100	541	40	418	500	65	25	450	20	100	42	280	50	(2)	355	4	153
PMX(S)T	/2	1,5	90L	915/CL	652,5	137	227	197	195	195	1041,5	766	150	466	40	418	500	65	25	450	20	100	42	280	50	(2)	385	4	158
PMX(S)T	/2	2,2	100L	9917/CL	652,5	137	227	197	195	195	1061,5	801	150	501	40	430	500	65	25	450	20	100	42	280	50	(2)	405	4	171
PMX(S)T	50/3	1,5	90L	916/CL	712,5	197	227	197	195	195	1101,5	826	150	526	40	418	500	65	25	450	20	100	42	280	50	(2)	385	4	171
PMX(S)T	/3	2,2	100L	917/CL	712,5	197	227	197	195	195	1121,5	861	150	561	40	430	500	65	25	450	20	100	42	280	50	(2)	405	4	184
PMX(S)T	/3	3	100L	917/CL	712,5	197	227	197	195	195	1121,5	861	150	561	40	430	500	65	25	450	20	100	42	280	50	(2)	405	4	188
PMX(S)T	50/4	2,2	100L	918/CL	772,5	257	227	197	195	195	1181,5	921	150	621	40	430	500	65	25	450	20	100	42	280	50	(2)	405	4	197
PMX(S)T	/4	3	100L	918/CL	772,5	257	227	197	195	195	1181,5	921	150	621	40	430	500	65	25	450	20	100	42	280	50	(2)	405	4	201
PMX(S)T	/4	4	112M	919/CL	772,5	257	227	197	195	195	1216,5	928	150	628	40	452	500	65	25	450	20	100	42	280	50	(2)	440	4	203
PMX(S)T	50/5	3	100L	920/CL	832,5	317	227	197	195	195	1241,5	981	150	681	40	430	500	65	25	450	20	100	42	280	50	(2)	405	4	214
PMX(S)T	/5	4	112M	921/CL	832,5	317	227	197	195	195	1276,5	988	150	688	40	452	500	65	25	450	20	100	42	280	50	(2)	440	4	216
PMX(S)T	/5	5,5	132S	922/DL	832,5	317	227	197	195	195	1291,5	1049	150	749	40	472	500	65	25	450	20	100	42	280	50	(2)	455	4	226
PMX(S)T	50/6	3	100L	923/CL	892,5	377	227	197	195	195	1301,5	1041	150	741	40	430	500	65	25	450	20	100	42	280	50	(2)	405	4	228
PMX(S)T	/6	4	112M	924/CL	892,5	377	227	197	195	195	1336,5	1048	150	748	40	452	500	65	25	450	20	100	42	280	50	(2)	440	4	229
PMX(S)T	/6	5,5	132S	925/DL	892,5	377	227	197	195	195	1351,5	1109	200	709	40	472	500	65	25	450	20	100	42	280	50	(2)	455	4	239
PMX(S)T	50/7	4	112M	926/CL	952,5	437	227	197	195	195	1396,5	1108	200	708	40	452	500	65	25	450	20	100	42	280	50	(2)	440	4	242
PMX(S)T	/7	5,5	132S	927/DL	952,5	437	227	197	195	195	1411,5	1169	200	769	40	472	500	65	25	450	20	100	42	280	50	(2)	455	4	252
PMX(S)T	/7	7,5	132M	928/DL	952,5	437	227	197	195	195	1446,5	1207	200	807	40	472	500	65	25	450	20	100	42	280	50	(2)	490	4	261
PMX(S)T	50/8	4	112M	929/CL	1012,5	497	227	197	195	195	1456,5	1168	200	768	40	452	500	65	25	450	20	100	42	280	50	(2)	440	4	256
PMX(S)T	/8	5,5	132S	930/DL	1012,5	497	227	197	195	195	1471,5	1229	200	829	40	472	500	65	25	450	20	100	42	280	50	(2)	455	4	266
PMX(S)T	/8	7,5	132M	931/DL	1012,5	497	227	197	195	195	1506,5	1267	200	867	40	472	500	65	25	450	20	100	42	280	50	(2)	490	4	274
PMX(S)T	50/9	5,5	132S	932/DL	1072,5	557	227	197	195	195	1531,5	1289	200	889	40	472	500	65	25	450	20	100	42	280	50	(2)	455	4	279
PMX(S)T	/9	7,5	132M	933/DL	1072,5	557	227	197	195	195	1566,5	1327	200	927	40	472	500	65	25	450	20	100	42	280	50	(2)	490	4	287
PMX(S)T	/9	11	160M	952/EM	1072,5	557	227	197	195	195	1703,5	1413	250	913	40	531	500	65	25	450	20	100	42	280	50	(2)	627	4	374
PMX(S)T	50/10	5,5	132S	934/DL	1132,5	617	227	197	195	195	1591,5	1349	200	949	40	472	500	65	25	450	20	100	42	280	50	(2)	455	4	292
PMX(S)T	/10	7,5	132M	935/DL	1132,5	617	227	197	195	195	1626,5	1387	250	887	40	472	500	65	25	450	20	100	42	280	50	(2)	490	4	301
PMX(S)T	/10	11	160M	936/EM	1132,5	617	227	197	195	195	1763,5	1473	250	973	40	531	500	65	25	450	20	100	42	280	50	(2)	627	4	387
PMX(S)T	50/11	7,5	132M	937/DL	1192,5	677	227	197	195	195	1686,5	1447	250	947	40	472	500	65	25	450	20	100	42	280	50	(2)	490	4	314
PMX(S)T	/11	11	160M	938/EM	1192,5	677	227	197	195	195	1823,5	1533	250	1033	40	531	500	65	25	450	20	100	42	280	50	(2)	627	4	400
PMX(S)T	50/12	7,5	132M	939/DL	1252,5	737	227	197	195	195	1746,5	1507	250	1007	40	472	500	65	25	450	20	100	42	280	50	(2)	490	4	327
PMX(S)T	/12	11	160M	940/EM	1252,5	737	227	197	195	195	1883,5	1593	250	1093	40	531	500	65	25	450	20	100	42	280	50	(2)	627	4	413
PMX(S)T	/12	15	160L	941/EM	1252,5	737	227	197	195	195	1883,5	1637	250	1137	40	531	500	65	25	450	20	100	42	280	50	(2)	627	4	426
PMX(S)T	50/13	7,5	132M	942/DL	1312,5	797	227	197	195	195	1806,5	1567	250	1067	40	472	500	65	25	450	20	100	42	280	50	(2)	490	4	341

BGAM = Base and coupling
 * = Indicatives values according to the type of motor installed.
 (2) PMXT=40 bar PMXST=63 bar

BGAM = Socle et accouplement
 * = Valeurs indicatives en fonction de la marque du moteur utilisé.
 (2) PMXT=40 bar PMXST=63 bar

BGAM = Base giunto e coprigiunto
 * = Valori indicativi in funzione della marca di motore utilizzato.
 (2) PMXT=40 bar PMXST=63 bar

Selection - dimensions and weights for base mounted electric pumps
 Sélection - dimensions et poids des électropompes sur socle
 Selezione - dimensioni e pesi elettropompe su base

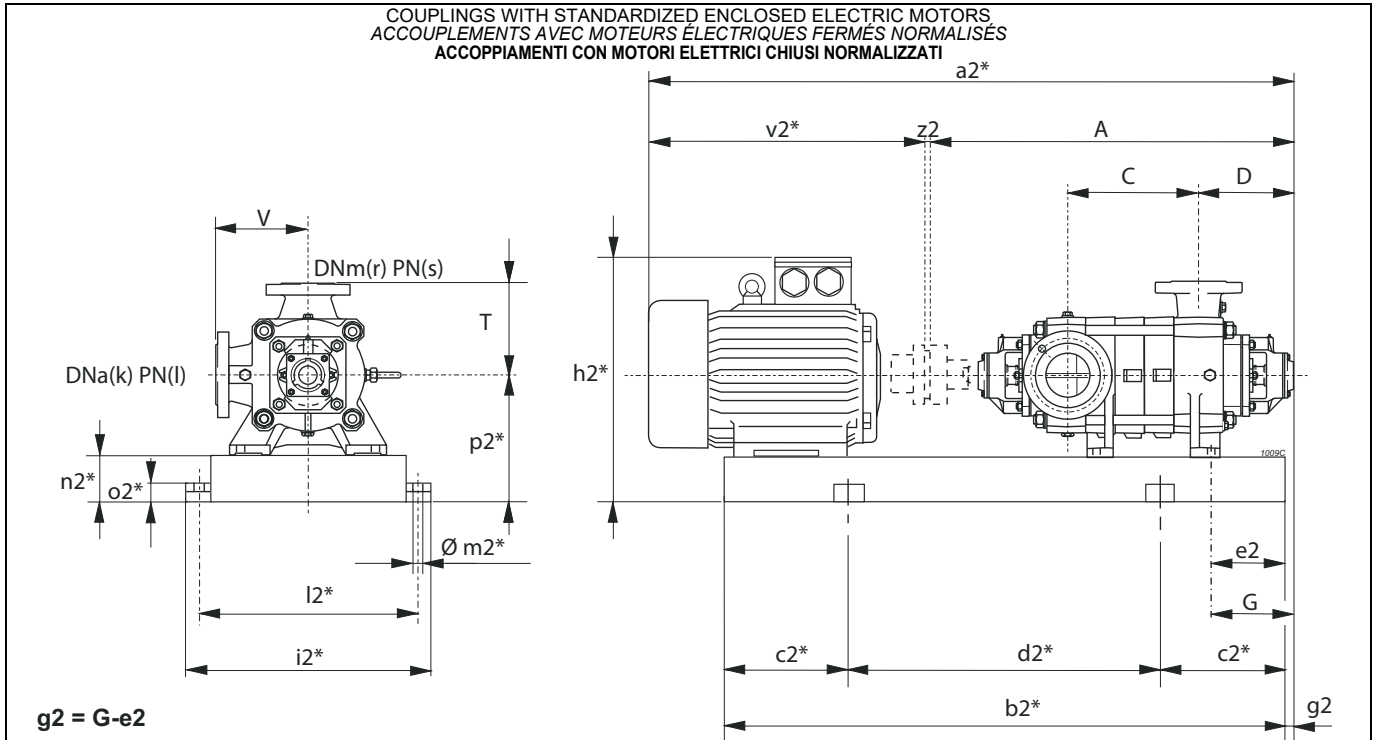

* Valori indicativi in funzione della marca di motore utilizzato
 Indicatives values according to the type of motor installed

Pump Pompe Pompa		Motor Moteur Motore		BGAM	A	C	D	G	T	V	a2*	b2*	c2*	d2*	e2	h2*	i2*	k	l	l2*	m2*	n2*	o2*	p2*	r	s	v2*	z2	Weight Poids Peso
Series Série Serie	Type Type Tipo	[kW]	Size Taille Grand.	Type Type Tipo	[mm]																								[kg]
PMX(S)T	/13	11	160M	943/EM	1312,5	797	227	197	195	195	1943,5	1653	300	1053	40	531	500	65	25	450	20	100	42	280	50	(2)	627	4	427
PMX(S)T	/13	15	160L	944/EM	1312,5	797	227	197	195	195	1943,5	1697	300	1097	40	531	500	65	25	450	20	100	42	280	50	(2)	627	4	440
PMX(S)T	50/14	7,5	132M	945/DL	1372,5	857	227	197	195	195	1866,5	1627	250	1127	40	472	500	65	25	450	20	100	42	280	50	(2)	490	4	354
PMX(S)T	/14	11	160M	946/EM	1372,5	857	227	197	195	195	2003,5	1713	300	1113	40	531	500	65	25	450	20	100	42	280	50	(2)	627	4	440
PMX(S)T	/14	15	160L	947/EM	1372,5	857	227	197	195	195	2003,5	1757	300	1157	40	531	500	65	25	450	20	100	42	280	50	(2)	627	4	453
PMX(S)T	50/15	11	160M	949/EM	1432,5	917	227	197	195	195	2063,5	1773	300	1173	40	531	500	65	25	450	20	100	42	280	50	(2)	627	4	453
PMX(S)T	/15	15	160L	950/EM	1432,5	917	227	197	195	195	2063,5	1817	300	1217	40	531	500	65	25	450	20	100	42	280	50	(2)	627	4	466

BGAM = Base and coupling

* = Indicatives values according to the type of motor installed.

(2) PMXT=40 bar PMXST=63 bar

BGAM = Socle et accouplement

* = Valeurs indicatives en fonction de la marque du moteur utilisé.

(2) PMXT=40 bar PMXST=63 bar

BGAM = Base giunto e coprigiunto

* = Valori indicativi in funzione della marca di motore utilizzato.

(2) PMXT=40 bar PMXST=63 bar