

Electric pump type <i>Electropompe type</i> Elettropompa tipo	Impeller type <i>Roue type</i> Girante tipo	Capacity <i>Debit</i> Portata															
		[l/m]	240	300	360	420	480	540	600	1200	1800	2400	3000	3600	4200	4800	5400
		[m³/h]	14	18	22	25	29	32	36	72	108	144	180	216	252	288	324
		[l/s]	4	5	6	7	8	9	10	20	30	40	50	60	70	80	90
		Total manometric head <i>Hauteur manometrique totale</i> Prevalenza manometrica totale															
SCC-2-100-400	A	[m]		58,7	58,7	58,7	58,7	58,7	58,7	58,6	58,2	57,1	55,1	52	47,7	42,1	35,1
SCC-2-100-400	B	[m]		52,8	52,8	52,8	52,8	52,7	52,7	52,7	51,5	49,5	46,2	41,3	34,9		
SCC-2-100-400	C	[m]	43,4	43,4	43,4	43,3	43,3	43,3	43,3	43,2	42,7	41	37,8	32,9	26,3		
SCC-2-100-400	D	[m]	35,7	35,7	35,7	35,7	35,7	35,7	35,7	35,5	34,3	31,4	26,6	20,1			
NPSH		[m]		1,8	1,8	1,8	1,8	1,8	1,8	1,8	1,9	2	2,3	2,9	3,8	5,2	7,1

Overall dimensions and weights  
 Dimensions d'encombrement et poids  
 Dimensioni di ingombro e pesi

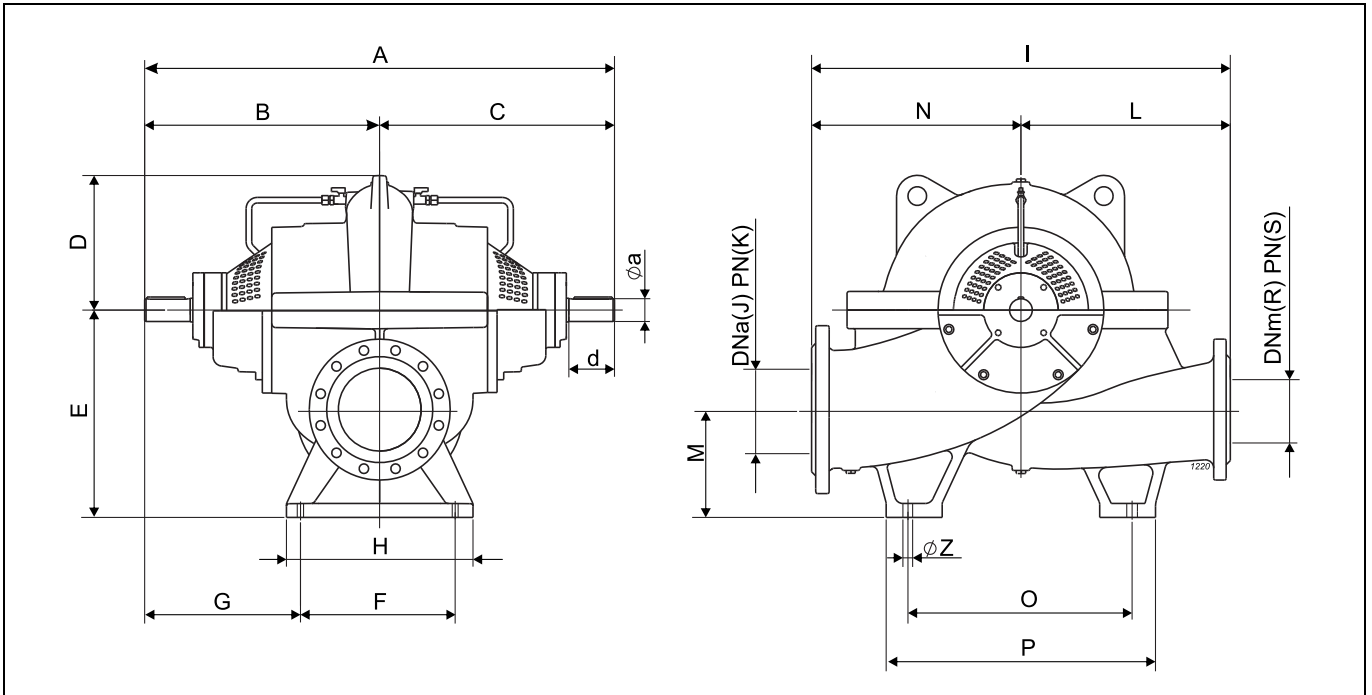

Type Type Tipo	Weight Poids Peso	A	B	C	D	E	F	G	H	I	J	K	L	M	N	O	P	R	S	Z	a	d
		[mm]																				
SCC-2-65-250	157	796	398	398	210	300	230	283	300	600	100	16	280	160	320	380	467	65	16	20	35	75
SCC-2-80-250	162	796	398	398	226	300	233	280	303	599	125	16	280	160	319	405	469	80	16	20	35	75
SCC-2-80-315	200	796	398	398	270	300	225	283,5	300	660	125	16	300	160	360	400	488	80	16	20	35	75
SCC-2-100-250	223	895	447,5	447,5	234	355	281	307	340	670	150	16	310	185	360	400	483	100	16	20	42	90
SCC-2-100-315	230	895	447,5	447,5	252	355	275	309	340	670	150	16	310	185	360	400	485	100	16	20	42	90
SCC-2-100-400	303	895	447,5	447,5	303	355	280	307,5	340	790	150	16	370	185	420	460	560	100	16	20	42	90
SCC-2-125-315	360	1052	526	526	284	400	320	366	380	790	200	16	370	200	420	460	540	125	16	22	55	110
SCC-2-125-350	402	1052	526	526	310	400	320	366	380	920	200	16	450	200	470	540	660	125	16	22	55	110
SCC-2-125-480	400	983	491,5	491,5	308	400	340	321,5	390	900	200	16	450	200	450	560	640	125	16	22	42	90
SCC-2-150-315	400	1052	526	526	319	400	320	366	380	870	200	16	400	200	470	540	643	150	16	22	55	110
SCC-2-150-460	430	1090	545	545	305	400	320	385	380	900	200	16	450	200	450	540	640	150	16	22	55	110
SCC-2-150-600	780	1284	642	642	437	560	320	482	420	1050	250	25	500	260	550	640	640	150	25	22	65	130
SCC-2-200-315	590	1284	642	642	337	500	360	462	420	950	250	16	450	260	500	540	643	200	16	22	65	130
SCC-2-200-430	630	1132	566	566	317	500	360	386	450	1000	250	16	500	260	500	540	650	200	16	24	55	110
SCC-2-200-500	690	1284	642	642	377	560	360	462	420	1050	250	16	500	260	550	620	724	200	16	22	65	130
SCC-2-250-350	680	1284	642	642	399	600	356	464	420	1100	300	16	500	300	600	620	724	250	16	30	65	130
SCC-2-250-450	780	1284	642	642	424	600	360	462	420	1100	300	16	500	300	600	620	720	250	16	23	65	130
SCC-2-250-600	1050	1440	720	720	441	600	405	517,5	485	1200	300	25	550	300	650	620	715	250	25	26	80	170
SCC-2-300-315	700	1284	642	642	400	630	348	468	420	1100	350	16	500	330,03	600	620	700	300	16	24	65	130
SCC-2-300-400	930	1328	664	664	365	630	420	454	520	1190	400	16	560	310	630	680	800	300	16	26	60	140
SCC-2-300-500	1500	1519	759,5	759,5	436	710	410	554,5	520	1450	400	16	750	360	700	700	809	300	16	26	80	170
SCC-2-300-700	1650	1731	865,5	865,5	489	710	410	660,5	520	1550	400	25	800	360	750	720	880	300	25	26,5	100	180
SCC-2-350-350	1120	1544	772	772	449	670	420	562	520	1250	400	16	550	320	700	720	804	350	16	26	75	140
SCC-2-350-400	1410	1545	772,5	772,5	502	800	500	522,5	600	1400	500	16	600	420	800	800	961	350	16	26	75	140
SCC-2-350-500	1435	1509	754,5	754,5	443	800	498	505,5	600	1400	500	16	600	400	800	740	910	350	16	26	80	170
SCC-2-350-700	2000	1731	865,5	865,5	534	850	498	616,5	600	1600	500	25	750	400	850	720	890	350	25	26	100	180

Selection - dimensions and weights for base mounted electric pumps  
 Sélection - dimensions et poids des électropompes sur socle  
 Selezione - dimensioni e pesi elettropompe su base

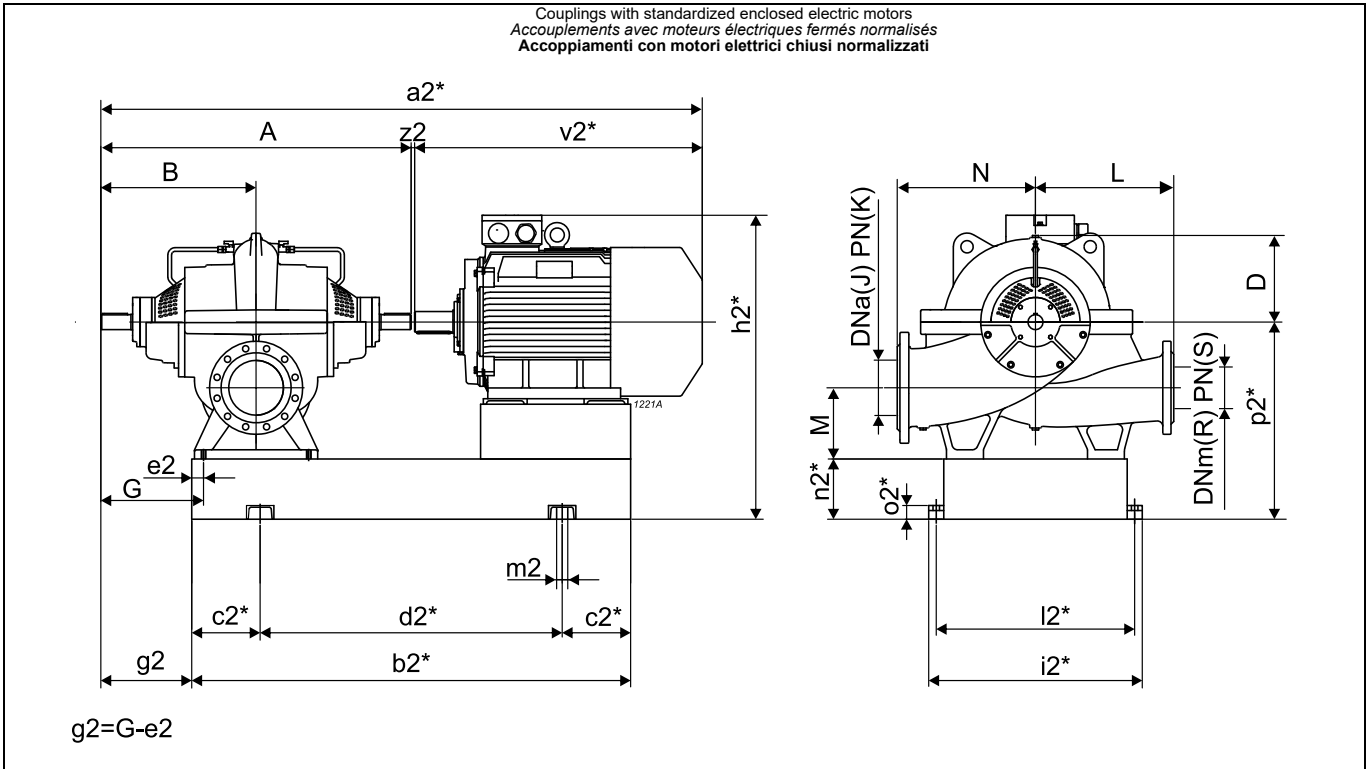

Pump Pompe Pompa	Motor Moteur Motore		Weight Poids Peso	BGAC2	A	B	D	G	J	K	L	M	N	R	S	a2*	b2*	c2*	d2*	e2	h2*	i2*	l2*	m2	n2*	o2*	p2*	v2*	z2		
	Type Type Tipo	[kW]			Size Taille Grand.	[kg]	[mm]																								
SCC-2-65-250	4	112M	293	65-250-4	796	398	210	283	100	16	280	160	320	65	16	1240	894	150	594	55	632	597	547	22	160	50	460	440	4		
SCC-2-65-250	5,5	132S	300	65-250-5,5	796	398	210	283	100	16	280	160	320	65	16	1255	933	150	633	55	652	597	547	22	160	50	460	455	4		
SCC-2-65-250	7,5	132M	311	65-250-7,5	796	398	210	283	100	16	280	160	320	65	16	1290	971	150	671	55	652	597	547	22	160	50	460	490	4		
SCC-2-65-250	11	160M	403	65-250-11	796	398	210	283	100	16	280	160	320	65	16	1427	1082	200	682	55	711	597	547	22	160	50	460	627	4		
SCC-2-65-250	15	160L	417	65-250-15	796	398	210	283	100	16	280	160	320	65	16	1427	1126	200	726	55	711	597	547	22	160	50	460	627	4		
SCC-2-80-250	7,5	132M	316	80-250-7,5	796	398	226	280	125	16	280	160	319	80	16	1290	968	150	668	55	652	599	549	22	160	50	460	490	4		
SCC-2-80-250	11	160M	408	80-250-11	796	398	226	280	125	16	280	160	319	80	16	1427	1079	200	679	55	711	599	549	22	160	50	460	627	4		
SCC-2-80-250	15	160L	421	80-250-15	796	398	226	280	125	16	280	160	319	80	16	1427	1123	200	723	55	711	599	549	22	160	50	460	627	4		
SCC-2-80-315	15	160L	462	80-315-15	796	398	270	283,5	125	16	300	160	360	80	16	1427	1123	200	723	58	711	620	570	22	160	50	460	627	4		
SCC-2-80-315	18,5	180M	498	80-315-18,5	796	398	270	283,5	125	16	300	160	360	80	16	1465	1133	200	733	58	730	620	570	22	160	50	460	665	4		
SCC-2-80-315	22	180L	520	80-315-22	796	398	270	283,5	125	16	300	160	360	80	16	1505	1171	200	771	58	730	620	570	22	160	50	460	705	4		
SCC-2-80-315	30	200L	575	80-315-30	796	398	270	283,5	125	16	300	160	360	80	16	1558	1189	200	789	58	760	620	570	22	160	50	460	758	4		
SCC-2-100-250	7,5	132M	400	100-250-7,5	895	447,5	234	307	150	16	310	185	360	100	16	1389	1041	150	741	48	727	607	557	22	180	50	535	490	4		
SCC-2-100-250	11	160M	489	100-250-11	895	447,5	234	307	150	16	310	185	360	100	16	1526	1132	200	732	48	786	607	557	22	180	50	535	627	4		
SCC-2-100-250	15	160L	506	100-250-15	895	447,5	234	307	150	16	310	185	360	100	16	1526	1176	200	776	48	786	607	557	22	180	50	535	627	4		
SCC-2-100-250	18,5	180M	557	100-250-18,5	895	447,5	234	307	150	16	310	185	360	100	16	1564	1216	200	816	48	805	607	557	22	180	50	535	665	4		
SCC-2-100-250	22	180L	578	100-250-22	895	447,5	234	307	150	16	310	185	360	100	16	1604	1254	200	854	48	805	607	557	22	180	50	535	705	4		
SCC-2-100-315	15	160L	513	100-315-15	895	447,5	252	309	150	16	310	185	360	100	16	1526	1176	200	776	48	786	610	560	22	180	50	535	627	4		
SCC-2-100-315	18,5	180M	564	100-315-18,5	895	447,5	252	309	150	16	310	185	360	100	16	1564	1216	200	816	48	805	610	560	22	180	50	535	665	4		
SCC-2-100-315	22	180L	585	100-315-22	895	447,5	252	309	150	16	310	185	360	100	16	1604	1254	200	854	48	805	610	560	22	180	50	535	705	4		
SCC-2-100-315	30	200L	641	100-315-30	895	447,5	252	309	150	16	310	185	360	100	16	1657	1282	200	882	48	835	610	560	22	180	50	535	758	4		
SCC-2-100-400	30	200L	724	100-400-30	895	447,5	303	307,5	150	16	370	185	420	100	16	1657	1282	200	882	50	835	690	640	22	180	50	535	758	4		
SCC-2-100-400	37	225S	762	100-400-37	895	447,5	303	307,5	150	16	370	185	420	100	16	1692	1309	200	909	50	865	690	640	22	180	50	535	793	4		
SCC-2-100-400	45	225M	806	100-400-45	895	447,5	303	307,5	150	16	370	185	420	100	16	1717	1334	200	934	50	865	690	640	22	180	50	535	818	4		
SCC-2-100-400	55	250M	979	100-400-55	895	447,5	303	307,5	150	16	370	185	420	100	16	1779	1411	250	911	50	910	690	640	22	180	50	535	880	4		
SCC-2-100-400	75	280S	1078	100-400-75	895	447,5	303	307,5	150	16	370	185	420	100	16	1912	1452	250	952	50	930	690	640	22	180	50	535	1013	4		
SCC-2-125-315	18,5	180M	709	125-315-18,5	1052	526	284	366	200	16	370	200	420	125	16	1721	1271	200	871	50	870	670	620	22	200	50	600	665	4		
SCC-2-125-315	22	180L	733	125-315-22	1052	526	284	366	200	16	370	200	420	125	16	1761	1309	200	909	50	870	670	620	22	200	50	600	705	4		
SCC-2-125-315	30	200L	797	125-315-30	1052	526	284	366	200	16	370	200	420	125	16	1814	1347	200	947	50	900	670	620	22	200	50	600	758	4		
SCC-2-125-315	37	225S	856	125-315-37	1052	526	284	366	200	16	370	200	420	125	16	1849	1414	250	914	50	930	670	620	22	200	50	600	793	4		

BGAC2 = Base and coupling

\* = Indicatives values according to the type of motor installed.

o Motor in IE4 efficiency class according to EU REGULATION 2019/1781. Available in other efficiency classes for non-EU markets.

BGAC2 = Socle et accouplement

\* = Valeurs indicatives en fonction de la marque du moteur utilisé.

o Moteur en classe de rendement IE4 conformément au RÈGLEMENT UE2019/1781. Disponibilit  en diff rentes classes de rendement pour les march s hors UE.

BGAC2 = Base e giunto

\* = Valori indicativi in funzione della marca di motore utilizzato.

o Motore in classe di efficienza IE4 in conformit  al REGOLAMENTO UE2019/1781. Disponibili in altre classi di efficienza per mercati extra UE.