

Overall dimensions and weights
Dimensions d'encombrement et poids
Dimensioni di ingombro e pesi

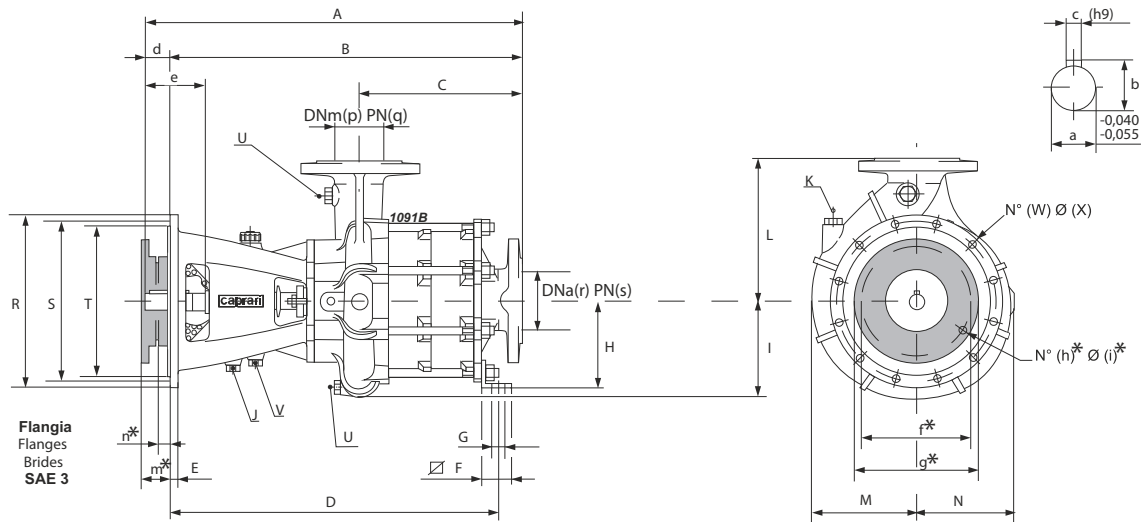

*Dimensioni variabili in funzione della grandezza giunto
*Variable dimensions according to coupling's size

Type Type Tipo	Weight Poids Peso [kg]	A	B	C	D	E	F	G	H	I	J	K	L	M	N	R	S	T	U	V	W	X	p	q	r	s
		[mm]																								
MEC-MG 80/2	127	659	639	250	-	20	-	-	-	223	G 3/8"	G 3/8"	325	244	225,5	451	428,625	409,575	G 3/8"	G 1/2"	12	11,5	80	16	100	16
MEC-MG 80/3	158	754	734	345	672	20	45	28	200	223	G 3/8"	G 3/8"	325	244	225,5	451	428,625	409,575	G 3/8"	G 1/2"	12	11,5	80	16	100	16
MEC-MG 80-4/3	158	754	734	345	672	20	45	28	200	223	G 3/8"	G 3/8"	325	244	225,5	451	428,625	409,575	G 3/8"	G 1/2"	12	11,5	80	16	100	16
MEC-MG 80-4/4	215	849	829	440	767	20	45	28	200	223	G 3/8"	G 3/8"	325	244	225,5	451	428,625	409,575	G 3/8"	G 1/2"	12	11,5	80	16	100	16
MEC-MG 100/3	312	907	887	415	839	20	65	24	280	286	G 3/8"	G 3/8"	400	285	263	451	428,625	409,575	G 3/8"	G 1/2"	12	11,5	100	16	125	16
MEC-MG 100-1/2	253	777	757	286	-	20	-	-	-	286	G 3/8"	G 3/8"	400	285	263	451	428,625	409,575	G 3/8"	G 1/2"	12	11,5	100	16	100	16
MEC-MG 100-1/3	312	907	887	415	839	20	65	24	280	286	G 3/8"	G 3/8"	400	285	263	451	428,625	409,575	G 3/8"	G 1/2"	12	11,5	100	16	100	16
MEC-MG 100-2/2	253	777	757	286	-	20	-	-	-	286	G 3/8"	G 3/8"	400	285	263	451	428,625	409,575	G 3/8"	G 1/2"	12	11,5	100	16	125	16
MEC-MG 100-2/3	312	907	887	415	839	20	65	24	280	286	G 3/8"	G 3/8"	400	285	263	451	428,625	409,575	G 3/8"	G 1/2"	12	11,5	100	16	125	16

Shaft projection Saille d'arbre Sporgenza d'albero					
Type Type Tipo	a	b	c	d	e
[mm]					
MEC-MG 80...	35	38	10	20	86
MEC-MG 100...	45	48,5	14	20	101

Coupling Accouplement Giunto									
Pump type Pompe type Pompa tipo	Type Type Tipo	Size Taille Grand.	Weight Poids Peso [kg]	f*	g*	h*	i*	m*	n*
[mm]									
MEC-MG80...	G220.08.35 I	8"	13	244,475	263,525	6	11,5	62	33
	G220.10.35 I	10"	14	295,275	314,325	8	11,5	54	25
	G250.11.35.I	11½"	28,8	333,375	352,425	8	11,5	40	6,5
MEC-MG100...	G220.08.45 I	8"	12,5	244,475	263,525	6	11,5	62	33
	G220.10.45 I	10"	14	295,275	314,325	8	11,5	54	25
	G250.11.45.I	11½"	20,5	333,375	352,425	8	11,5	40	6,5

Overall dimensions and weights
 Dimensions d'encombrement et poids
 Dimensioni di ingombro e pesi

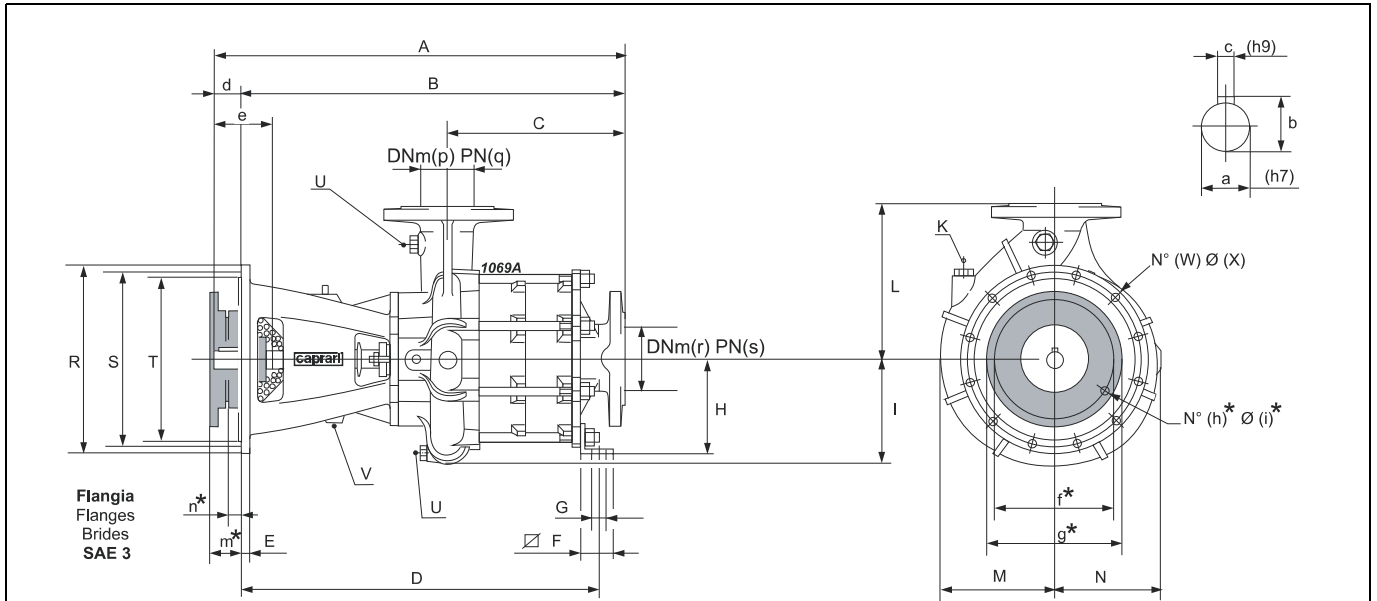

*Dimensioni variabili in funzione della grandezza giunto
 *Variable dimensions according to coupling's size

Type Type Tipo	Weight Poids Peso	A	B	C	D	E	F	G	H	I	K	L	M	N	R	S	T	U	V	W	X	p	q	r	s
		[mm]																							
MEC-MG 100HT-1/2	248	778	758	286	713	20	70	32	280	286	G 3/8"	400	285	263	451	428,625	409,575	G 3/8"	G 1/2"	12	11,5	100	16	125	16
MEC-MG 125HT-1/2	264	786	766	295	718	20	70	32	280	294	G 3/8"	425	303	270	451	428,625	409,575	G 3/8"	G 1/2"	12	11,5	125	16	150	16

Shaft projection Saïlle d'arbre Sporgenza d'albero					
Type Type Tipo	a	b	c	d	e
	[mm]				
MEC-MG 100	50	52,5	14	20,2	93
MEC-MG 125	50	52,5	14	20,2	93

Coupling Accouplement Giunto									
Pump type Pompe type Pompa tipo	Type Type Tipo	Size Taille Grand.	Weight Poids Peso	f*	g*	h*	i*	m*	n*
			[kg]	[mm]					
MEC-MG100... MEC-MG125...	G220.08.50.I	8"	0	244,475	263,525	6	11,5	62	33
	G220.10.50.I	10"	0	295,275	314,325	8	11,5	54	25
	G250.11.50.I	11½"	20,3	333,375	352,425	8	11,5	40	6,5

Overall dimensions and weights
Dimensions d'encombrement et poids
Dimensioni di ingombro e pesi

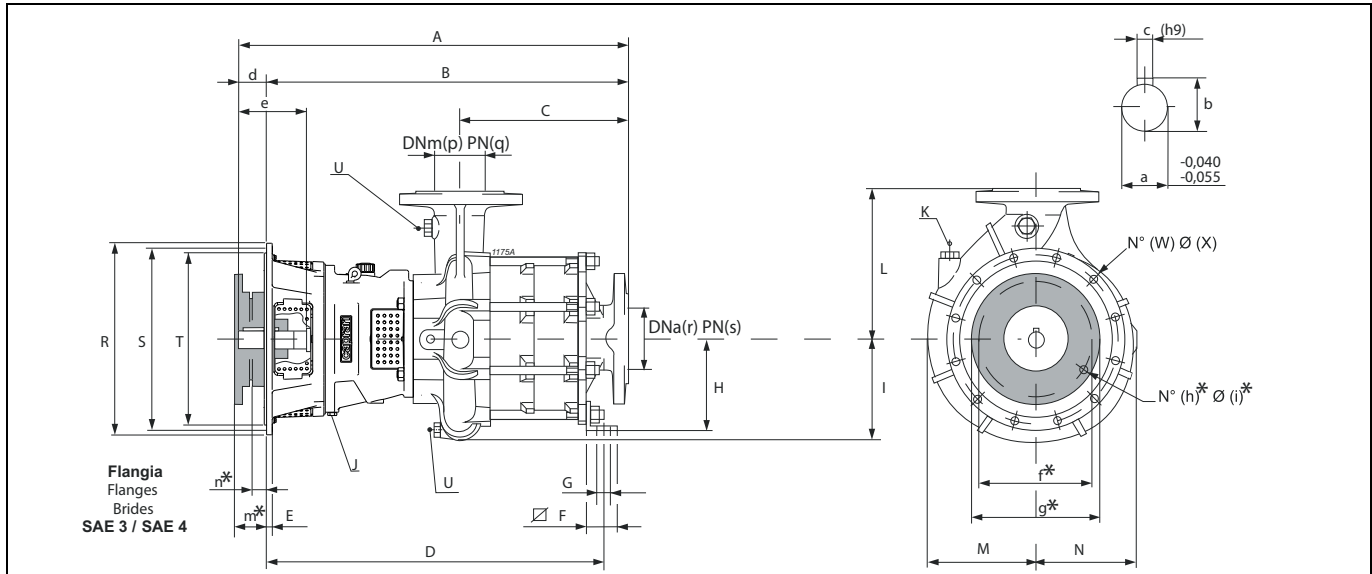

*Dimensioni variabili in funzione della grandezza giunto
*Variable dimensions according to coupling's size

Type Type Tipo	Weight Poids Peso	A	B	C	D	E	F	G	H	I	J	K	L	M	N	R	S	T	U	W	X	p	q	r	s
		[kg]	[mm]																						
MEC-MG 65-1H3/3	144.5	684,8	664,8	275,8	628,8	12	45	28	160	201,5	G 3/8"	G 3/8"	275	201,5	201,5	450,8	428,6	409,6	G 3/8"	12	11	65	25	80	16
MEC-MG 65-1H3/4	162.5	762,6	742,6	353,6	706,6	12	45	28	160	201,5	G 3/8"	G 3/8"	275	201,5	201,5	450,8	428,6	409,6	G 3/8"	12	11	65	25	80	16
MEC-MG 65-1H4/3	141	684,8	664,8	275,8	628,8	12	45	28	160	201,5	G 3/8"	G 3/8"	275	201,5	201,5	403	381	362	G 3/8"	12	11	65	25	80	16
MEC-MG 65-1H4/4	159	762,6	742,6	353,6	706,6	12	45	28	160	201,5	G 3/8"	G 3/8"	275	201,5	201,5	403	381	362	G 3/8"	12	11	65	25	80	16
MEC-MG 65-2H3/3	144.5	684,8	664,8	275,8	628,8	12	45	28	160	201,5	G 3/8"	G 3/8"	275	201,5	201,5	450,8	428,6	409,6	G 3/8"	12	11	65	25	80	16
MEC-MG 65-2H3/4	162.5	762,6	742,6	353,6	706,6	12	45	28	160	201,5	G 3/8"	G 3/8"	275	201,5	201,5	450,8	428,6	409,6	G 3/8"	12	11	65	25	80	16
MEC-MG 65-2H4/3	141	684,8	664,8	275,8	628,8	12	45	28	160	201,5	G 3/8"	G 3/8"	275	201,5	201,5	403	381	362	G 3/8"	12	11	65	25	80	16
MEC-MG 65-2H4/4	159	762,6	742,6	353,6	706,6	12	45	28	160	201,5	G 3/8"	G 3/8"	275	201,5	201,5	403	381	362	G 3/8"	12	11	65	25	80	16
MEC-MG 65-3H3/3	144.5	684,8	664,8	275,8	628,8	12	45	28	160	201,5	G 3/8"	G 3/8"	275	201,5	201,5	450,8	428,6	409,6	G 3/8"	12	11	65	25	80	16
MEC-MG 65-3H3/4	162.5	762,6	742,6	353,6	706,6	12	45	28	160	201,5	G 3/8"	G 3/8"	275	201,5	201,5	450,8	428,6	409,6	G 3/8"	12	11	65	25	80	16
MEC-MG 65-3H4/3	141	684,8	664,8	275,8	628,8	12	45	28	160	201,5	G 3/8"	G 3/8"	275	201,5	201,5	403	381	362	G 3/8"	12	11	65	25	80	16
MEC-MG 65-3H4/4	159	762,6	742,6	353,6	706,6	12	45	28	160	201,5	G 3/8"	G 3/8"	275	201,5	201,5	403	381	362	G 3/8"	12	11	65	25	80	16
MEC-MG 80H3/2	114.5	657,6	637,6	248,6	-	12	-	-	-	224	G 3/8"	G 3/8"	325	244	222	403	381	362	G 3/8"	12	11	80	16	100	16
MEC-MG 80H3/3	145.5	752,4	732,4	343,4	670,4	12	45	28	200,65	224	G 3/8"	G 3/8"	325	244	222	403	381	362	G 3/8"	12	11	80	16	100	16
MEC-MG 80H4/2	114.5	657,6	637,6	248,6	-	12	-	-	-	224	G 3/8"	G 3/8"	325	244	222	403	381	362	G 3/8"	12	11	80	16	100	16
MEC-MG 80H4/3	145.5	752,4	732,4	343,4	670,4	12	45	28	200,65	224	G 3/8"	G 3/8"	325	244	222	403	381	362	G 3/8"	12	11	80	16	100	16
MEC-MG 80-4H3/3	145.5	752,4	732,4	343,4	670,4	12	45	28	200,65	224	G 3/8"	G 3/8"	325	244	222	403	381	362	G 3/8"	12	11	80	16	100	16
MEC-MG 80-4H3/4	202.5	847,2	827,2	438,2	765,2	12	45	28	200,65	224	G 3/8"	G 3/8"	325	244	222	403	381	362	G 3/8"	12	11	80	16	100	16
MEC-MG 80-4H4/3	145.5	752,4	732,4	343,4	670,4	12	45	28	200,65	224	G 3/8"	G 3/8"	325	244	222	403	381	362	G 3/8"	12	11	80	16	100	16
MEC-MG 80-4H4/4	202.5	847,2	827,2	438,2	765,2	12	45	28	200,65	224	G 3/8"	G 3/8"	325	244	222	403	381	362	G 3/8"	12	11	80	16	100	16

Shaft projection Saille d'arbre Sporgenza d'albero					
Type Type Tipo	a	b	c	d	e
	[mm]				
MEC-MG 65H3...	35	38	10	20	86
MEC-MG 65H4...	35	38	10	20	86
MEC-MG 80H3...	35	38	10	20	86
MEC-MG 80H4...	35	38	10	20	86

Coupling Accouplement Giunto									
Pump type Pompe type Pompa tipo	Type Type Tipo	Size Taille Grand.	Weight Poids Peso	f*	g*	h*	i*	m*	n*
			[kg]	[mm]					
MEC-MG65H3...	G220.08.35 I	8"	13	244,475	263,525	6	11,5	62	33
MEC-MG65H4...	G220.10.35 I	10"	14	295,275	314,325	8	11,5	54	25
MEC-MG80H3...	G250.11.35.I	11½"	28,8	333,375	352,425	8	11,5	40	6,5

Overall dimensions and weights
Dimensions d'encombrement et poids
Dimensioni di ingombro e pesi

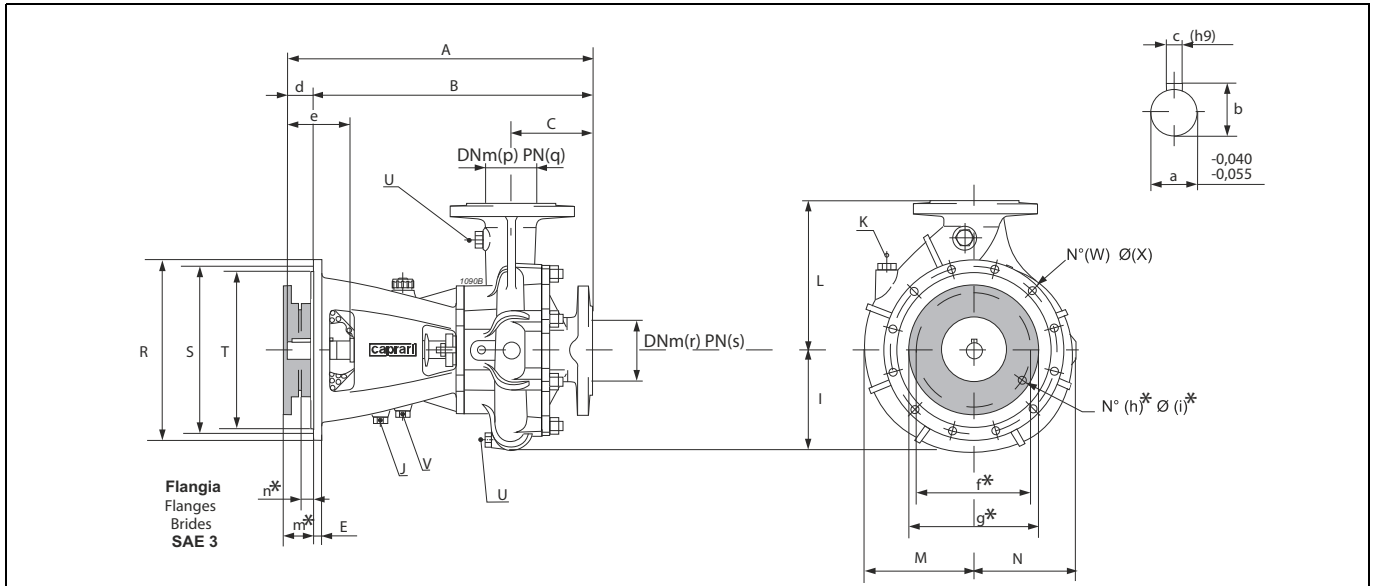

*Dimensioni variabili in funzione della grandezza giunto
*Variable dimensions according to coupling's size

Type Type Tipo	Weight Poids Peso [kg]	A	B	C	E	I	J	K	L	M	N	R	S	T	U	V	W	X	p	q	r	s
		[mm]																				
MEC-AG 3/80	110	557	537	148	20	191	G 3/8"	G 3/8"	300	204	180	451	428,625	409,575	G 3/8"	G 1/2"	12	11,5	80	16	100	16
MEC-AG 4/80	128	562	542	153	20	224	G 3/8"	G 3/8"	325	244	222	451	428,625	409,575	G 3/8"	G 1/2"	12	11,5	80	16	100	16
MEC-AG 2/100	112	556	536	147	20	184	G 3/8"	G 3/8"	275	203	162	451	428,625	409,575	G 3/8"	G 1/2"	12	11,5	100	16	125	16
MEC-AG 3/100	120	556	536	147	20	204	G 3/8"	G 3/8"	300	220	188	451	428,625	409,575	G 3/8"	G 1/2"	12	11,5	100	16	125	16
MEC-AG 4/100	142	566	546	157	20	235	G 3/8"	G 3/8"	375	247	220	451	428,625	409,575	G 3/8"	G 1/2"	12	11,5	100	16	125	16
MEC-AG 5/100	190	647	627	155	20	284	G 3/8"	G 3/8"	400	287	266	451	428,625	409,575	G 3/8"	G 1/2"	12	11,5	100	16	125	16
MEC-AG 1/125	126	573	553	164	20	205	G 3/8"	G 3/8"	300	227	180	451	428,625	409,575	G 3/8"	G 1/2"	12	11,5	125	16	150	16
MEC-AG 2/125	142	564	544	155	20	228	G 3/8"	G 3/8"	350	247	208	451	428,625	409,575	G 3/8"	G 1/2"	12	11,5	125	16	150	16
MEC-AG 3/125	181	655	635	163	20	249	G 3/8"	G 3/8"	375	270	232	451	428,625	409,575	G 3/8"	G 1/2"	12	11,5	125	16	150	16
MEC-AG 4/125	212	655	635	163	20	294	G 3/8"	G 3/8"	425	304	272	451	428,625	409,575	G 3/8"	G 1/2"	12	11,5	125	16	150	16

Shaft projection Saille d'arbre Sporgenza d'albero					
Type Type Tipo	a	b	c	d	e
[mm]					
MEC-AG3/80 MEC-AG4/80 MEC-AG2/100 MEC-AG3/100 MEC-AG4/100 MEC-AG1/125 MEC-AG2/125	35	38	10	20	86
MEC-AG5/100 MEC-AG3/125 MEC-AG4/125	45	48,5	14	20	102

Coupling Accouplement Giunto									
Pump type Pompe type Pompa tipo	Type Type Tipo	Size Taille Grand.	Weight Poids Peso [kg]	f*	g*	h*	i*	m*	n*
[mm]									
MEC-AG3/80 MEC-AG4/80 MEC-AG2/100 MEC-AG3/100 MEC-AG4/100 MEC-AG1/125 MEC-AG2/125	G220.08.35.I	8"	13	244,475	263,525	6	11,5	62	33
	G220.10.35.I	10"	14	295,275	314,325	8	11,5	54	25
	G250.11.35.I	11½"	28,8	333,375	352,425	8	11,5	40	6,5
MEC-AG5/100 MEC-AG3/125 MEC-AG4/125	G220.08.45.I	8"	12,5	244,475	263,525	6	11,5	62	33
	G220.10.45.I	10"	14	295,275	314,325	8	11,5	54	25
	G250.11.45.I	11½"	20,5	333,375	352,425	8	11,5	40	6,5

Overall dimensions and weights
Dimensions d'encombrement et poids
Dimensioni di ingombro e pesi

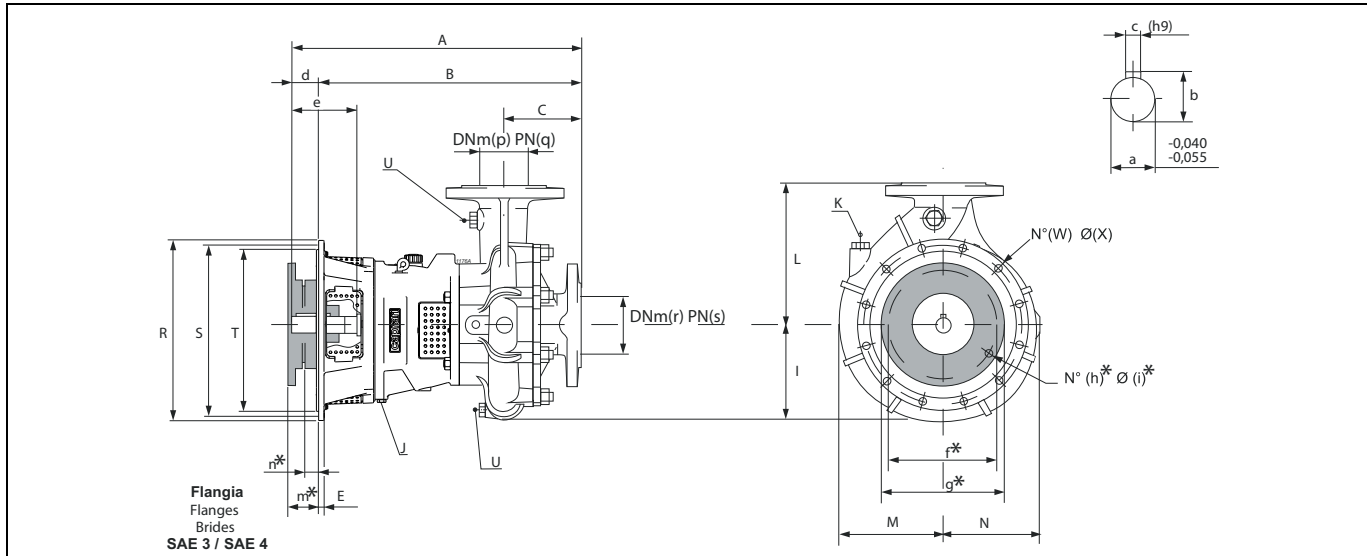

*Dimensioni variabili in funzione della grandezza giunto
*Variable dimensions according to coupling's size

Type Type Tipo	Weight Poids Peso [kg]	A	B	C	E	I	J	K	L	M	N	R	S	T	U	W	X	p	q	r	s
		[mm]																			
MEC-AG 3H3/65	108.5	528,8	508,8	119,8	12	201,5	G 3/8"	G 3/8"	275	201,5	201,5	403	381	362	G 3/8"	12	11	65	25	80	16
MEC-AG 3H4/65	105	528,8	508,8	119,8	12	201,5	G 3/8"	G 3/8"	275	201,5	201,5	403	381	362	G 3/8"	12	11	65	25	80	16
MEC-AG 3H4/80	97.5	557	537	148	12	191	G 3/8"	G 3/8"	300	204	180	403	381	361,95	G 3/8"	12	11	80	16	100	16
MEC-AG 4H4/80	115.5	562	542	153	12	224	G 3/8"	G 3/8"	325	244	222	403	381	361,95	G 3/8"	12	11	80	16	100	16
MEC-AG 2H4/100	99.5	556	536	147	12	184	G 3/8"	G 3/8"	275	203	162	403	381	361,95	G 3/8"	12	11	100	16	125	16
MEC-AG 3H4/100	107.5	556	536	147	12	204	G 3/8"	G 3/8"	300	220	188	403	381	361,95	G 3/8"	12	11	100	16	125	16
MEC-AG 4H4/100	129.5	566	546	157	12	235	G 3/8"	G 3/8"	375	247	220	403	381	361,95	G 3/8"	12	11	100	16	125	16
MEC-AG 1H4/125	113.5	573	553	164	12	205	G 3/8"	G 3/8"	300	227	180	403	381	361,95	G 3/8"	12	11	125	16	150	16
MEC-AG 2H4/125	129.5	564	544	155	12	228	G 3/8"	G 3/8"	350	247	208	403	381	361,95	G 3/8"	12	11	125	16	150	16

Shaft projection Saille d'arbre Sporgenza d'albero					
Type Type Tipo	a	b	c	d	e
	[mm]				
MEC-AG3H3/65 MEC-AG3H4/65 MEC-AG3H4/80 MEC-AG4H4/80 MEC-AG2H4/100 MEC-AG3H4/100 MEC-AG4H4/100 MEC-AG1H4/125 MEC-AG2H4/125	35	38	10	20	86

Coupling Accouplement Giunto									
Pump type Pompe type Pompa tipo	Type Type Tipo	Size Taille Grand.	Weight Poids Peso [kg]	f*	g*	h*	i*	m*	n*
				[mm]					
MEC-AG3H3/65 MEC-AG3H4/65 MEC-AG3H4/80 MEC-AG4H4/80 MEC-AG2H4/100 MEC-AG3H4/100 MEC-AG4H4/100 MEC-AG1H4/125 MEC-AG2H4/125	G220.08.35.I	8"	13	244,475	263,525	6	11,5	62	33
	G220.10.35.I	10"	14	295,275	314,325	8	11,5	54	25
	G250.11.35.I	11½"	28,8	333,375	352,425	8	11,5	40	6,5

Overall dimensions and weights
 Dimensions d'encombrement et poids
 Dimensioni di ingombro e pesi

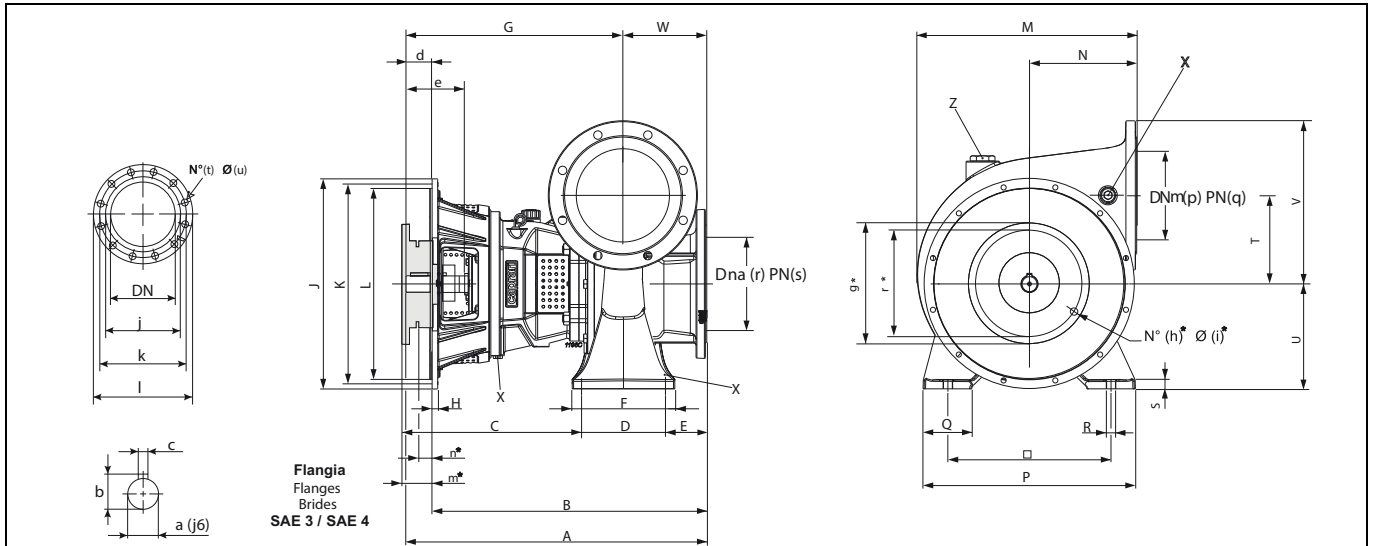

*Dimensioni variabili in funzione della grandezza giunto
 *Variable dimensions according to coupling's size

Type Type Tipo	Weight Poids Peso [kg]	A	B	C	D	E	F	G	H	J	K	L	M	N	O	P	Q	R	S	T	U	V	W	X	Z	t	u	j	k	l	p	q	r	s
		[mm]																																
BHG200H3	192	609,2	589,2	340,6	180	88,6	220	429,2	12	450,8	428,6	409,6	471	230	350	455	104	19	20	190	225	350	180	G 3/8	G 1 1/4	8	18	250	280	320	200	6	200	6
BHG200H4	188.5	609,2	589,2	340,6	180	88,6	220	429,2	12	403	381	362	471	230	350	455	104	19	20	190	225	350	180	G 3/8	G 1 1/4	8	18	250	280	320	200	6	200	6
BHG250H3	286	620	600	261	250	89	300	406	12	450,8	428,6	409,6	661	375	500	608	110	25	35	270	325	456	214	G 3/8	G 1 1/4	12	18	300	335	372	250	6	250	6
BHG250H4	282.5	620	600	261	250	89	300	406	12	403	381	362	661	375	500	608	110	25	35	270	325	456	214	G 3/8	G 1 1/4	12	18	300	335	372	250	6	250	6

Shaft projection Saillie d'arbre Sporgenza d'albero					
Type Type Tipo	a	b	c	d	e
[mm]					
BHG200	42	45	12	20	86
BHG250	42	45	12	20	86

Coupling Accouplement Giunto									
Pump type Pompe type Pompa tipo	Type Type Tipo	Size Taille Grand.	Weight Poids Peso [kg]	f*	g*	h*	i*	m*	n*
[mm]									
BHG200H3 BHG200H4 BHG250H3 BHG250H4	G220.08.35.l	8"	13	244,475	263,525	6	11,5	62	33
	G220.10.35.l	10"	14	295,275	314,325	8	11,5	54	25
	G250.11.35.l	11½"	28,8	333,375	352,425	8	11,5	40	6,5