

NCH 150-500

1450 n [min⁻¹]

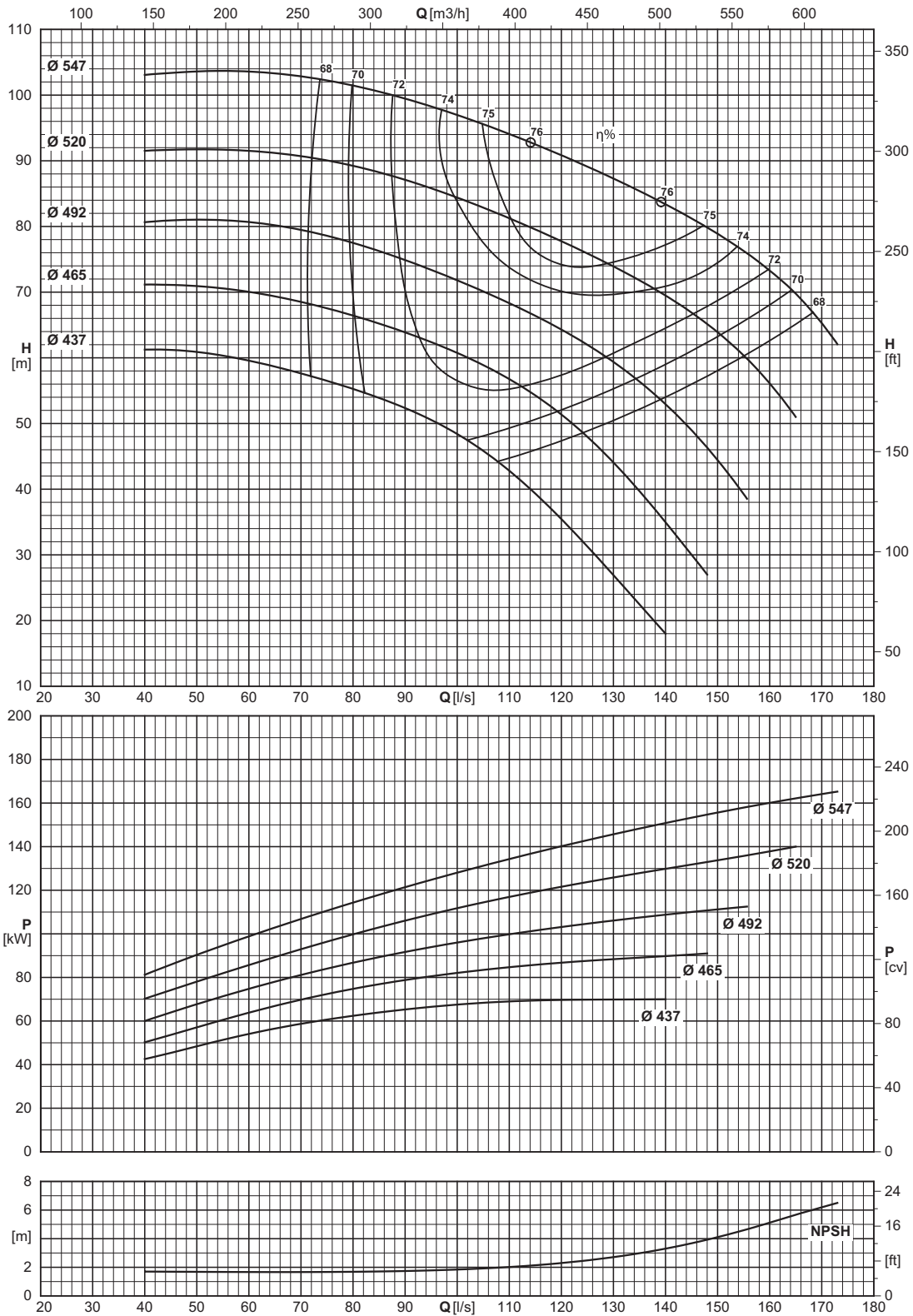

Operating data
Caracteristiques de fonctionnement
Caratteristiche di funzionamento



Type Type Tipo	Inlet maximum pressure (*) Pression maximale en aspiration (*) Pressione massima in aspirazione (*)	Dynamic momentum J Momentum dynamique J Momento dinamico J	
		With cast iron impellers Avec roues en fonte Con giranti in ghisa	With AISI 316 impellers Avec roues en AISI 316 Con giranti in AISI 316
		J = 1/4 PD ²	
	[bar]	[kgm ²]	[kgm ²]
NCH150-500	5	1,2431564	(F) 1,420750

(*) Value referred to the impeller with maximum diameter.

(*) Valeur se référant à la roue à ailettes avec le diamètre maximum. (*) Valore riferito alla girante con diametro massimo.

Overall dimensions and weights
 Dimensions d'encombrement et poids
 Dimensioni di ingombro e pesi

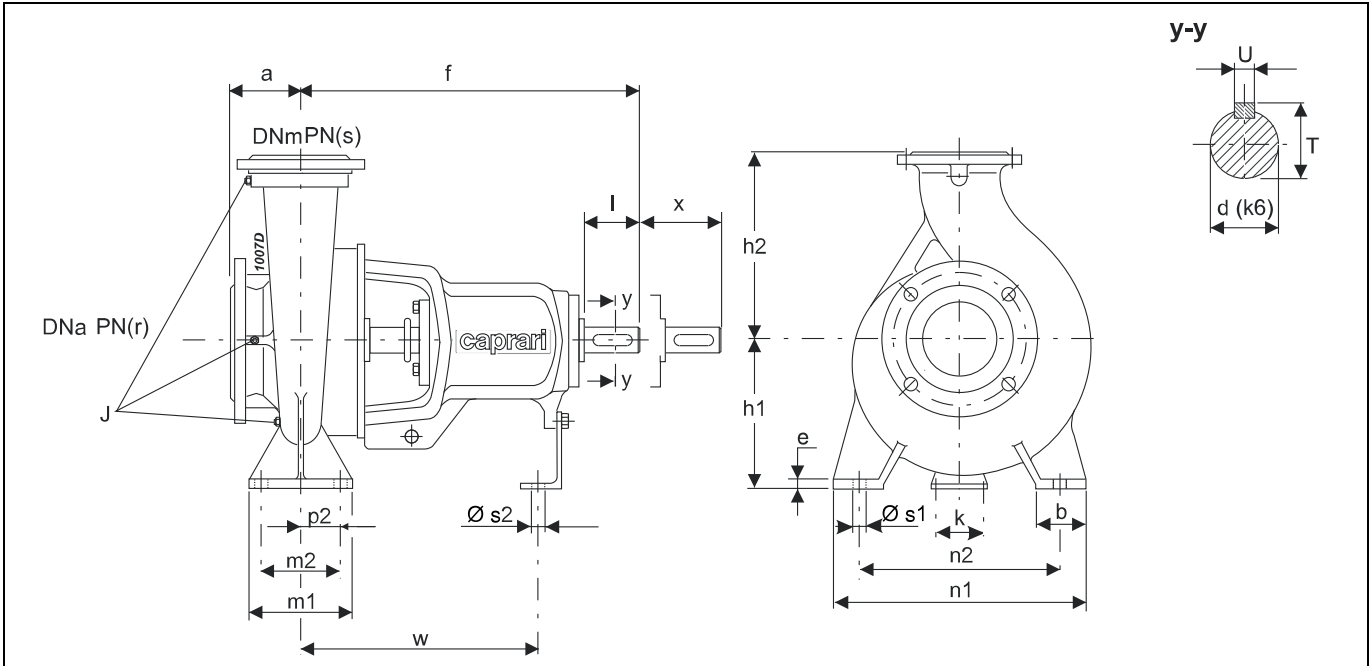

Type Type Tipo	Dimensions pump Dimensions pompe Dimensioni pompa							Duck foot pedestal dimensions Dimensiones pieds de soutien Dimensioni piedi di appoggio										Shaft projection Saillie d'arbre Sporgenza d'albero					Plugs Bouchons Tappi	Weight Poids Peso		
	DNa	DNm	r	s	a	f	h1	h2	b	e	m1	m2	p2	n1	n2	k	w	s1	s2	d	l	T	U		X	J
[mm]																										
NC100-200	125	100	16	16	125	470	200	280	80	16	160	120	-	360	280	110	340	Ø 18	Ø 14	32	80	35	10	140	G3/8×3. G1/4	85
NC100-250	125	100	16	16	140	470	225	280	80	16	160	120	-	400	315	110	340	Ø 18	Ø 14	32	80	35	10	140	G3/8×3. G3/8	106
NC100-315	125	100	16	16	140	470	250	315	80	16	160	120	-	400	315	110	340	Ø 18	Ø 14	32	80	35	10	140	G3/8×3. G3/8	134
NC100-400	125	100	16	16	140	530	280	355	100	18	200	150	-	500	400	110	370	Ø 23	Ø 14	42	110	45	12	140	G3/8×2 G1/2. G1/4	174
NCH100-315	125	100	16	16	140	530	250	315	80	19	160	120	-	400	315	110	370	Ø 18	Ø 14	42	110	45	12	140	G1/4×3	135
NC125-200	150	125	16	16	140	470	250	315	80	16	160	120	-	400	315	110	340	Ø 18	Ø 14	32	80	35	10	140	G3/8×3. G3/8	106
NC125-250	150	125	16	16	140	470	250	355	80	16	160	120	-	400	315	110	340	Ø 18	Ø 14	32	80	35	10	140	G3/8×3. G3/8	125
NC125-315	150	125	16	16	140	530	280	355	100	18	200	150	-	500	400	110	370	Ø 23	Ø 14	42	110	45	12	140	G3/8×2 G1/2. G1/4	163
NC125-400	150	125	16	16	140	530	315	400	100	18	200	150	-	500	400	110	370	Ø 23	Ø 14	42	110	45	12	140	G3/8×2 G1/2. G1/4	191
NCH125-250	150	125	16	16	140	530	250	355	80	19	160	120	-	400	315	110	370	Ø 18	Ø 14	42	110	45	12	140	G1/4×3	140
NCH125-400	150	125	16	16	140	530	315	400	100	21	200	150	-	500	400	110	370	Ø 18	Ø 14	42	110	45	12	140	G1/4×3	186
NCH125-500	150	125	16	16	160	670	355	450	100	25	200	150	-	550	450	140	500	Ø 23	Ø 18	48	110	51,5	14	180	G1/4×3	359
NC150-200	200	150	16	16	160	495	280	400	100	20	200	150	-	550	450	110	370	Ø 23	Ø 14	32	80	35	10	180	G3/8×3. G1/4	181
NC150-250	200	150	16	16	160	530	250	355	100	18	200	150	-	450	350	110	370	Ø 23	Ø 14	42	110	45	12	140	G1/4. G3/8×2 G1/2. G3/8	148
NC150-315	200	150	16	16	160	530	280	400	100	18	200	150	-	550	450	110	370	Ø 23	Ø 14	42	110	45	12	140	G1/4×3	170
NC150-400	200	150	16	16	160	530	315	450	100	18	200	150	-	550	450	110	370	Ø 23	Ø 14	42	110	45	12	140	G3/8×2 G1/2. G1/4	209
NCH150-500	200	150	16	16	160	670	400	500	100	25	200	150	60	550	450	140	480	Ø 23	Ø 18	60	140	64	18	180	G3/8×3	410
NC200-250	250	200	16	16	180	553	315	450	100	20	200	150	-	550	450	110	393	Ø 28	Ø 14	42	110	45	12	180	G3/8×2 G1/2. G3/8	220
NC200-315	250	200	16	16	180	670	315	480	120	20	220	170	-	600	480	110	504	Ø 28	Ø 14	48	110	51	14	180	G3/8×3. G3/8	251
NC200-400	250	200	16	16	180	670	335	480	120	20	220	170	-	600	480	110	504	Ø 28	Ø 14	48	110	51	14	180	G3/8×3. G3/8	295
NCH200-500	250	200	16	16	225	885	400	580	150	28	315	250	-	760	630	180	670	Ø 28	Ø 18	65	140	69	18	250	G3/8×3	577
NC250-315	300	250	16	16	220	691	355	520	150	22	250	200	-	660	510	110	525	Ø 28	Ø 14	48	110	51	14	180	G3/8×3. G3/8	311
NC250-400	300	250	16	16	220	682	400	560	150	22	250	200	-	660	510	110	516	Ø 28	Ø 14	48	110	51	14	180	G3/8×3. G3/8	390
NCH250-250	300	250	16	16	225	885	355	560	125	24	250	190	-	630	500	180	670	Ø 23	Ø 18	65	140	69	18	250	G3/8×3	434
NCH250-500	300	250	16	16	225	885	450	630	150	28	315	250	-	760	630	180	670	Ø 28	Ø 18	65	140	69	18	250	G3/8×3	670
NCHF250-500	300	250	16	16	225	885	450	630	150	28	315	250	-	760	630	180	670	Ø 28	Ø 18	65	140	69	18	250	G3/8×3	670

