

Electric pump type <i>Electropompe type</i> Elettropompa tipo	Impeller type <i>Roue type</i> Girante tipo	Capacity <i>Debit</i> Portata																		
		[l/m]	1200	2400	3600	4800	6000	7200	8400	9600	10800	12000	13500	15000	16500	18000	19500	21000	22500	24000
		[m³/h]	72	144	216	288	360	432	504	576	648	720	810	900	990	1080	1170	1260	1350	1440
		[l/s]	20	40	60	80	100	120	140	160	180	200	225	250	275	300	325	350	375	400
		Total manometric head <i>Hauteur manometrique totale</i> Prevalenza manometrica totale																		
SCC-2-300-400	A	[m]		58,5	58,3	58,1	57,8	57,5	57,1	56,7	56,2	55,6	54,7	53,6	52,3	50,7	48,8	46,5	43,7	40,5
SCC-2-300-400	B	[m]		52,8	52,6	52,4	52,2	51,9	51,6	51,1	50,5	49,8	48,7	47,3	45,6	43,6	41,4	38,8	36	
SCC-2-300-400	C	[m]	46,5	46,3	46,1	45,9	45,6	45,3	44,8	44,3	43,6	42,8	41,5	40	38,3	36,3	34,1	31,7		
SCC-2-300-400	D	[m]	39,1	39	38,8	38,5	38,2	37,8	37,4	36,8	36,2	35,4	34,3	32,8	30,9	28,6	25,7			
NPSH		[m]		3,6	3,6	3,6	3,7	3,7	3,7	3,7	3,8	3,8	3,9	4,1	4,4	4,7	5,2	5,8	6,6	7,6

Overall dimensions and weights
 Dimensions d'encombrement et poids
 Dimensioni di ingombro e pesi

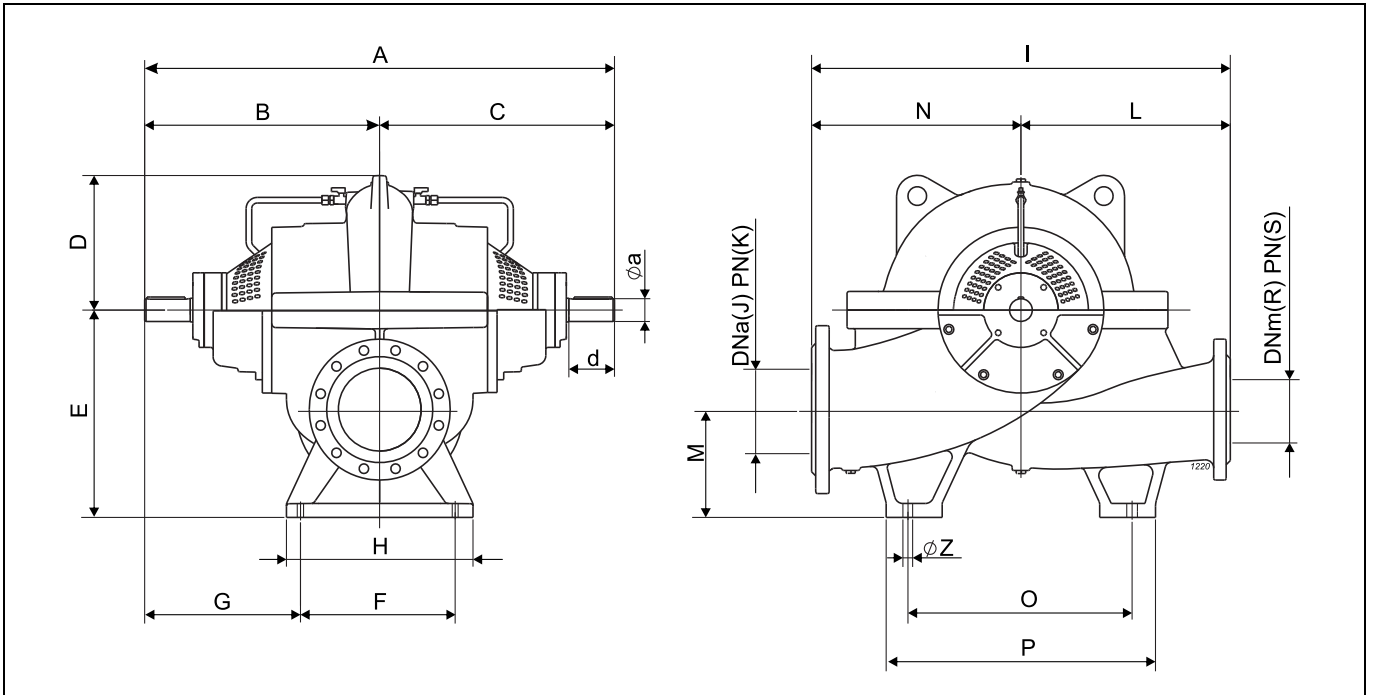

Type Type Tipo	Weight Poids Peso	A	B	C	D	E	F	G	H	I	J	K	L	M	N	O	P	R	S	Z	a	d
		[mm]																				
SCC-2-65-250	157	796	398	398	210	300	230	283	300	600	100	16	280	160	320	380	467	65	16	20	35	75
SCC-2-80-250	162	796	398	398	226	300	233	280	303	599	125	16	280	160	319	405	469	80	16	20	35	75
SCC-2-80-315	200	796	398	398	270	300	225	283,5	300	660	125	16	300	160	360	400	488	80	16	20	35	75
SCC-2-100-250	223	895	447,5	447,5	234	355	281	307	340	670	150	16	310	185	360	400	483	100	16	20	42	90
SCC-2-100-315	230	895	447,5	447,5	252	355	275	309	340	670	150	16	310	185	360	400	485	100	16	20	42	90
SCC-2-100-400	303	895	447,5	447,5	303	355	280	307,5	340	790	150	16	370	185	420	460	560	100	16	20	42	90
SCC-2-125-315	360	1052	526	526	284	400	320	366	380	790	200	16	370	200	420	460	540	125	16	22	55	110
SCC-2-125-350	402	1052	526	526	310	400	320	366	380	920	200	16	450	200	470	540	660	125	16	22	55	110
SCC-2-125-480	400	983	491,5	491,5	308	400	340	321,5	390	900	200	16	450	200	450	560	640	125	16	22	42	90
SCC-2-150-315	400	1052	526	526	319	400	320	366	380	870	200	16	400	200	470	540	643	150	16	22	55	110
SCC-2-150-460	430	1090	545	545	305	400	320	385	380	900	200	16	450	200	450	540	640	150	16	22	55	110
SCC-2-150-600	780	1284	642	642	437	560	320	482	420	1050	250	25	500	260	550	640	640	150	25	22	65	130
SCC-2-200-315	590	1284	642	642	337	500	360	462	420	950	250	16	450	260	500	540	643	200	16	22	65	130
SCC-2-200-430	630	1132	566	566	317	500	360	386	450	1000	250	16	500	260	500	540	650	200	16	24	55	110
SCC-2-200-500	690	1284	642	642	377	560	360	462	420	1050	250	16	500	260	550	620	724	200	16	22	65	130
SCC-2-250-350	680	1284	642	642	399	600	356	464	420	1100	300	16	500	300	600	620	724	250	16	30	65	130
SCC-2-250-450	780	1284	642	642	424	600	360	462	420	1100	300	16	500	300	600	620	720	250	16	23	65	130
SCC-2-250-600	1050	1440	720	720	441	600	405	517,5	485	1200	300	25	550	300	650	620	715	250	25	26	80	170
SCC-2-300-315	700	1284	642	642	400	630	348	468	420	1100	350	16	500	330,03	600	620	700	300	16	24	65	130
SCC-2-300-400	930	1328	664	664	365	630	420	454	520	1190	400	16	560	310	630	680	800	300	16	26	60	140
SCC-2-300-500	1500	1519	759,5	759,5	436	710	410	554,5	520	1450	400	16	750	360	700	700	809	300	16	26	80	170
SCC-2-300-700	1650	1731	865,5	865,5	489	710	410	660,5	520	1550	400	25	800	360	750	720	880	300	25	26,5	100	180
SCC-2-350-350	1120	1544	772	772	449	670	420	562	520	1250	400	16	550	320	700	720	804	350	16	26	75	140
SCC-2-350-400	1410	1545	772,5	772,5	502	800	500	522,5	600	1400	500	16	600	420	800	800	961	350	16	26	75	140
SCC-2-350-500	1435	1509	754,5	754,5	443	800	498	505,5	600	1400	500	16	600	400	800	740	910	350	16	26	80	170
SCC-2-350-700	2000	1731	865,5	865,5	534	850	498	616,5	600	1600	500	25	750	400	850	720	890	350	25	26	100	180

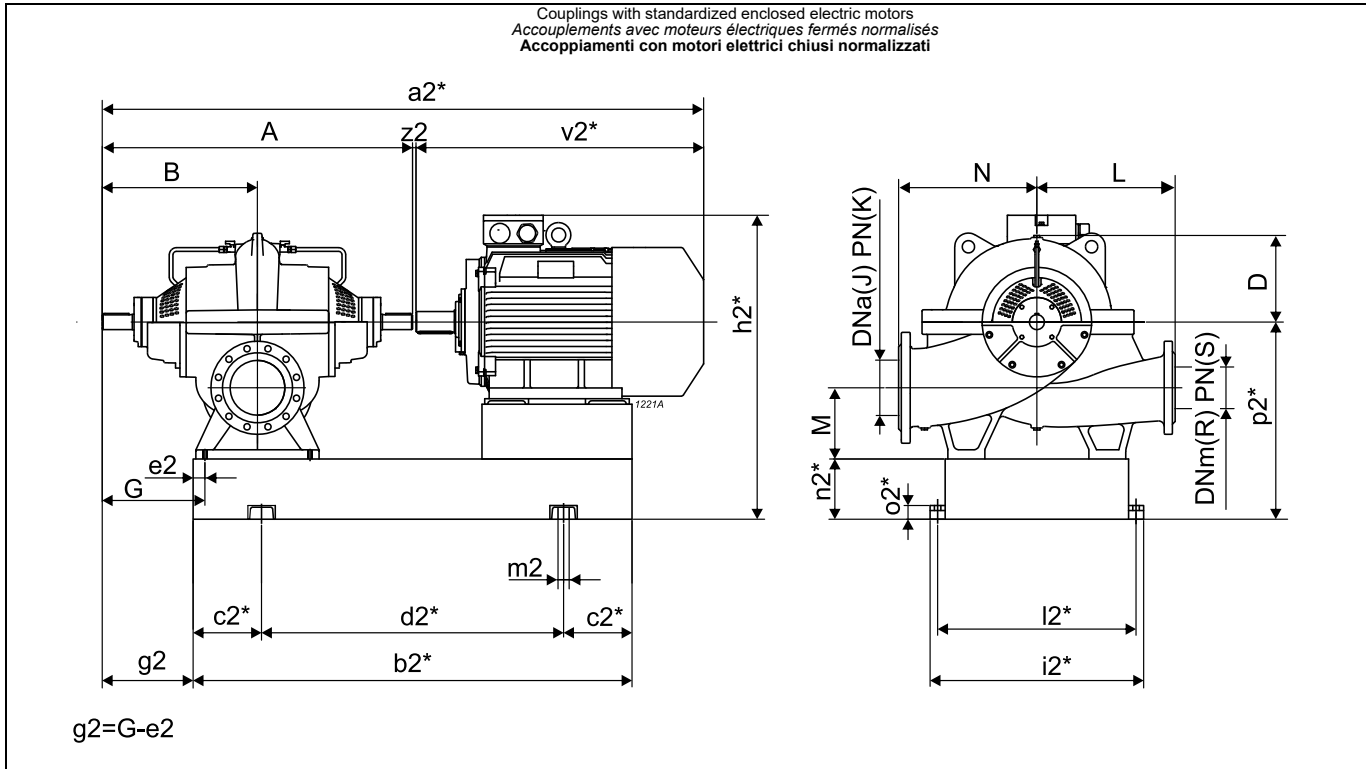

Pump Pompe Pompa	Motor Moteur Motore		Weight Poids Peso	BGAC2	A	B	D	G	J	K	L	M	N	R	S	a2*	b2*	c2*	d2*	e2	h2*	i2*	l2*	m2	n2*	o2*	p2*	v2*	z2		
	Type Type Tipo	[kW]			Size Taille Grand.	[kg]	[mm]																								
SCC-2-250-450	315	355L	2978	250-450-315/355	1284	642	424	462	300	16	500	300	600	250	16	2844	2080	350	1380	50	1421	860	810	22	220	50	820	1556	4		
SCC-2-250-450	355	355L	2993	250-450-315/355	1284	642	424	462	300	16	500	300	600	250	16	2844	2080	350	1380	50	1421	860	810	22	220	50	820	1556	4		
SCC-2-250-600	355	355L	3270	250-600-355	1440	720	441	517,5	300	25	550	300	650	250	25	3000	2191	350	1491	55	1421	860	810	22	220	50	820	1556	4		
SCC-2-300-315	37	225S	1349	300-315-37	1284	642	400	468	350	16	500	330	600	300	16	2081	1579	250	1079	50	1180	850	800	22	220	50	850	793	4		
SCC-2-300-315	45	225M	1394	300-315-45	1284	642	400	468	350	16	500	330	600	300	16	2106	1604	250	1104	50	1180	850	800	22	220	50	850	818	4		
SCC-2-300-315	55	250M	1504	300-315-55	1284	642	400	468	350	16	500	330	600	300	16	2168	1661	300	1061	50	1225	850	800	22	220	50	850	880	4		
SCC-2-300-315	75	280S	1628	300-315-75	1284	642	400	468	350	16	500	330	600	300	16	2301	1672	300	1072	50	1245	850	800	22	220	50	850	1013	4		
SCC-2-300-315	90	280M	1697	300-315-90	1284	642	400	468	350	16	500	330	600	300	16	2352	1723	300	1123	50	1245	850	800	22	220	50	850	1064	4		
SCC-2-300-400	132	315M	2364	300-400-132	1328	664	365	454	400	16	560	310	630	300	16	2653	1912	300	1312	60	1405	930	880	22	220	50	850	1321	4		
SCC-2-300-400	160	315L	2472	300-400-160	1328	664	365	454	400	16	560	310	630	300	16	2653	1963	350	1263	60	1405	930	880	22	220	50	850	1321	4		
SCC-2-300-400	200	315L	2595	300-400-200	1328	664	365	454	400	16	560	310	630	300	16	2743	2031	350	1341	60	1405	930	880	22	220	50	850	1411	4		
SCC-2-300-400	250	355M	2953	300-400-250	1328	664	365	454	400	16	560	310	630	300	16	2888	2083	350	1383	60	1451	930	880	22	220	50	850	1556	4		
SCC-2-300-500	250	355M	3560	300-500-250	1519	759,5	436	554,5	400	16	750	360	700	300	16	3079	2168	350	1468	70	1531	940	890	22	220	50	930	1556	4		
SCC-2-300-500	315	355L	3758	300-500-315/355	1519	759,5	436	554,5	400	16	750	360	700	300	16	3079	2238	350	1538	70	1531	940	890	22	220	50	930	1556	4		
SCC-2-300-500	355	355L	3773	300-500-315/355	1519	759,5	436	554,5	400	16	750	360	700	300	16	3079	2238	350	1538	70	1531	940	890	22	220	50	930	1556	4		
SCC-2-350-350	90	280M	2179	350-350-90	1544	772	449	562	400	16	550	320	700	350	16	2612	1935	300	1335	70	1285	930	880	22	220	50	890	1064	4		
SCC-2-350-350	110	315S	2348	350-350-110	1544	772	449	562	400	16	550	320	700	350	16	2759	1948	300	1348	70	1445	930	880	22	220	50	890	1211	4		
SCC-2-350-350	132	315M	2459	350-350-132	1544	772	449	562	400	16	550	320	700	350	16	2869	1999	350	1299	70	1445	930	880	22	220	50	890	1321	4		
SCC-2-350-350	160	315L	2622	350-350-160	1544	772	449	562	400	16	550	320	700	350	16	2869	2050	350	1350	70	1445	930	880	22	220	50	890	1321	4		
SCC-2-350-350	200	315L	2687	350-350-200	1544	772	449	562	400	16	550	320	700	350	16	2959	2138	350	1438	70	1445	930	880	22	220	50	890	1411	4		
SCC-2-350-400	160	315L	3187	350-400-160	1545	772,5	502	522,5	500	16	600	420	800	350	16	2870	2080	350	1380	70	1575	1110	1060	22	220	50	1020	1321	4		
SCC-2-350-400	200	315L	3329	350-400-200	1545	772,5	502	522,5	500	16	600	420	800	350	16	2960	2170	350	1470	70	1575	1110	1060	22	220	50	1020	1411	4		
SCC-2-350-400	250	355M	3654	350-400-250	1545	772,5	502	522,5	500	16	600	420	800	350	16	3105	2200	350	1500	70	1621	1110	1060	22	220	50	1020	1556	4		
SCC-2-350-400	315	355L	3850	350-400-315/355	1545	772,5	502	522,5	500	16	600	420	800	350	16	3105	2270	350	1570	70	1621	1110	1060	22	220	50	1020	1556	4		
SCC-2-350-400	355	355L	3865	350-400-315/355	1545	772,5	502	522,5	500	16	600	420	800	350	16	3105	2270	350	1570	70	1621	1110	1060	22	220	50	1020	1556	4		
SCC-2-350-500	355	355L	3867	350-500-355	1509	754,5	443	505,5	500	16	600	400	800	350	16	3069	2253	350	1553	70	1621	1050	1000	22	220	50	1020	1556	4		

BGAC2 = Base and coupling

* = Indicatives values according to the type of motor installed.

o Motor in IE4 efficiency class according to EU REGULATION 2019/1781. Available in other efficiency classes for non-EU markets.

BGAC2 = Socle et accouplement

* = Valeurs indicatives en fonction de la marque du moteur utilisé.

o Moteur en classe de rendement IE4 conformément au RÈGLEMENT UE2019/1781. Disponibilit  en diff rentes classes de rendement pour les march s hors UE.

BGAC2 = Base e giunto

* = Valori indicativi in funzione della marca di motore utilizzato.

o Motore in classe di efficienza IE4 in conformit  al REGOLAMENTO UE2019/1781. Disponibili in altre classi di efficienza per mercati extra UE.