

Utilization field Champ d'utilisation Campo di utilizzo ≥ 67% η; ≥ 85 l/s		
Stage number: compatibly with the maximum pressure. Nombre d'étages: compatible avec la pression maximum. Numero stadi: compatibilmente con la pressione massima di esercizio.		
Type Type Tipo	MIN.	MAX.
PMXT	2	6
PMXST	2	6
NB. For two-stage pumps only, reduce efficiency by one point. Diminuer le rendement d'un point seulement pour les pompes à deux étages. Solamente per le pompe a due stadi, ridurre di un punto il rendimento.		

Wet moment of inertia J Moment d'inertie J mouillé Momento d'inertzia J bagnato $J = \frac{1}{4}PD^2 - [kg\ m^2]$		
Impeller type Roue type Girante tipo	PMX(S)T150/1	For each additional stage Pour chaque étage en plus Per ogni stadio in più
Stainless steel Acier inox Acciaio inox	0,1738	0,1443

Maximum permissible power Puissances maximums admissibles Massime potenze ammissibili	
Type Type Tipo	N/n MAX.
PMXT	0,31
PMXST	0,31
For seal limits and calculation formulas of the maximum permissible powers, see technical data section. Consulter la section Données techniques pour connaître les limites des joints et les formules pour le calcul des puissances maximales admises. Per i limiti tenute e le formule di calcolo delle massime potenze ammissibili, vedere sezione dati tecnici.	

PERFORMANCES EACH INTERMEDIATE STAGE  
CARACTERISTIQUES POUR CHAQUE ETAGE  
PRESTAZIONI PER STADIO

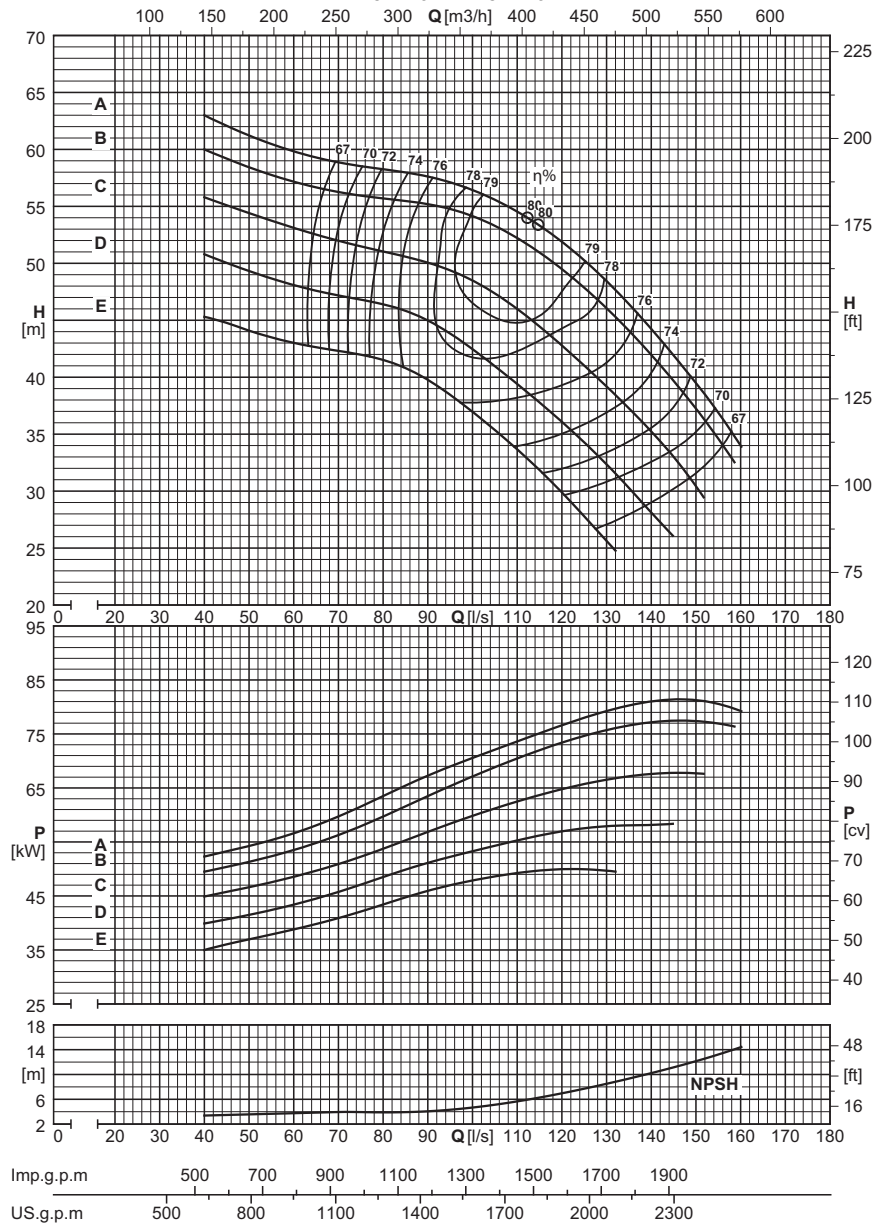

Dna x Dnm	Impeller type Roue type Girante tipo	Capacity - Debit - Portata																					
		[l/s]	0	84	88	92	96	100	104	108	112	116	120	124	128	132	136	140	144	148	152	156	160
		[m³/h]	0	302,4	316,8	331,2	345,6	360	374,4	388,8	403,2	417,6	432	446,4	460,8	475,2	489,6	504	518,4	532,8	547,2	561,6	576
		[l/min]	0	5040	5280	5520	5760	6000	6240	6480	6720	6960	7200	7440	7680	7920	8160	8400	8640	8880	9120	9360	9600

		PMX(S)T150/1																					
200x150	E	[m]	50	41	40,5	39,5	38,5	37	35,5	34,5	33	31,5	29,5	28,5	26,5	25							
200x150	E	[kW]		44,5	45,5	46,5	46,5	48,5	49	49	49	49	50	50,5	50	49,5							
200x150	D	[m]	56	46,5	46	44	43,5	42,5	41,5	40	39	37,5	36	34,5	33	31	30,5	28,5					
200x150	D	[kW]		49,5	50	52,5	52,5	53	53,5	55,5	55,5	56,5	58	58	57,5	57,5	60	58,5					
200x150	C	[m]	62	49	50	50	50	48	47,5	47	45	44	43	41,5	40	38	37	35	33,5	32	29,5		
200x150	C	[kW]		56,5	56,5	57	58	60	60,5	61	63,5	64	64,5	66	66	66,5	69	67,5	67	69	67,5		
200x150	B	[m]	67	55	56	54	54	55	52	52	52	50	49,5	49	47	45	44	42	39,5	38,5	36	33	32,5
200x150	B	[kW]		61,5	62	65	65,5	66,5	70	69,5	70	72,5	73,5	75	75	75	77	77	76	78	77	75	77
200x150	A	[m]	69	58	59	56	57	55	55	55	53	53	52	50	49	47,5	46	44	43	40,5	39	37,5	34
200x150	A	[kW]		65,5	65,5	68,5	69	72	72	72,5	75	75	75	78	78	78	80	80	82	81	79	81	79

		NPSH																					
		[m]		3,9	4	4,2	4,4	4,7	5,1	5,4	5,9	6,4	7,1	7,4	8,2	8,8	9,4	10,2	11,1	11,7	12,5	13,1	14,4

Overall dimensions and weights  
 Dimensions d'encombrement et poids  
 Dimensioni di ingombro e pesi

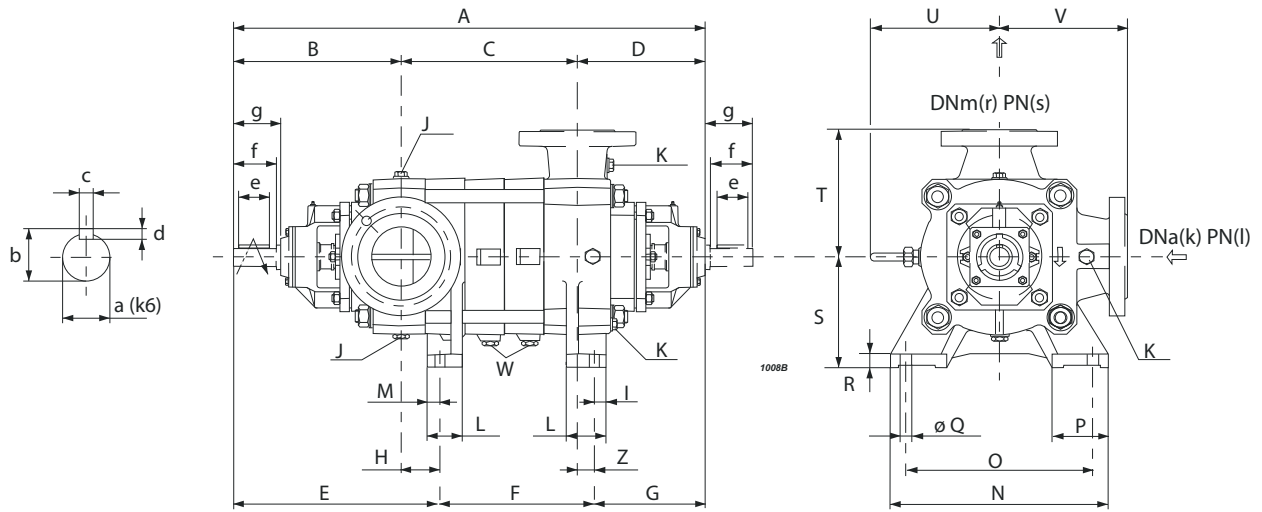

Series Série Serie	Type Type Tipo	A	B	C	D	E	F	G	H	S	T	U	V	Z	Weight Poids Peso
		[mm]													[kg]
PMX(S)T	150/2	1190	479	360	351	619	270	301	140	315	370	358	370	50	711
PMX(S)T	150/3	1315	479	485	351	619	395	301	140	315	370	358	370	50	791
PMX(S)T	150/4	1440	479	610	351	619	520	301	140	315	370	358	370	50	872
PMX(S)T	150/5	1565	479	735	351	619	645	301	140	315	370	358	370	50	953
PMX(S)T	150/6	1690	479	860	351	619	770	301	140	315	370	358	370	50	1033
PMX(S)T	150/7	1815	479	985	351	619	895	301	140	315	370	358	370	50	1114
PMX(S)T	150/8	1940	479	1110	351	619	1020	301	140	315	370	358	370	50	1195

Foot dimensions Dimensions des pieds Dimensioni dei piedi							
I	L	M	N	O	P	Q	R
[mm]							
43	125	45	680	590	170	24	40

Shaft projection Salle d'arbre Sporgenza d'albero						
a	b	c	d	e	f	g
[mm]						
55	59	16	10	120	130	145

Type Type Tipo	Flanges Brides Flange			
	(k) DNa	(l) PN	(r) DNm	(s) PN
	[mm]	[bar]	[mm]	[bar]
PMXT	200	25	150	40
PMXST	200	25	150	63

Plugs Bouchons Tappi		
J	K	W
G3/4	G1/2	G1/4

COUPLINGS WITH STANDARDIZED ENCLOSED ELECTRIC MOTORS  
 ACCOUPLEMENTS AVEC MOTEURS ÉLECTRIQUES FERMÉS NORMALISÉS  
 ACCOPIAMENTI CON MOTORI ELETTRICI CHIUSI NORMALIZZATI

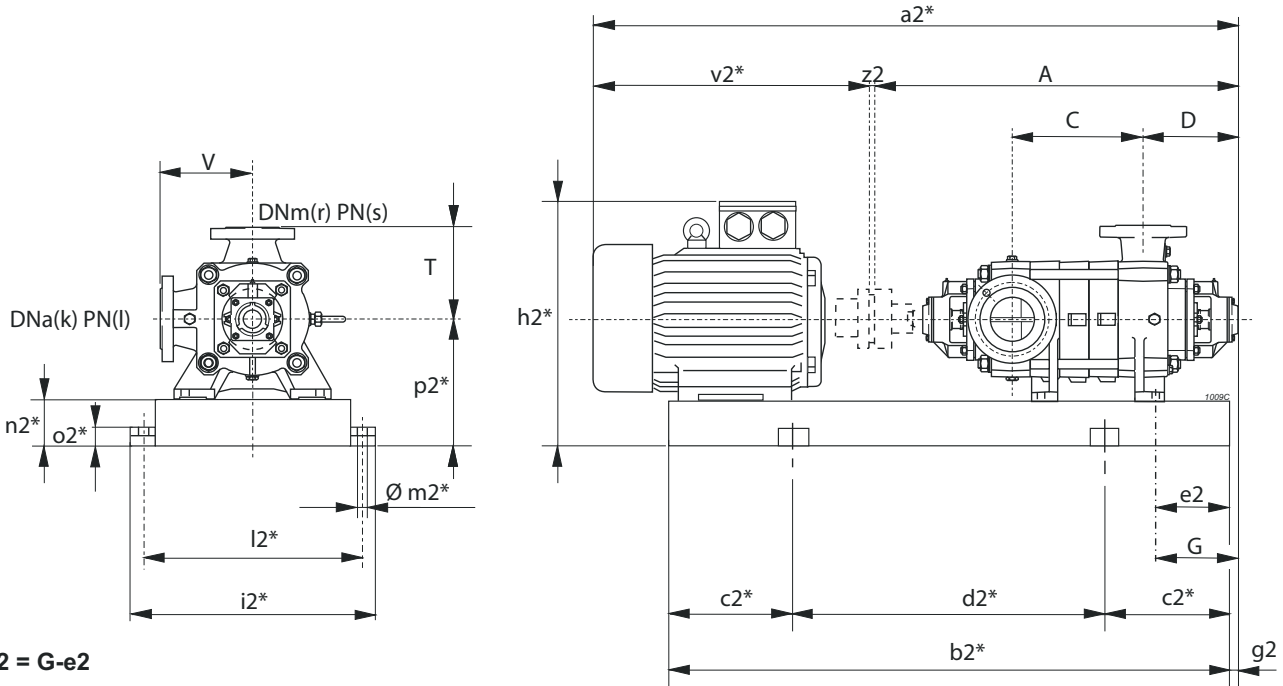

$g2 = G - e2$

\* Valori indicativi in funzione della marca di motore utilizzato  
 Indicatives values according to the type of motor installed

Pump Pompe Pompa	Motor Moteur Motore	BGAM	A	C	D	G	T	V	a2*	b2*	c2*	d2*	e2	h2*	i2*	k	l	l2*	m2*	n2*	o2*	p2*	r	s	v2*	z2	Weight Poids Peso		
Series Série Serie	Type Type Tipo	[kW]	Size Taille Grand.	Type Type Tipo	[mm]																				[kg]				
PMX(S)T	150/2	45	225M	705/HR	1190	360	351	301	370	370	2074	1671	300	1071	60	850	810	200	25	760	22	160	50	475	150	(2)	880	4	1266
PMX(S)T	/2	55	250M	706/IR	1190	360	351	301	370	370	2207	1718	300	1118	60	870	810	200	25	760	22	160	50	475	150	(2)	1013	4	1411
PMX(S)T	/2	75	280S	707/IR	1190	360	351	301	370	370	2332	1843	300	1243	60	870	810	200	25	760	22	160	50	475	150	(2)	1013	4	1490
PMX(S)T	150/3	75	280S	708/IR	1315	485	351	301	370	370	2383	1894	300	1294	60	870	810	200	25	760	22	160	50	475	150	(2)	1064	4	1559
PMX(S)T	/3	90	280M	709/LR	1315	485	351	301	370	370	2530	1970	350	1270	60	1030	810	200	25	760	22	160	50	475	150	(2)	1211	4	1849
PMX(S)T	/3	110	315S	710/LS	1315	485	351	301	370	370	2530	1970	350	1270	60	1030	810	200	25	760	22	160	50	475	150	(2)	1211	4	1849
PMX(S)T	150/4	90	280M	711/LR	1440	610	351	301	370	370	2508	2019	350	1319	60	870	810	200	25	760	22	160	50	475	150	(2)	1064	4	1638
PMX(S)T	/4	110	315S	712/LS	1440	610	351	301	370	370	2655	2095	350	1395	60	1030	810	200	25	760	22	160	50	475	150	(2)	1211	4	1928
PMX(S)T	/4	132	315M	713/MS	1440	610	351	301	370	370	2765	2205	350	1505	60	1030	810	200	25	760	22	160	50	475	150	(2)	1321	4	2056
PMX(S)T	/4	160	315L	713/MS	1440	610	351	301	370	370	2765	2205	350	1505	60	1030	810	200	25	760	22	160	50	475	150	(2)	1321	4	2151
PMX(S)T	150/5	110	315S	714/LS	1565	735	351	301	370	370	2780	2220	350	1520	60	1030	810	200	25	760	22	160	50	475	150	(2)	1211	4	2007
PMX(S)T	/5	132	315M	715/MS	1565	735	351	301	370	370	2890	2330	400	1530	60	1030	810	200	25	760	22	160	50	475	150	(2)	1321	4	2135
PMX(S)T	/5	160	315L	715/MS	1565	735	351	301	370	370	2890	2330	400	1530	60	1030	810	200	25	760	22	160	50	475	150	(2)	1321	4	2230
PMX(S)T	/5	200	315L	716/IE4/NS	1565	735	351	301	370	370	2980	2420	400	1620	198	1030	810	200	25	760	22	160	50	475	150	(2)	1411	4	2375
PMX(S)T	150/6	132	315M	717/MS	1690	860	351	301	370	370	3015	2455	400	1655	60	1030	810	200	25	760	22	160	50	475	150	(2)	1321	4	2213
PMX(S)T	/6	160	315L	717/MS	1690	860	351	301	370	370	3015	2455	400	1655	60	1030	810	200	25	760	22	160	50	475	150	(2)	1321	4	2308
PMX(S)T	/6	200	315L	718/IE4/NS	1690	860	351	301	370	370	3105	2545	400	1745	198	1030	810	200	25	760	22	160	50	475	150	(2)	1411	4	2460
PMX(S)T	/6	250	355M	719/NS	1690	860	351	301	370	370	3250	2589	450	1689	100	1136	880	200	25	830	22	180	50	535	150	(2)	1556	4	2831
PMX(S)T	150/7	132	315M	720/MS	1815	985	351	301	370	370	3140	2580	450	1680	60	1030	810	200	25	760	22	160	50	475	150	(2)	1321	4	2292
PMX(S)T	/7	160	315L	720/MS	1815	985	351	301	370	370	3140	2580	450	1680	60	1030	810	200	25	760	22	160	50	475	150	(2)	1321	4	2387
PMX(S)T	/7	200	315L	721/IE4/NS	1815	985	351	301	370	370	3230	2670	450	1770	198	1030	810	200	25	760	22	160	50	475	150	(2)	1411	4	2538
PMX(S)T	/7	250	355M	722/NS	1815	985	351	301	370	370	3375	2714	450	1814	100	1136	880	200	25	830	22	180	50	535	150	(2)	1556	4	2911
PMX(S)T	150/8	200	315L	723/IE4/NS	1940	1110	351	301	370	370	3355	2795	450	1895	198	1030	810	200	25	760	22	160	50	475	150	(2)	1411	4	2617
PMX(S)T	/8	250	355M	724/NS	1940	1110	351	301	370	370	3500	2839	450	1939	100	1136	880	200	25	830	22	180	50	535	150	(2)	1556	4	2990
PMX(S)T	/8	280	355L	724/PS	1940	1110	351	301	370	370	3500	2909	500	1909	100	1136	880	200	25	830	22	180	50	535	150	(2)	1556	4	3189
PMX(S)T	/8	315	355L	724/PS	1940	1110	351	301	370	370	3500	2909	500	1909	100	1136	880	200	25	830	22	180	50	535	150	(2)	1556	4	3189

BGAM = Base and coupling

\* = Indicatives values according to the type of motor installed.

○ Motor in IE4 efficiency class according to EU REGULATION 2019/1781. Available in other efficiency classes for non-EU markets.

(2) PMXT=40 bar PMXST=63 bar

BGAM = Socle et accouplement

\* = Valeurs indicatives en fonction de la marque du moteur utilisé.

○ Moteur en classe de rendement IE4 conformément au RÈGLEMENT UE2019/1781. Disponibilité en différentes classes de rendement pour les marchés hors UE.

(2) PMXT=40 bar PMXST=63 bar

BGAM = Base giunto e coprigiunto

\* = Valori indicativi in funzione della marca di motore utilizzato.

○ Motore in classe di efficienza IE4 in conformità al REGOLAMENTO UE2019/1781. Disponibili in altre classi di efficienza per mercati extra UE.

(2) PMXT=40 bar PMXST=63 bar

Flanges (UNI EN 1092-2)  
 Brides (UNI EN 1092-2)  
 Flange (UNI EN 1092-2)

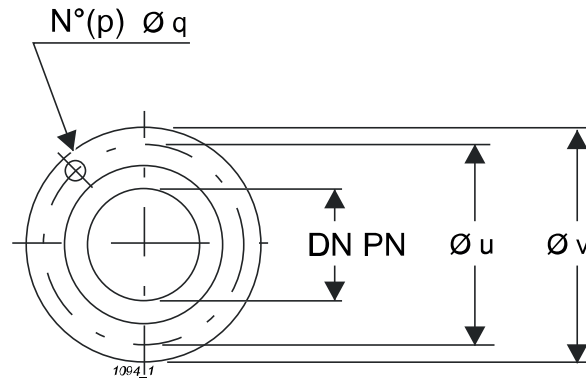

Port $\varnothing$ $\varnothing$ Orifice $\varnothing$ Bocca		Holes Trous Fori		$\varnothing u$	$\varnothing v$
DN [mm]	PN [bar]	p No	q $\varnothing$ [mm]	[mm]	
50	40	4	18	125	180
50	63	4	22	135	180
65	25	8	18	145	185
65	40	8	18	145	205
65	63	8	22	160	205
65	100	8	26	170	220
80	25	8	18	160	200
80	40	8	18	160	215
80	63	8	22	170	215
80	100	8	25	180	230
100	25	8	22	190	235
100	40	8	22	190	235
100	63	8	25	200	250
100	100	8	30	210	265
125	25	8	25	220	270
125	40	8	25	220	270
125	63	8	30	240	295
125	100	8	35	250	315
150	25	8	25	250	300
150	40	8	25	250	300
150	63	8	33	280	345
200	25	12	25	310	360