

Operating data
 Caracteristiques de fonctionnement
 Caratteristiche di funzionamento

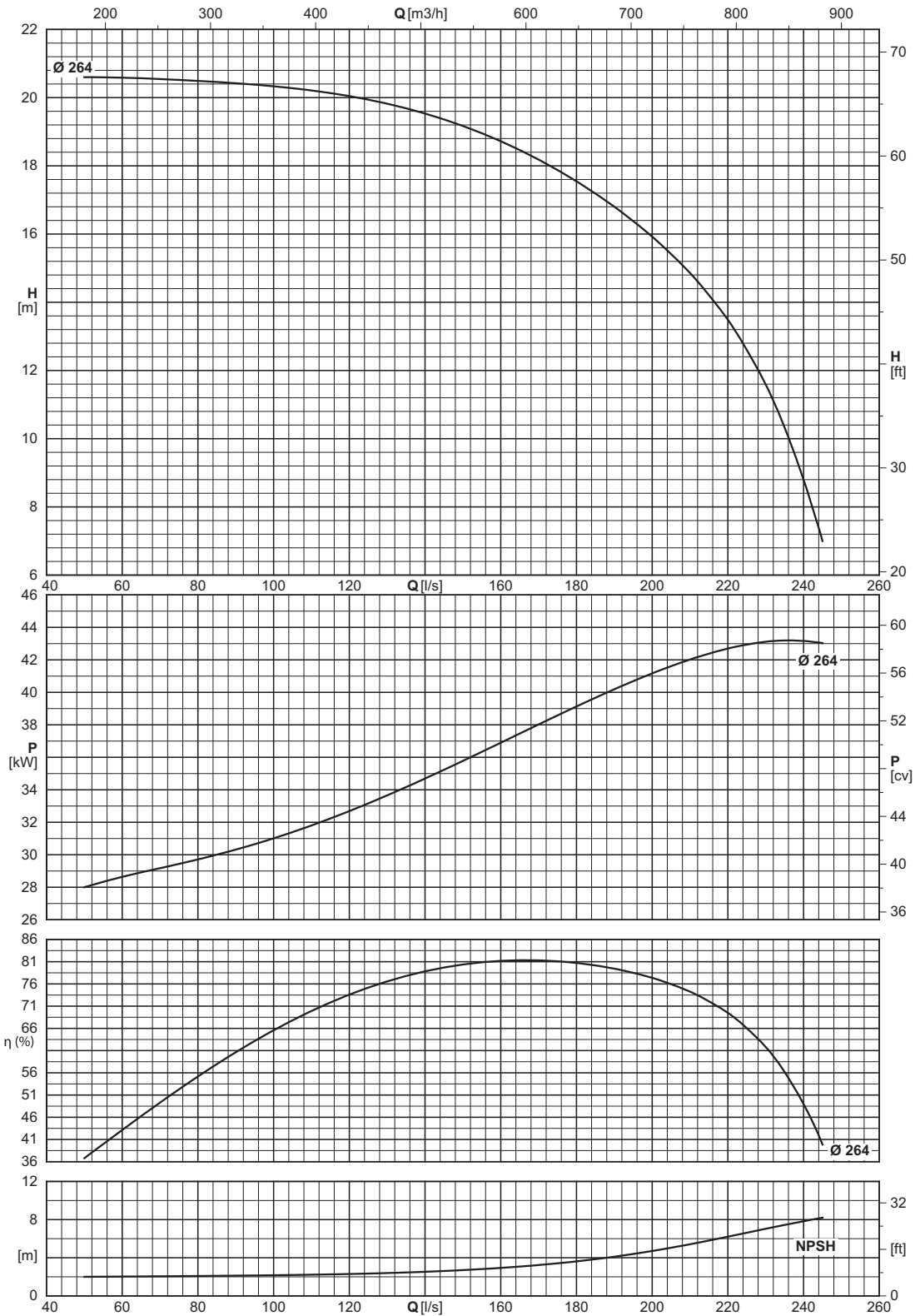

Type Type Tipo	Inlet maximum pressure (*) Pression maximale en aspiration (*) Pressione massima in aspirazione (*)	Dinamic momentum J Momentum dynamique J Momento dinamico J	
		With cast iron impellers Avec roues en fonte Con giranti in ghisa	With AISI 316 impellers Avec roues en AISI 316 Con giranti in AISI 316
		J=1/4PD ²	
		[bar]	[kgm ²]
NC200-250	6	0,113824	(F) 0,1300846

Construction reference standard EN733 (DIN24255)
 (*) Value referred to the impeller with maximum diameter.

Norme de référence construction EN733 (DIN24255)
 (*) Valeur se référant à la roue à ailettes avec le diamètre maximum.

Norma di riferimento costruttivo EN733 (DIN24255)
 (*) Valore riferito alla girante con diametro massimo.

Overall dimensions and weights
 Dimensions d'encombement et poids
 Dimensioni di ingombro e pesi

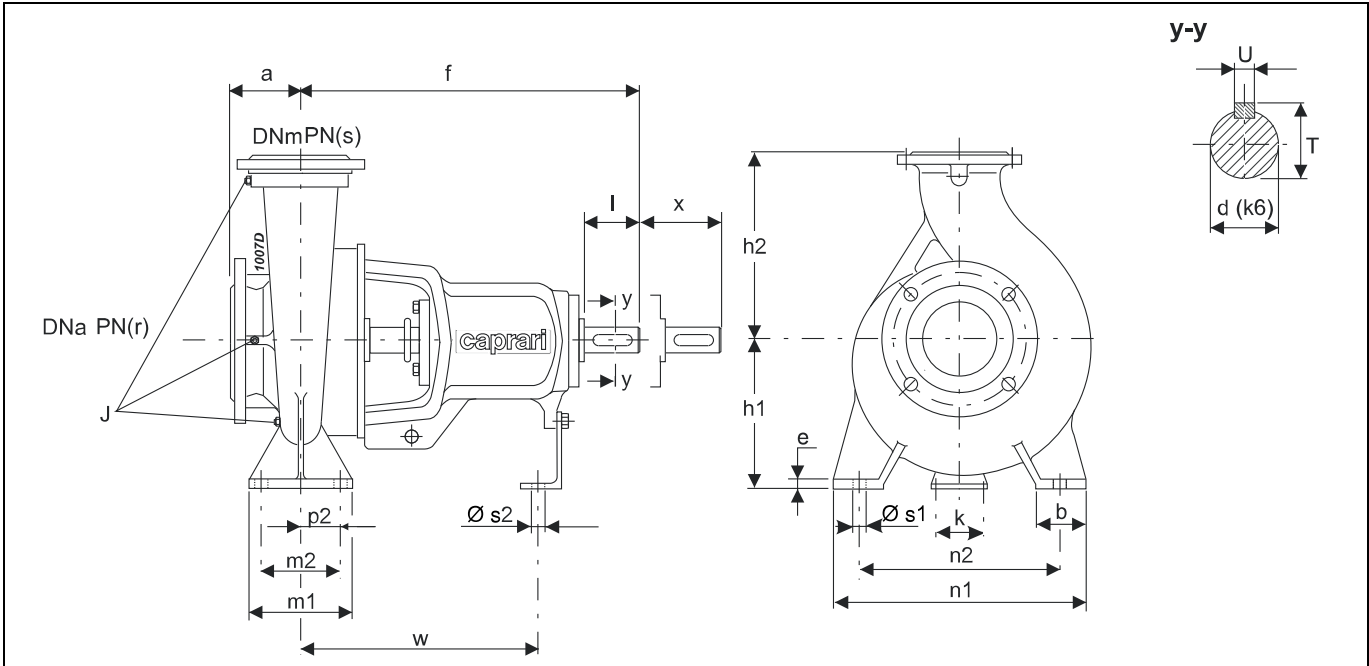

Type Type Tipo	Dimensions pump Dimensions pompe Dimensioni pompa							Duck foot pedestal dimensions Dimensiones pieds de soutien Dimensioni piedi di appoggio										Shaft projection Saillie d'arbre Sporgenza d'albero					Plugs Bouchons Tappi	Weight Poids Peso		
	DNa	DNm	r	s	a	f	h1	h2	b	e	m1	m2	p2	n1	n2	k	w	s1	s2	d	l	T	U		X	J
[mm]																										
NC100-200	125	100	16	16	125	470	200	280	80	16	160	120	-	360	280	110	340	ø 18	ø 14	32	80	35	10	140	G3/8×3. G1/4	85
NC100-250	125	100	16	16	140	470	225	280	80	16	160	120	-	400	315	110	340	ø 18	ø 14	32	80	35	10	140	G3/8×3. G3/8	106
NC100-315	125	100	16	16	140	470	250	315	80	16	160	120	-	400	315	110	340	ø 18	ø 14	32	80	35	10	140	G3/8×3. G3/8	134
NC100-400	125	100	16	16	140	530	280	355	100	18	200	150	-	500	400	110	370	ø 23	ø 14	42	110	45	12	140	G3/8×2 G1/2. G1/4	174
NCH100-315	125	100	16	16	140	530	250	315	80	19	160	120	-	400	315	110	370	ø 18	ø 14	42	110	45	12	140	G1/4×3	135
NC125-200	150	125	16	16	140	470	250	315	80	16	160	120	-	400	315	110	340	ø 18	ø 14	32	80	35	10	140	G3/8×3. G3/8	106
NC125-250	150	125	16	16	140	470	250	355	80	16	160	120	-	400	315	110	340	ø 18	ø 14	32	80	35	10	140	G3/8×3. G3/8	125
NC125-315	150	125	16	16	140	530	280	355	100	18	200	150	-	500	400	110	370	ø 23	ø 14	42	110	45	12	140	G3/8×2 G1/2. G1/4	163
NC125-400	150	125	16	16	140	530	315	400	100	18	200	150	-	500	400	110	370	ø 23	ø 14	42	110	45	12	140	G3/8×2 G1/2. G1/4	191
NCH125-250	150	125	16	16	140	530	250	355	80	19	160	120	-	400	315	110	370	ø 18	ø 14	42	110	45	12	140	G1/4×3	140
NCH125-400	150	125	16	16	140	530	315	400	100	21	200	150	-	500	400	110	370	ø 18	ø 14	42	110	45	12	140	G1/4×3	186
NCH125-500	150	125	16	16	160	670	355	450	100	25	200	150	-	550	450	140	500	ø 23	ø 18	48	110	51,5	14	180	G1/4×3	359
NC150-200	200	150	16	16	160	495	280	400	100	20	200	150	-	550	450	110	370	ø 23	ø 14	32	80	35	10	180	G3/8×3. G1/4	181
NC150-250	200	150	16	16	160	530	250	355	100	18	200	150	-	450	350	110	370	ø 23	ø 14	42	110	45	12	140	G1/4. G3/8×2 G1/2. G3/8	148
NC150-315	200	150	16	16	160	530	280	400	100	18	200	150	-	550	450	110	370	ø 23	ø 14	42	110	45	12	140	G1/4×3	170
NC150-400	200	150	16	16	160	530	315	450	100	18	200	150	-	550	450	110	370	ø 23	ø 14	42	110	45	12	140	G3/8×2 G1/2. G1/4	209
NCH150-500	200	150	16	16	160	670	400	500	100	25	200	150	60	550	450	140	480	ø 23	ø 18	60	140	64	18	180	G3/8×3	410
NC200-250	250	200	16	16	180	553	315	450	100	20	200	150	-	550	450	110	393	ø 28	ø 14	42	110	45	12	180	G3/8×2 G1/2. G3/8	220
NC200-315	250	200	16	16	180	670	315	480	120	20	220	170	-	600	480	110	504	ø 28	ø 14	48	110	51	14	180	G3/8×3. G3/8	251
NC200-400	250	200	16	16	180	670	335	480	120	20	220	170	-	600	480	110	504	ø 28	ø 14	48	110	51	14	180	G3/8×3. G3/8	295
NCH200-500	250	200	16	16	225	885	400	580	150	28	315	250	-	760	630	180	670	ø 28	ø 18	65	140	69	18	250	G3/8×3	577
NC250-315	300	250	16	16	220	691	355	520	150	22	250	200	-	660	510	110	525	ø 28	ø 14	48	110	51	14	180	G3/8×3. G3/8	311
NC250-400	300	250	16	16	220	682	400	560	150	22	250	200	-	660	510	110	516	ø 28	ø 14	48	110	51	14	180	G3/8×3. G3/8	390
NCH250-250	300	250	16	16	225	885	355	560	125	24	250	190	-	630	500	180	670	ø 23	ø 18	65	140	69	18	250	G3/8×3	434
NCH250-500	300	250	16	16	225	885	450	630	150	28	315	250	-	760	630	180	670	ø 28	ø 18	65	140	69	18	250	G3/8×3	670
NCHF250-500	300	250	16	16	225	885	450	630	150	28	315	250	-	760	630	180	670	ø 28	ø 18	65	140	69	18	250	G3/8×3	670

Selection - dimensions and weights for base mounted electric pumps
 Sélection - dimensions et poids des électropompes sur socle
 Selezione - dimensioni e pesi elettropompe su base

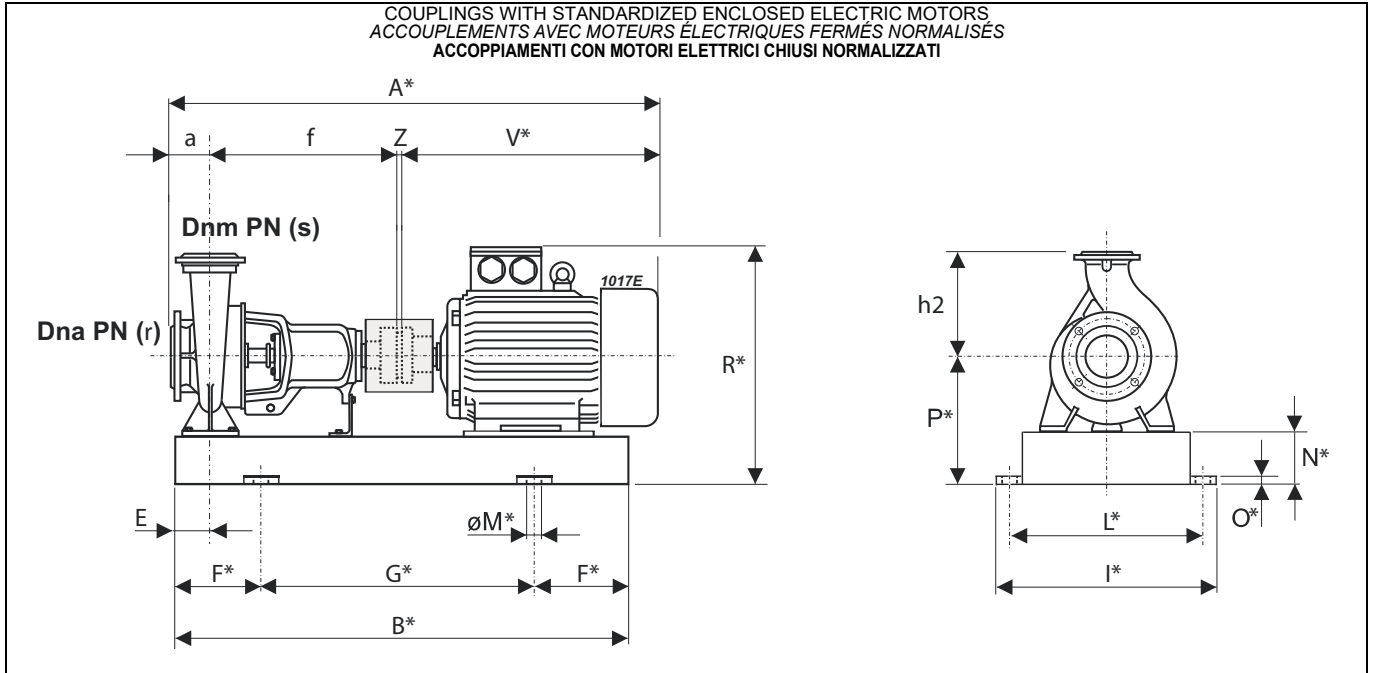

Pump Pompe Pompa			Motor Moteur Motore		BGAN	A *	B *	E	F *	G *	I *	L *	M *	N *	O *	P *	R *	V *	Z	a	f	h2	r	s	Weight Poids Peso			
Type Type Tipo	DNa [mm]	DNm [mm]	Size Taille Grand.	Type Type Tipo	[mm]																							[kg]
NC200-250	250	200	30	200L	1108/GY	1495	1305	110	200	905	680	630	∅ 22	160	50	475	775	758	4	180	553	450	16	16	621			
NC200-250	250	200	37	225S	1109/GY	1530	1308	110	200	908	680	630	∅ 22	160	50	475	805	793	4	180	553	450	16	16	694			
NC200-250	250	200	45	225M	1141/HY	1555	1333	110	200	933	680	630	∅ 22	160	50	475	805	818	4	180	553	450	16	16	703			
NC200-250	250	200	55	250M	1110/HY	1617	1385	110	250	885	680	630	∅ 22	160	50	475	850	880	4	180	553	450	16	16	819			
NC200-315	250	200	30	200L	1111/GY2	1612	1432	120	250	932	730	680	∅ 22	160	50	475	775	758	4	180	670	480	16	16	664			
NC200-315	250	200	37	225S	1112/GY2	1647	1435	120	250	935	730	680	∅ 22	160	50	475	805	793	4	180	670	480	16	16	740			
NC200-315	250	200	45	225M	1113/HY2	1672	1460	120	250	960	730	680	∅ 22	160	50	475	805	818	4	180	670	480	16	16	776			
NC200-315	250	200	55	250M	1114/HY2	1734	1512	120	250	1012	730	680	∅ 22	160	50	475	850	880	4	180	670	480	16	16	861			
NC200-315	250	200	75	280S	1115/IY2	1867	1559	120	250	1059	730	680	∅ 22	160	50	475	870	1013	4	180	670	480	16	16	926			
NC200-400	250	200	75	280S	1116/IY2	1867	1584	145	250	1084	730	680	∅ 22	160	50	495	890	1013	4	180	670	480	16	16	963			
NC200-400	250	200	90	280M	1117/IY2	1918	1635	145	250	1135	730	680	∅ 22	160	50	495	890	1064	4	180	670	480	16	16	1166			
NC200-400	250	200	110	315S	1118/LY2	2065	1711	145	300	1111	780	730	∅ 22	160	50	495	1050	1211	4	180	670	480	16	16	1250			
NC200-400	250	200	132	315M	1120/LY2	2175	1770	145	300	1170	780	730	∅ 22	160	50	495	1050	1321	4	180	670	480	16	16	1395			
NCH200-500	250	200	90	280M	2027/IY4	2178	1885	170	300	1285	890	840	∅ 22	200	50	600	995	1064	4	225	885	580	16	16	1489			
NCH200-500	250	200	110	315S	2028/LY4	2325	1961	170	350	1261	890	840	∅ 22	200	50	600	1155	1211	4	225	885	580	16	16	1701			
NCH200-500	250	200	132	315M	2029/LY4	2435	2071	170	350	1371	890	840	∅ 22	200	50	600	1155	1321	4	225	885	580	16	16	1815			
NCH200-500	250	200	160	315L	2029/MY5	2435	2071	170	350	1371	890	840	∅ 22	200	50	600	1155	1321	4	225	885	580	16	16	1965			
NCH200-500	250	200	200	315L	2029/IE4/MY5	2525	2161	170	350	1461	890	840	∅ 22	200	50	600	1155	1411	4	225	885	580	16	16	2030			
NCH200-500	250	200	250	355M	2026/NY5	2670	2215	170	350	1515	890	840	∅ 22	200	50	600	1201	1556	4	225	885	580	16	16	2442			
NCH200-500	250	200	315	355L	2026/PY5	2670	2215	170	350	1515	890	840	∅ 22	200	50	600	1201	1556	4	225	885	580	16	16	2632			
NC250-315	300	250	30	200L	1142/GY2	1673	1488	135	250	988	790	740	∅ 22	180	50	535	835	758	4	220	691	520	16	16	776			
NC250-315	300	250	37	225S	1143/GY2	1708	1505	135	250	1005	790	740	∅ 22	180	50	535	865	793	4	220	691	520	16	16	809			
NC250-315	300	250	45	225M	1144/HY2	1733	1530	135	250	1030	790	740	∅ 22	180	50	535	865	818	4	220	691	520	16	16	854			
NC250-315	300	250	55	250M	1145/HY2	1795	1558	135	250	1058	790	740	∅ 22	180	50	535	910	880	4	220	691	520	16	16	1025			
NC250-315	300	250	75	280S	1146/IY2	1928	1605	135	250	1105	790	740	∅ 22	180	50	535	930	1013	4	220	691	520	16	16	946			
NC250-400	300	250	75	280S	1147/IY2	1919	1596	135	250	1096	790	740	∅ 22	200	50	600	995	1013	4	220	682	560	16	16	1207			
NC250-400	300	250	90	280M	1148/IY2	1970	1647	135	250	1147	790	740	∅ 22	200	50	600	995	1064	4	220	682	560	16	16	1213			
NC250-400	300	250	110	315S	1149/LY2	2117	1723	135	300	1123	790	740	∅ 22	200	50	600	1155	1211	4	220	682	560	16	16	1499			
NC250-400	300	250	132	315M	1119/LY2	2227	1833	135	300	1233	790	740	∅ 22	200	50	600	1155	1321	4	220	682	560	16	16	1500			
NC250-400	300	250	160	315L	1119/LY2	2227	1833	135	300	1233	790	740	∅ 22	200	50	600	1155	1321	4	220	682	560	16	16	1650			
NC250-400	300	250	200	315L	1119/IE4/LY2	2317	1923	135	300	1323	790	740	∅ 22	200	50	600	1155	1411	4	220	682	560	16	16	1806			
NCH250-250	300	250	75	280S	2054/IY4	2127	1799	135	300	1199	760	710	∅ 22	180	50	535	930	1013	4	225	885	560	16	16	1136			
NCH250-500	300	250	160	315L	2024/MY5	2435	2071	170	350	1371	890	840	∅ 22	220	50	670	1225	1321	4	225	885	630	16	16	2075			
NCH250-500	300	250	200	315L	2024/IE4/MY5	2525	2161	170	350	1461	890	840	∅ 22	220	50	670	1225	1411	4	225	885	630	16	16	2163			
NCH250-500	300	250	250	355M	2040/NY5	2670	2165	170	350	1465	890	840	∅ 22	220	50	670	1271	1556	4	225	885	630	16	16	2605			
NCH250-500	300	250	315	355L	2040/PY5	2670	2235	170	350	1535	890	840	∅ 22	220	50	670	1271	1556	4	225	885	630	16	16	2795			
NCH250-500	300	250	355	355L	2040/PY5	2670	2235	170	350	1535	890	840	∅ 22	220	50	670	1271	1556	4	225	885	630	16	16	2810			

BGAN = Base and coupling
 * = Indicatives values according to the type of motor installed.
 ○ Motor in IE4 efficiency class according to EU REGULATION 2019/1781. Available in other efficiency classes for non-EU markets.

BGAN = Socle et accouplement
 * = Valeurs indicatives en fonction de la marque du moteur utilisé.
 ○ Moteur en classe de rendement IE4 conformément au RÉGLEMENT UE2019/1781. Disponibilité en différentes classes de rendement pour les marchés hors UE.

BGAN = Base e giunto
 * = Valori indicativi in funzione della marca di motore utilizzato.
 ○ Motore in classe di efficienza IE4 in conformità al REGOLAMENTO UE2019/1781. Disponibili in altre classi di efficienza per mercati extra UE.