



# MEC-MR

## 2200

n [min<sup>-1</sup>]

Operating data  
Caracteristiques de fonctionnement  
Caratteristiche di funzionamento

# caprari

DNa x DNm [mm]	Impeller Combinazione roues Combinazione giranti	Capacity / Debit / Portata										
		[l/m]	0	1200	1500	1800	2100	2400	3000	3600	4200	4740
		[m <sup>3</sup> /h]	0	72	90	108	126	144	180	216	252	284,4
		[l/s]	0	20	25	30	35	40	50	60	70	79

MEC-MR 100-1/2												
100 x 100	I	H P	124,5 -	121,6 42,3	120,2 47	117,8 51,7	114,2 56,3	109,9 60,6				
100 x 100	H	H P	134,6 -	133,3 46,6	132,3 52,1	130,3 57,6	127,1 62,9	123 68				
100 x 100	G	H P	143,3 -	142,8 50,7	141,9 56,6	140,1 62,3	136,8 67,9	132,2 73,3				
100 x 100	F	H P	153,6 -	151,8 54,8	150,8 60,9	148,9 67	145,7 73	141,4 78,8				
100 x 100	E	H P	167,4 -	164,9 61,5	163,8 68	161,8 74,5	158,7 80,8	154,6 87	144 99,2			
100 x 100	D	H P	178,4 -	176,3 67,9	175,3 75,1	173,5 82	170,7 88,8	167,1 95,4	157,2 108,5			
NPSH		[m]		2,7	3	3,5	4,2	5,3	9,2			

MEC-MR 100-2/2												
125 x 100	G	H P	145,3 -	144,2 62,7	143,2 68,5	141,6 74,2	139,4 79,9	132,2 91	119,4 102,3			
125 x 100	F	H P	154,9 -	155 68,6	154,4 74,8	153 81	150,6 87	143,1 98,7	131,6 110,4	116,1 121,2		
125 x 100	E	H P	171,1 -	168,5 77,7	168 84	166,3 90,2	163,8 96,4	156,7 108,9	146,2 121,3	132,3 133,2	117,5 142,4	
NPSH		[m]			2,5	2,5	2,6	2,8	3,6	4,8	6,8	9,2

H = Total manometric head at the bowl assembly in [m]  
P = Power absorbed by the bowl assembly in [kW]

N.B. Further to the pump type, please state as well the Impellers combination. (A,B,C, etc.)  
Ex.: MEC-MR...-I.A

H = Hauteur manométrique totale au corps de pompe en [m]  
P = Puissance absorbée par le corps de pompe en [kW]

N.B. Préciser s.v.p., non seulement le type de la pompe mais aussi la combinaison des roues. (A,B,C, etc.)  
Ex.: MEC-MR...-I.A

H = Prevalenza manometrica totale al corpo pompa in [m]  
P = Potenza assorbita dal corpo pompa in [kW]

N.B. Oltre alla pompa, precisare sempre anche il tipo della combinazione giranti. (A,B,C, ecc.)  
Es.: MEC-MR...-I.A

Overall dimensions and weights  
Dimensions d'encombrement et poids  
Dimensioni di ingombro e pesi

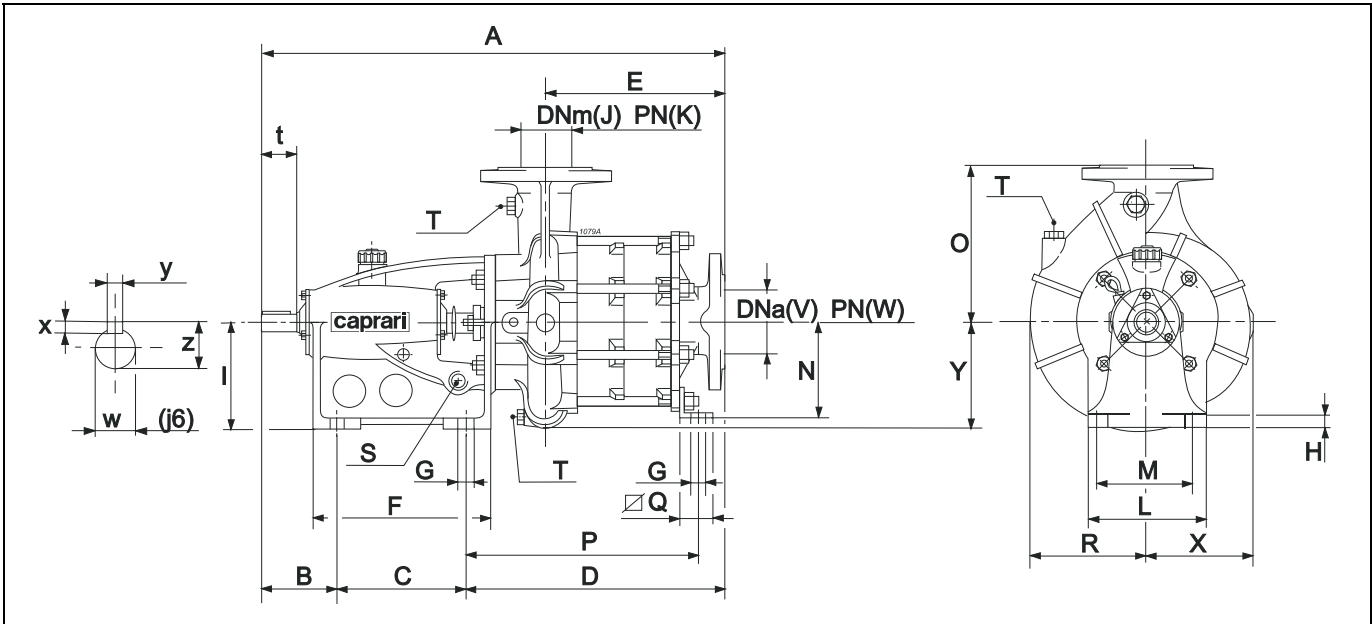

Type Type Tipo	Shaft projection Saille d'arbre Sporgenza d'albero	Weight Poids Peso [kg]	[mm]																										
			A	B	C	D	E	F	G	H	I	J	K	L	M	N	O	P	Q	R	S	T	V	W	X	Y			
MEC-MR65-2/3	2	116	794	152	240	402	275	330	22	19	200	65	25	215	180	160	275	369	45	188	G 3/8"	G 3/8"	80	16	168	180			
MEC-MR65-2/4	2	136	872	152	240	480	353	330	22	19	200	65	25	215	180	160	275	447	45	188	G 3/8"	G 3/8"	80	16	168	180			
MEC-MR65-3/2	1	81	615	124	185	306	197	255	19	16	160	65	16	180	150	-	275	-	-	188	G 3/8"	G 3/8"	80	10	168	180			
MEC-MR65-3/3	1	97	693	124	185	384	275	255	19	16	160	65	16	180	150	160	275	348	45	188	G 3/8"	G 3/8"	80	10	168	180			
MEC-MR80/2	2	127	769	152	240	377	250	330	22	19	200	80	16	215	180	-	325	-	-	244	G 3/8"	G 3/8"	100	16	222	223			
MEC-MR80/3	2	158	862	152	240	470	343	330	22	19	200	80	16	215	180	200	325	405	45	244	G 3/8"	G 3/8"	100	16	222	223			
MEC-MR80-1/2	2	136	739	152	240	347	220	330	22	19	200	80	16	215	180	-	325	-	-	244	G 3/8"	G 3/8"	80	16	222	223			
MEC-MR80-1/3	2	166	834	152	240	442	315	330	22	19	200	80	16	215	180	200	325	413	45	244	G 3/8"	G 3/8"	80	16	222	223			
MEC-MR80-2/2	2	133	769	152	240	377	250	330	22	19	200	80	16	215	180	-	325	-	-	244	G 3/8"	G 3/8"	100	16	222	223			
MEC-MR80-3/2	2	127	758	152	240	366	239	330	22	19	200	80	16	215	180	-	300	-	-	204	G 3/8"	G 3/8"	100	16	180	191			
MEC-MR80-4/3	2	158	862	152	240	470	343	330	22	19	200	80	16	215	180	200	325	405	45	244	G 3/8"	G 3/8"	100	16	222	223			
MEC-MR100/2	3	248	942	199	305	438	286	415	24	24	280	100	16	295	250	-	400	-	-	285	G 3/8"	G 3/8"	125	16	263	286			
MEC-MR100/3	3	312	1072	199	305	568	418	415	24	24	280	100	16	295	250	280	400	520	65	285	G 3/8"	G 3/8"	125	16	263	286			
MEC-MR100-1/2	3	253	942	199	305	438	286	415	24	24	280	100	16	295	250	-	400	-	-	285	G 3/8"	G 3/8"	100	16	263	286			
MEC-MR100-1/3	3	312	1072	199	305	568	418	415	24	24	280	100	16	295	250	280	400	523	65	285	G 3/8"	G 3/8"	100	16	263	286			
MEC-MR100-2/2	3	253	942	199	305	438	286	415	24	24	280	100	16	295	250	-	400	-	-	285	G 3/8"	G 3/8"	125	16	263	286			
MEC-MR100-2/3	3	312	1072	199	305	568	418	415	24	24	280	100	16	295	250	280	400	520	65	285	G 3/8"	G 3/8"	125	16	263	286			
MEC-MR125/2	3	264	949	199	305	445	295	415	24	24	280	125	16	295	250	-	425	-	-	303	G 3/8"	G 3/8"	150	16	270	294			
MEC-MR125/3	3	328	1079	199	305	575	425	415	24	24	280	125	16	295	250	280	425	525	65	303	G 3/8"	G 3/8"	150	16	270	286			

Type Type Tipo	Shaft projection Saille d'arbre Sporgenza d'albero				
	t	w	x	y	z
1	65	28	7	8	31
2	80	38	8	10	41
3	105	50	9	14	53,5

COUPLINGS WITH STANDARDIZED ENCLOSED ELECTRIC MOTORS  
 ACCOUPLEMENTS AVEC MOTEURS ÉLECTRIQUES FERMÉS NORMALISÉS  
 ACCOPIAMENTI CON MOTORI ELETTRICI CHIUSI NORMALIZZATI

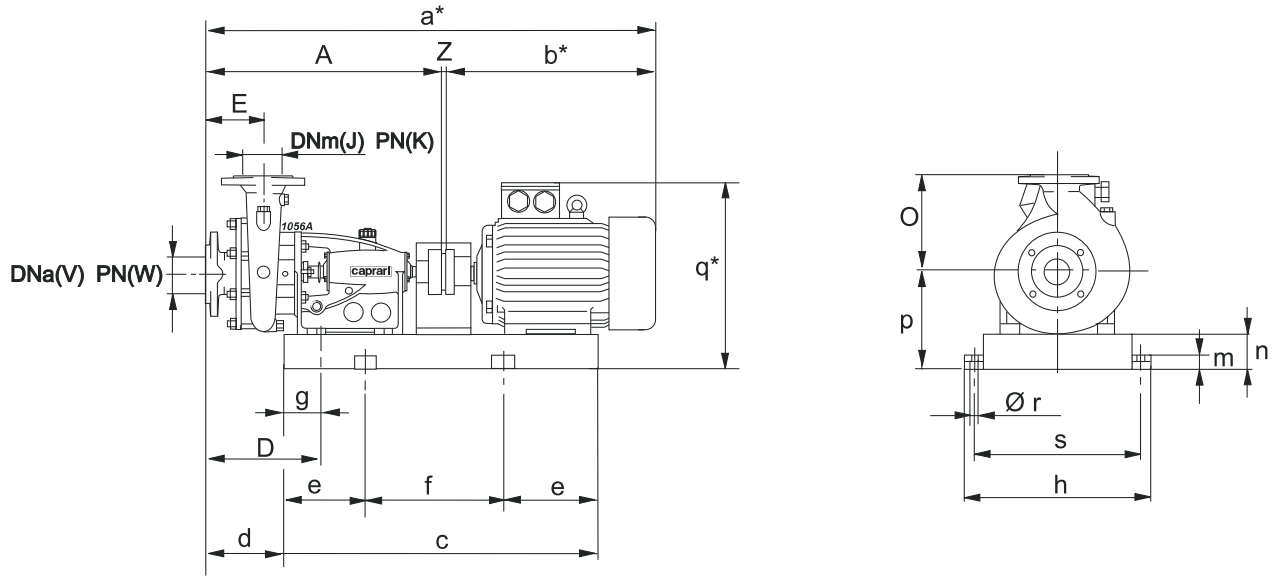

$d = D - g$

\*Valori indicativi in funzione della marca di motore utilizzato  
 Indicative values according to the type of motor installed

Pump Pompe Pompa	Motor Moteur Motore	Motor Moteur Motore	BGA	Weight Poids Peso	A	D	E	J	K	O	V	W	Z	a*	b*	c	e	f	g	h	m	n	p	q	r	s
Type Type Tipo	[kW]	Size Taille Grand.	Type Type Tipo	[kg]	[mm]																					
MEC-MR65-2/3	37	200L	95/4E	448	794	402	275	65	25	275	80	16	4	1536	738	1395	250	895	399	540	42	100	300	600	20	490
MEC-MR65-2/3	45	225M	100/4E	521	794	402	275	65	25	275	80	16	4	1573	775	1421	250	921	399	585	42	120	345	675	20	535
MEC-MR65-2/3	55	250M	62/5E	619	794	402	275	65	25	275	80	16	4	1668	870	1513	250	1013	399	635	42	120	370	745	20	585
MEC-MR65-2/3	75 ○	280S	61/5E	815	794	402	275	65	25	275	80	16	4	1798	1000	1560	250	1060	399	695	42	140	420	815	20	645
MEC-MR65-3/2	30	200L	41/4E	372	615	306	197	65	16	275	80	10	4	1357	738	973	150	673	60	540	42	100	300	600	20	490
MEC-MR65-3/2	37	200L	41/4E	400	615	306	197	65	16	275	80	10	4	1357	738	973	150	673	60	540	42	100	300	600	20	490
MEC-MR65-3/2	45	225M	14/4E	475	615	306	197	65	16	275	80	10	4	1394	775	1019	150	719	80	585	42	120	345	675	20	535
MEC-MR65-3/2	55	250M	34/5E	582	615	306	197	65	16	275	80	10	4	1489	870	1111	200	711	80	635	42	120	370	745	20	585
MEC-MR80-1/2	37	200L	37/4E	455	739	347	220	80	16	325	80	16	4	1481	738	1046	150	746	50	540	42	100	300	600	20	490
MEC-MR80-1/2	45	225M	24/4E	531	739	347	220	80	16	325	80	16	4	1518	775	1092	200	692	70	585	42	120	345	675	20	535
MEC-MR80-1/2	55	250M	23/5E	632	739	347	220	80	16	325	80	16	4	1613	870	1184	200	784	70	635	42	120	370	745	20	585
MEC-MR80-1/2	75 ○	280S	43/5E	818	739	347	220	80	16	325	80	16	4	1743	1000	1251	200	851	90	695	42	140	420	815	20	645
MEC-MR80-1/2	90 ○	280M	25/5E	898	739	347	220	80	16	325	80	16	4	1794	1051	1302	200	902	90	695	42	140	420	815	20	645
MEC-MR80-2/2	55	250M	23/5E	629	769	377	250	80	16	325	100	16	4	1643	870	1184	200	784	70	635	42	120	370	745	20	585
MEC-MR80-2/2	75 ○	280S	43/5E	815	769	377	250	80	16	325	100	16	4	1773	1000	1251	200	851	90	695	42	140	420	815	20	645
MEC-MR80-2/2	90 ○	280M	25/5E	895	769	377	250	80	16	325	100	16	4	1824	1051	1302	200	902	90	695	42	140	420	815	20	645
MEC-MR80-2/2	110 ○	315S	54/5E	910	769	377	250	80	16	325	100	16	4	1954	1181	1348	250	848	70	750	50	160	475	1030	22	700
MEC-MR80-3/2	37	200L	37/4E	446	758	366	239	80	16	300	100	16	4	1500	738	1046	150	746	50	540	42	100	300	600	20	490
MEC-MR80-3/2	45	225M	24/4E	522	758	366	239	80	16	300	100	16	4	1537	775	1092	200	692	70	585	42	120	345	675	20	535
MEC-MR80-3/2	55	250M	23/5E	623	758	366	239	80	16	300	100	16	4	1632	870	1184	200	784	70	635	42	120	370	745	20	585
MEC-MR80-3/2	75 ○	280S	43/5E	744	758	366	239	80	16	300	100	16	4	1762	1000	1251	200	851	90	695	42	140	420	815	20	645
MEC-MR80-3/2	90 ○	280M	25/5E	781	758	366	239	80	16	300	100	16	4	1813	1051	1302	200	902	90	695	42	140	420	815	20	645

BGA = Base and coupling

\* = Indicatives values according to the type of motor installed.

○ Motor in IE4 efficiency class according to EU REGULATION 2019/1781. Available in other efficiency classes for non-EU markets.

BGA = Socle et accouplement

\* = Valeurs indicatives en fonction de la marque du moteur utilisé.

○ Moteur en classe de rendement IE4 conformément au RÈGLEMENT UE2019/1781. Disponibilité en différentes classes de rendement pour les marchés hors UE.

BGA = Base e giunto

\* = Valori indicativi in funzione della marca di motore utilizzato.

○ Motore in classe di efficienza IE4 in conformità al REGOLAMENTO UE2019/1781. Disponibili in altre classi di efficienza per mercati extra UE.

Selection - dimensions and weights for base mounted electric pumps  
 Sélection - dimensions et poids des électropompes sur socle  
 Selezione - dimensioni e pesi elettropompe su base

COUPLINGS WITH STANDARDIZED ENCLOSED ELECTRIC MOTORS  
 ACCOUPLEMENTS AVEC MOTEURS ÉLECTRIQUES FERMÉS NORMALISÉS  
 ACCOPIAMENTI CON MOTORI ELETTRICI CHIUSI NORMALIZZATI

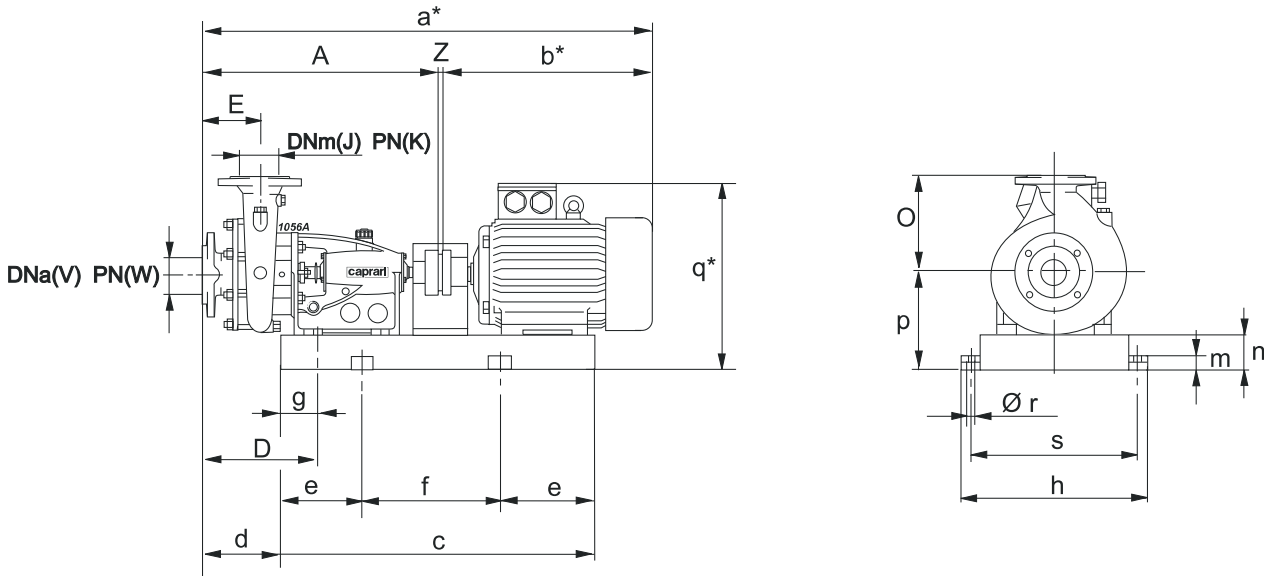

$d=D-g$

\*Valori indicativi in funzione della marca di motore utilizzato  
 Indicative values according to the type of motor installed

Pump Pompe Pompa	Motor Moteur Motore	Motor Moteur Motore	BGA	Weight Poids Peso	A	D	E	J	K	O	V	W	Z	a*	b*	c	e	f	g	h	m	n	p	q	r	s
Type Type Tipo	[kW]	Size Taille Grand.	Type Type Tipo	[kg]	[mm]																					
MEC-MR65-2/4	7,5	132M	262/3D	245	872	480	353	65	25	275	80	16	4	1366	490	1260	200	860	477	405	42	100	300	492	20	355
MEC-MR65-2/4	11	160M	264/3E	330	872	480	353	65	25	275	80	16	4	1503	627	1346	200	946	477	465	42	100	300	551	20	415
MEC-MR65-2/4	15	160L	69/4E	348	872	480	353	65	25	275	80	16	4	1503	627	1390	250	890	477	465	42	100	300	551	20	415
MEC-MR65-3/2	3	100L	10/2D	135	615	306	197	65	16	275	80	10	4	1024	405	654	100	454	40	350	38	80	240	390	16	300
MEC-MR65-3/2	4	112M	11/2D	145	615	306	197	65	16	275	80	10	4	1059	440	661	100	461	40	375	38	80	240	412	16	325
MEC-MR65-3/2	5,5	132S	12/2D	156	615	306	197	65	16	275	80	10	4	1074	455	702	100	502	40	405	38	80	240	432	16	355
MEC-MR65-3/2	7,5	132M	13/3D	168	615	306	197	65	16	275	80	10	4	1109	490	740	100	540	40	405	38	80	240	432	16	355
MEC-MR65-3/3	5,5	132S	265/2D	178	693	384	275	65	16	275	80	10	4	1152	455	1040	150	740	378	405	38	80	240	432	16	355
MEC-MR65-3/3	7,5	132M	74/3D	194	693	384	275	65	16	275	80	10	4	1187	490	1078	200	678	378	405	38	80	240	432	16	355
MEC-MR65-3/3	11	160M	93/3E	275	693	384	275	65	16	275	80	10	4	1324	627	1164	200	764	378	465	38	80	240	491	16	415
MEC-MR80/2	7,5	132M	18/3D	219	769	377	250	80	16	325	100	16	4	1263	490	833	150	533	50	405	42	100	300	492	20	355
MEC-MR80/2	11	160M	20/3E	313	769	377	250	80	16	325	100	16	4	1400	627	919	150	619	50	465	42	100	300	551	20	415
MEC-MR80/2	15	160L	21/4E	326	769	377	250	80	16	325	100	16	4	1400	627	963	150	663	50	465	42	100	300	551	20	415
MEC-MR80/2	18,5	180M	22/4E	368	769	377	250	80	16	325	100	16	4	1438	665	973	150	673	50	500	42	100	300	570	20	450
MEC-MR80/2	22	180L	42/4E	388	769	377	250	80	16	325	100	16	4	1478	705	1011	150	711	50	500	42	100	300	570	20	450
MEC-MR80/3	11	160M	266/3E	351	862	470	343	80	16	325	100	16	4	1493	627	1304	200	904	435	465	42	100	300	551	20	415
MEC-MR80/3	15	160L	267/4E	369	862	470	343	80	16	325	100	16	4	1493	627	1348	200	948	435	465	42	100	300	551	20	415
MEC-MR80/3	18,5	180M	99/4E	403	862	470	343	80	16	325	100	16	4	1531	665	1358	250	858	435	500	42	100	300	570	20	450
MEC-MR80/3	22	180L	94/4E	430	862	470	343	80	16	325	100	16	4	1571	705	1396	250	896	435	500	42	100	300	570	20	450
MEC-MR80/3	30	200L	71/5E	500	862	470	343	80	16	325	100	16	4	1624	758	1431	250	931	435	540	42	100	300	600	20	490
MEC-MR80/3	37	225S	282/5E	557	862	470	343	80	16	325	100	16	4	1659	793	1462	250	962	435	585	42	120	345	675	20	535
MEC-MR80/3	45	225M	281/5E	600	862	470	343	80	16	325	100	16	4	1684	818	1487	250	987	435	585	42	120	345	675	20	535
MEC-MR80-1/2	7,5	132M	18/3D	228	739	347	220	80	16	325	80	16	4	1233	490	833	150	533	50	405	42	100	300	492	20	355
MEC-MR80-1/2	11	160M	20/3E	322	739	347	220	80	16	325	80	16	4	1370	627	919	150	619	50	465	42	100	300	551	20	415
MEC-MR80-1/2	15	160L	21/4E	335	739	347	220	80	16	325	80	16	4	1370	627	963	150	663	50	465	42	100	300	551	20	415
MEC-MR80-1/2	18,5	180M	22/4E	377	739	347	220	80	16	325	80	16	4	1408	665	973	150	673	50	500	42	100	300	570	20	450
MEC-MR80-1/2	22	180L	42/4E	397	739	347	220	80	16	325	80	16	4	1448	705	1011	150	711	50	500	42	100	300	570	20	450
MEC-MR80-1/3	11	160M	268/3E	359	834	442	315	80	16	325	80	16	4	1465	627	1312	200	912	443	465	42	100	300	551	20	415
MEC-MR80-1/3	15	160L	269/4E	377	834	442	315	80	16	325	80	16	4	1465	627	1356	250	856	443	465	42	100	300	551	20	415
MEC-MR80-1/3	18,5	180M	96/4E	412	834	442	315	80	16	325	80	16	4	1503	665	1366	250	866	443	500	42	100	300	570	20	450
MEC-MR80-1/3	22	180L	270/4E	447	834	442	315	80	16	325	80	16	4	1543	705	1404	250	904	443	500	42	100	300	570	20	450
MEC-MR80-1/3	30	200L	60/5E	509	834	442	315	80	16	325	80	16	4	1596	758	1439	250	939	443	540	42	100	300	600	20	490
MEC-MR80-3/2	5,5	132S	17/3D	211	758	366	239	80	16	300	100	16	4	1217	455	795	150	495	50	405	42	100	300	492	20	355
MEC-MR80-3/2	7,5	132M	18/3D	219	758	366	239	80	16	300	100	16	4	1252	490	833	150	533	50	405	42	100	300	492	20	355

BGA = Base and coupling

BGA = Socle et accouplement

BGA = Base e giunto

\* = Indicatives values according to the type of motor installed.

\* = Valeurs indicatives en fonction de la marque du moteur utilisé.

\* = Valori indicativi in funzione della marca di motore utilizzato.

COUPLINGS WITH STANDARDIZED ENCLOSED ELECTRIC MOTORS  
 ACCOUPLEMENTS AVEC MOTEURS ÉLECTRIQUES FERMÉS NORMALISÉS  
 ACCOPPIAMENTI CON MOTORI ELETRICI CHIUSI NORMALIZZATI

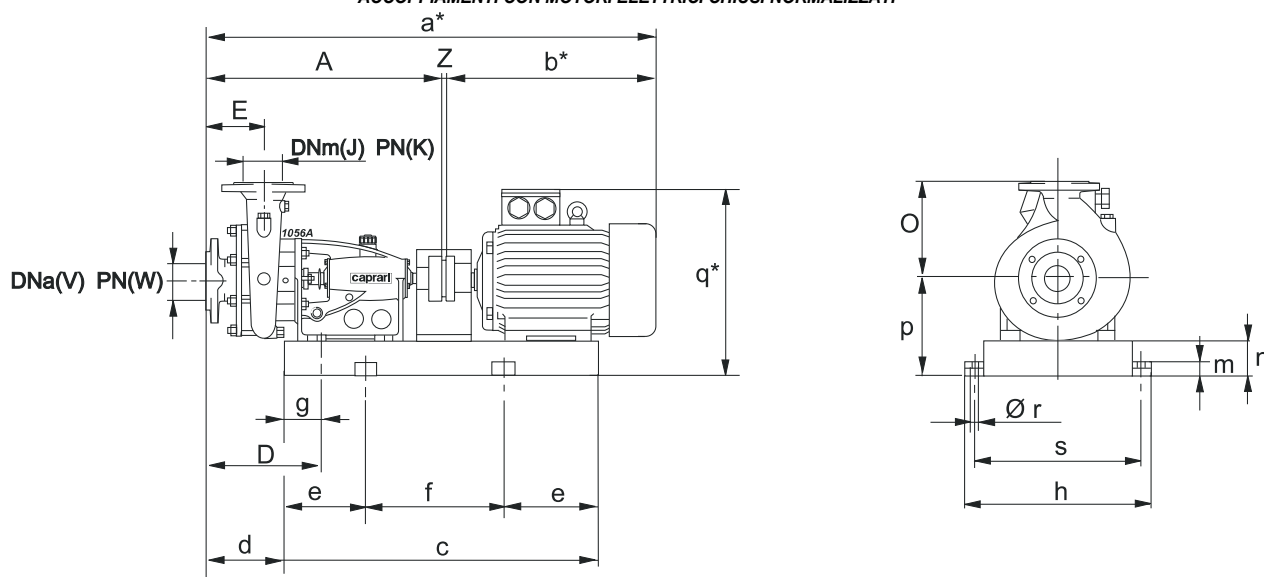

$d=D-g$

\*Valori indicativi in funzione della marca di motore utilizzato  
 Indicative values according to the type of motor installed

Pump Pompe Pompa	Motor Moteur Motore	Motor Moteur Motore	BGA	Weight Poids Peso	A	D	E	J	K	O	V	W	Z	a*	b*	c	e	f	g	h	m	n	p	q	r	s		
Type Type Tipo	[kW]	Size Taille Grand.	Type Type Tipo	[kg]	[mm]																							
MEC-MR80-3/2	11	160M	20/3E	313	758	366	239	80	16	300	100	16	4	1389	627	919	150	619	50	465	42	100	300	551	20	415		
MEC-MR80-3/2	15	160L	21/4E	326	758	366	239	80	16	300	100	16	4	1389	627	963	150	663	50	465	42	100	300	551	20	415		
MEC-MR80-4/3	37	225S	282/5E	557	862	470	343	80	16	325	100	16	4	1659	793	1462	250	962	435	585	42	120	345	675	20	535		
MEC-MR80-4/3	45	225M	281/5E	600	862	470	343	80	16	325	100	16	4	1684	818	1487	250	987	435	585	42	120	345	675	20	535		
MEC-MR100/2	22	180L	27/5F	545	942	438	286	100	16	400	125	16	4	1651	705	1153	200	753	65	490	42	140	420	690	20	440		
MEC-MR100/2	30	200L	28/5F	610	942	438	286	100	16	400	125	16	4	1704	758	1178	200	778	60	540	42	140	420	720	20	490		
MEC-MR100/2	37	225S	29/5K	657	942	438	286	100	16	400	125	16	4	1739	793	1199	200	799	60	585	42	140	420	750	20	535		
MEC-MR100/2	45	225M	30/5K	700	942	438	286	100	16	400	125	16	4	1764	818	1224	200	824	60	585	42	140	420	750	20	535		
MEC-MR100/2	55	250M	31/6K	837	942	438	286	100	16	400	125	16	4	1826	880	1286	200	886	60	635	42	140	420	795	20	585		
MEC-MR100/2	75 ○	280S	48/6K	988	942	438	286	100	16	400	125	16	4	1959	1013	1333	200	933	60	695	42	140	420	815	20	645		
MEC-MR100/3	37	225S	271/5K	750	1072	568	418	100	16	400	125	16	4	1869	793	1699	300	1099	560	585	42	140	420	750	20	535		
MEC-MR100/3	45	225M	80/5K	788	1072	568	418	100	16	400	125	16	4	1894	818	1724	300	1124	560	585	42	140	420	750	20	535		
MEC-MR100/3	55	250M	78/6K	926	1072	568	418	100	16	400	125	16	4	1956	880	1786	300	1186	560	635	42	140	420	795	20	585		
MEC-MR100/3	75 ○	280S	77/6K	1073	1072	568	418	100	16	400	125	16	4	2089	1013	1833	300	1233	560	695	42	140	420	815	20	645		
MEC-MR100/3	90 ○	280M	84/6K	1138	1072	568	418	100	16	400	125	16	4	2140	1064	1884	300	1284	560	695	42	140	420	815	20	645		
MEC-MR100-1/2	22	180L	27/5F	550	942	438	286	100	16	400	100	16	4	1651	705	1153	200	753	65	490	42	140	420	690	20	440		
MEC-MR100-1/2	30	200L	28/5F	615	942	438	286	100	16	400	100	16	4	1704	758	1178	200	778	60	540	42	140	420	720	20	490		
MEC-MR100-1/2	37	225S	29/5K	662	942	438	286	100	16	400	100	16	4	1739	793	1199	200	799	60	585	42	140	420	750	20	535		
MEC-MR100-1/2	45	225M	30/5K	705	942	438	286	100	16	400	100	16	4	1764	818	1224	200	824	60	585	42	140	420	750	20	535		
MEC-MR100-1/2	55	250M	31/6K	842	942	438	286	100	16	400	100	16	4	1826	880	1286	200	886	60	635	42	140	420	795	20	585		
MEC-MR100-1/3	30	200L	272/5F	753	1072	568	418	100	16	400	100	16	4	1834	758	1681	300	1081	563	540	42	140	420	720	20	490		
MEC-MR100-1/3	37	225S	273/5K	745	1072	568	418	100	16	400	100	16	4	1869	793	1702	300	1102	563	585	42	140	420	750	20	535		
MEC-MR100-1/3	45	225M	274/5K	788	1072	568	418	100	16	400	100	16	4	1894	818	1727	300	1127	563	585	42	140	420	750	20	535		
MEC-MR100-1/3	55	250M	275/6K	926	1072	568	418	100	16	400	100	16	4	1956	880	1789	300	1189	563	635	42	140	420	795	20	585		
MEC-MR100-1/3	75 ○	280S	276/6K	1073	1072	568	418	100	16	400	100	16	4	2089	1013	1836	300	1236	563	695	42	140	420	815	20	645		
MEC-MR100-1/3	90 ○	280M	277/6K	1138	1072	568	418	100	16	400	100	16	4	2140	1064	1887	300	1287	563	695	42	140	420	815	20	645		
MEC-MR100-2/2	37	225S	29/5K	662	942	438	286	100	16	400	125	16	4	1739	793	1199	200	799	60	585	42	140	420	750	20	535		
MEC-MR100-2/2	45	225M	30/5K	705	942	438	286	100	16	400	125	16	4	1764	818	1224	200	824	60	585	42	140	420	750	20	535		
MEC-MR100-2/2	55	250M	31/6K	842	942	438	286	100	16	400	125	16	4	1826	880	1286	200	886	60	635	42	140	420	795	20	585		
MEC-MR100-2/3	45	225M	274/5K	788	1072	568	418	100	16	400	125	16	4	1894	818	1727	300	1127	563	585	42	140	420	750	20	535		
MEC-MR100-2/3	55	250M	275/6K	926	1072	568	418	100	16	400	125	16	4	1956	880	1789	300	1189	563	635	42	140	420	795	20	585		
MEC-MR100-2/3	75 ○	280S	276/6K	1073	1072	568	418	100	16	400	125	16	4	2089	1013	1836	300	1236	563	695	42	140	420	815	20	645		
MEC-MR125/2	37	225S	29/5K	673	949	445	295	125	16	425	150	16	4	1746	793	1199	200	799	60	585	42	140	420	750	20	535		
MEC-MR125/2	45	225M	30/5K	716	949	445	295	125	16	425	150	16	4	1771	818	1224	200	824	60	585	42	140	420	750	20	535		

BGA = Base and coupling

\* = Indicative values according to the type of motor installed.

○ Motor in IE4 efficiency class according to EU REGULATION 2019/1781. Available in other efficiency classes for non-EU markets.

BGA = Socle et accouplement

\* = Valeurs indicatives en fonction de la marque du moteur utilisé.

○ Moteur en classe de rendement IE4 conformément au RÈGLEMENT UE2019/1781. Disponibilité en différentes classes de rendement pour les marchés hors UE.

BGA = Base e giunto

\* = Valori indicativi in funzione della marca di motore utilizzato.

○ Motore in classe di efficienza IE4 in conformità al REGOLAMENTO UE2019/1781. Disponibili in altre classi di efficienza per mercati extra UE.