

# PMA 80

3500 n [min<sup>-1</sup>]



Utilization field Champ d'utilisation Campo di utilizzo ≥ 65% η		
Stage number: compatibly with the maximum pressure. Nombre d'étages: compatible avec la pression maximum. Numero stadi: compatibilmente con la pressione massima di esercizio.		
Type Type Tipo	MIN.	MAX.
PMA	2	7
PMAS	2	7
PMAH	5	10
NB. For two-stage pumps only, reduce efficiency by one point. Diminuer le rendement d'un point seulement pour les pompes à deux étages. Solamente per le pompe a due stadi, ridurre di un punto il rendimento.		

Wet moment of inertia J Moment d'inertie J mouillé Momento d'inertzia J bagnato $J = \frac{1}{2}PD^2 - [kg\ m^2]$		
Impeller type Roue type Girante tipo	PMA(S/H)80/1	For each additional stage Pour chaque étage en plus Per ogni stadio in più
Cast iron Fonte Ghisa	0,0201	0,0170
Bronze Bronze Bronzo	0,0223	0,0188

Maximum permissible power Puissances maximums admissibles Massime potenze ammissibili	
Type Type Tipo	N/n MAX.
PMA	0,06
PMAS	0,06
PMAH	0,1
For seal limits and calculation formulas of the maximum permissible powers, see technical data section. Consulter la section Données techniques pour connaître les limites des joints et les formules pour le calcul des puissances maximales admises. Per i limiti tenute e le formule di calcolo delle massime potenze ammissibili, vedere sezione dati tecnici.	

## PERFORMANCES EACH INTERMEDIATE STAGE CARACTERISTIQUES POUR CHAQUE ETAGE PRESTAZIONI PER STADIO

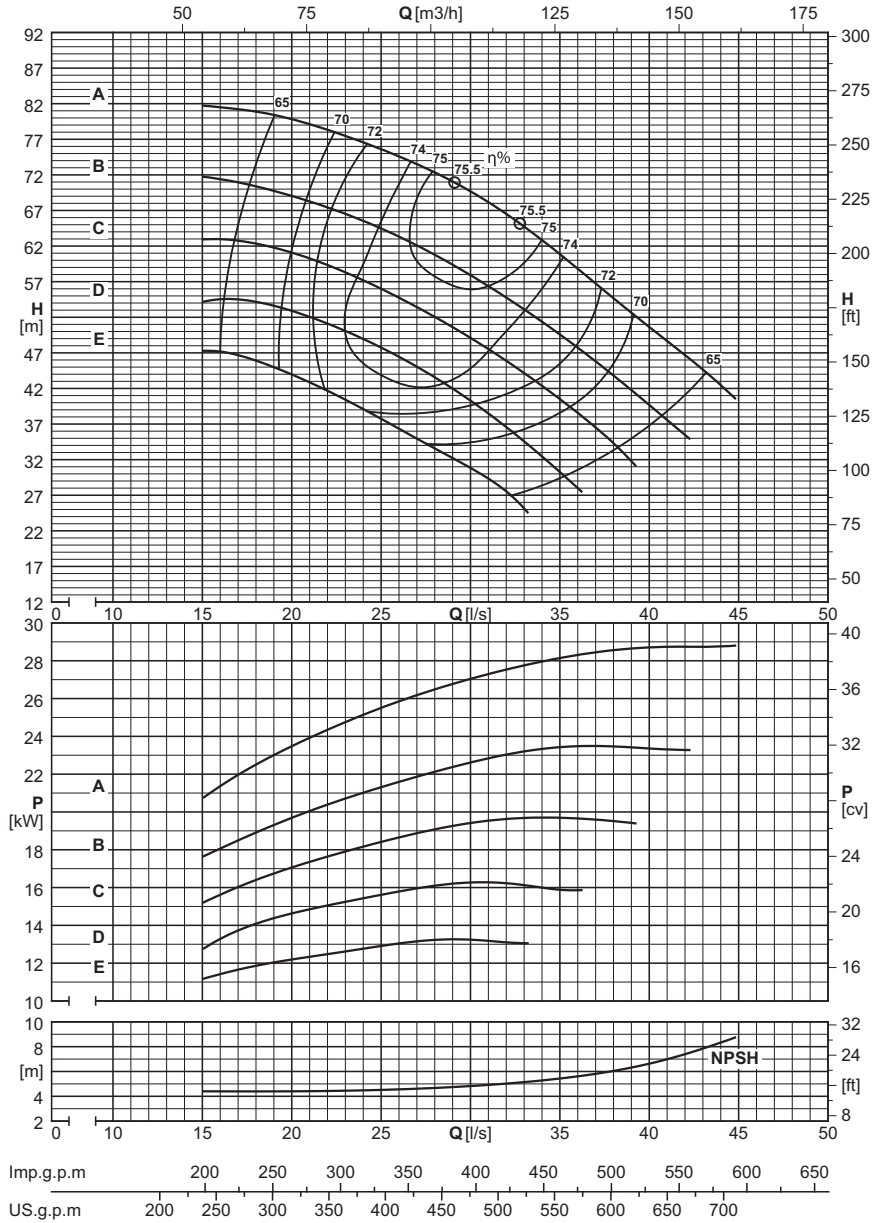

### Capacity - Debit - Portata

Dna x Dnm	Impeller type Roue type Girante tipo	[l/s]	0	14	16	18	20	22	24	26	28	30	32	34	36	38	40	42	44
		[m <sup>3</sup> /h]	0	50,4	57,6	64,8	72	79,2	86,4	93,6	100,8	108	115,2	122,4	129,6	136,8	144	151,2	158,4
		[l/min]	0	840	960	1080	1200	1320	1440	1560	1680	1800	1920	2040	2160	2280	2400	2520	2640

### PMA(S/H)80/1

125x80	E	[m]	49	51	47,5	46	44	41,5	40	36,5	33,5	30,5	27						
125x80	E	[kW]		10,4	11,4	11,9	12,3	12,6	12,9	13,2	13,1	13,1	13						
125x80	D	[m]	56	58	55	55	52	50	49	46,5	43,5	40,5	37	32,5					
125x80	D	[kW]		11,9	13,2	13,9	14,9	15	15,5	15,5	16	16,5	16,5						
125x80	C	[m]	65		64	61	61	58	57	55	52	49	46,5	42,5	39	34,5			
125x80	C	[kW]			15,5	16,5	17,5	18	18	18,5	19	19	20	19,5	20	19,5			
125x80	B	[m]	74		73	70	67	67	65	63	60	57	54	51	47,5	44	40,5	35	33,5
125x80	B	[kW]			17,5	19	20	20,5	21	21,5	22	23	23	23,5	23	23,5	24	23	24
125x80	A	[m]	88			81	79	76	77	74	71	70	66	62	59	54	50	47,5	43,5
125x80	A	[kW]				22,5	23,5	25	25	26	26,5	26,5	27,5	29	28,5	28	28,5	30	29

### NPSH

[m]		4,1	4,4	4,4	4,4	4,4	4,5	4,6	4,7	4,8	5	5,3	5,6	6	6,6	7,5	8,1
-----	--	-----	-----	-----	-----	-----	-----	-----	-----	-----	---	-----	-----	---	-----	-----	-----

Overall dimensions and weights  
 Dimensions d'encombrement et poids  
 Dimensioni di ingombro e pesi

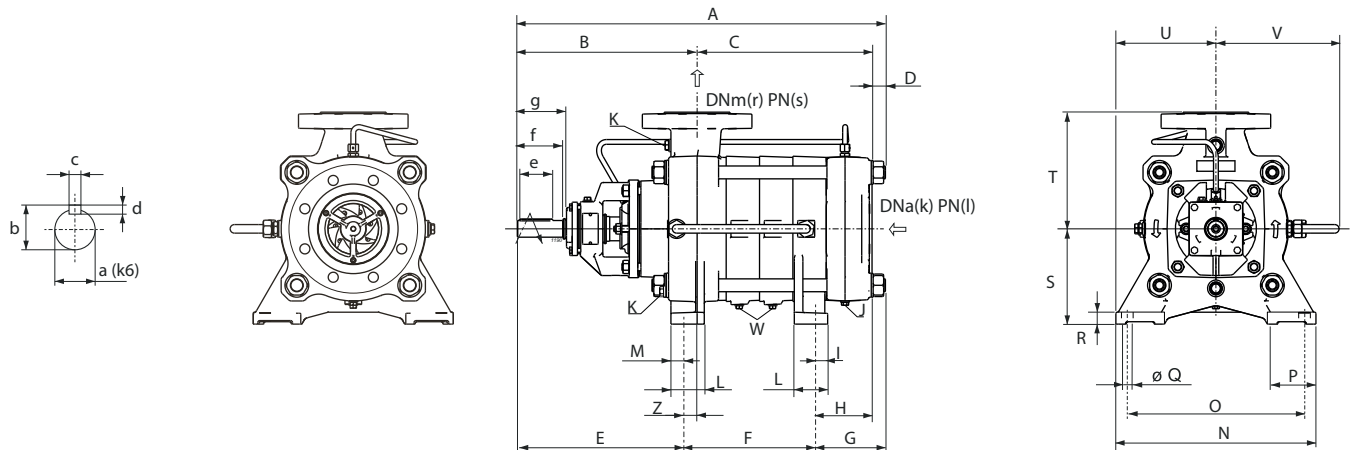

Series Série Serie	Type Type Tipo	A	B	C	D	E	F	G	H	S	T	U	V	Z	Weight Poids Peso
		[mm]													
PMA(S)	80/2	633	378	227	28	349	138	146	118	200	245	210	259	29	149
PMA(S)	80/3	703	378	297	28	349	208	146	118	200	245	210	259	29	170
PMA(S)	80/4	773	378	367	28	349	278	146	118	200	245	210	259	29	191
PMA(S/H)	80/5	843	378	437	28	349	348	146	118	200	245	210	259	29	212
PMA(S/H)	80/6	913	378	507	28	349	418	146	118	200	245	210	259	29	233
PMA(S/H)	80/7	983	378	577	28	349	488	146	118	200	245	210	259	29	254
PMA(S/H)	80/8	1053	378	647	28	349	558	146	118	200	245	210	259	29	275
PMA(S/H)	80/9	1123	378	717	28	349	628	146	118	200	245	210	259	29	296
PMA(S/H)	80/10	1193	378	787	28	349	698	146	118	200	245	210	259	29	317
PMA(S/H)	80/11	1263	378	857	28	349	768	146	118	200	245	210	259	29	338
PMA(S/H)	80/12	1333	378	927	28	349	838	146	118	200	245	210	259	29	359
PMA(S/H)	80/13	1403	378	997	28	349	908	146	118	200	245	210	259	29	380
PMA(S/H)	80/14	1473	378	1067	28	349	978	146	118	200	245	210	259	29	401
PMA(S/H)	80/15	1543	378	1137	28	349	1048	146	118	200	245	210	259	29	422
PMA(S/H)	80/16	1613	378	1207	28	349	1118	146	118	200	245	210	259	29	443

Foot dimensions Dimensions des pieds Dimensioni dei piedi							
I	L	M	N	O	P	Q	R
[mm]							
25	70	26	420	372	102	24,5	25

Shaft projection Saille d'arbre Sporgenza d'albero						
a	b	c	d	e	f	g
[mm]						
35	38	10	8	70	97	103

Flanges Brides Flange				
Type Type Tipo	(k) DNa	(l) PN	(r) DNm	(s) PN
	[mm]	[bar]	[mm]	[bar]
PMA	125	25	80	40
PMAS	125	25	80	63
PMAH	125	40	80	100

Plugs Bouchons Tappi		
J	K	W
G 1/4	G 1/2	G 1/4

Selection - dimensions and weights for base mounted electric pumps  
Sélection - dimensions et poids des électropompes sur socle  
Selezione - dimensioni e pesi elettropompe su base

COUPLINGS WITH STANDARDIZED ENCLOSED ELECTRIC MOTORS  
ACCOUPLMENTS AVEC MOTEURS ÉLECTRIQUES FERMÉS NORMALISÉS  
ACCOPIAMENTI CON MOTORI ELETTRICI CHIUSI NORMALIZZATI

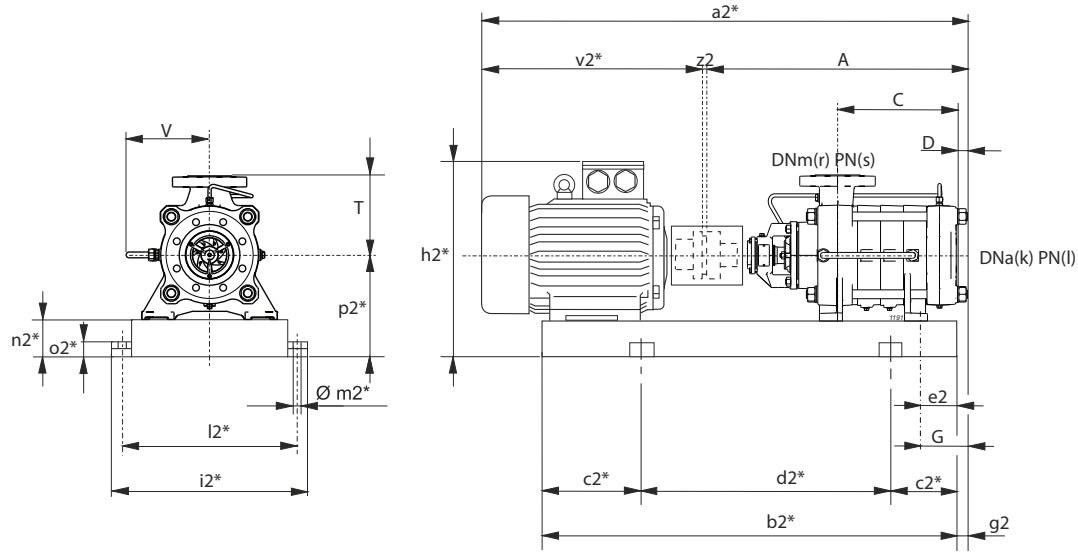

$g2 = G - e2$

\* Valori indicativi in funzione della marca di motore utilizzato  
Indicatives values according to the type of motor installed

Pump Pompe Pompa	Motor Moteur Motore	BGAMA	A	C	D	G	T	V	a2*	b2*	c2*	d2*	e2	h2*	i2*	k	l	l2*	m2*	n2*	o2*	p2*	r	s	v2*	z2	Weight Poids Peso		
Serie Série Serie	Type Type Tipo	[kW]	Size Taille Grand.	Type Type Tipo	[mm]																				[kg]				
PMA(S)	80/2	18,5	160L	615/DN	633	227	28	146	245	258,5	1264	1068	200	668	40	551	550	125	(1)	500	20	100	42	300	80	(2)	627	4	345
PMA(S)	/2	22	180M	616/EN	633	227	28	146	245	258,5	1302	1078	200	678	40	570	550	125	(1)	500	20	100	42	300	80	(2)	665	4	387
PMA(S)	/2	30	200L	617/FN	633	227	28	146	245	258,5	1375	1151	200	751	40	600	550	125	(1)	500	20	100	42	300	80	(2)	738	4	441
PMA(S)	/2	37	200L	617/FN	633	227	28	146	245	258,5	1375	1151	200	751	40	600	550	125	(1)	500	20	100	42	300	80	(2)	738	4	441
PMA(S)	80/3	30	200L	618/FN	703	297	28	146	245	258,5	1445	1221	200	821	40	600	550	125	(1)	500	20	100	42	300	80	(2)	738	4	464
PMA(S)	/3	37	200L	618/FN	703	297	28	146	245	258,5	1445	1221	200	821	40	600	550	125	(1)	500	20	100	42	300	80	(2)	738	4	464
PMA(S)	/3	45	225M	619/FN	703	297	28	146	245	258,5	1482	1277	200	877	70	675	585	125	(1)	535	20	120	42	345	80	(2)	775	4	568
PMA(S)	/3	55	250M	620/GN	703	297	28	146	245	258,5	1577	1339	200	939	60	745	635	125	(1)	585	20	120	42	370	80	(2)	870	4	658
PMA(S)	80/4	37	200L	621/FN	773	367	28	146	245	258,5	1515	1291	200	891	40	600	550	125	(1)	500	20	100	42	300	80	(2)	738	4	514
PMA(S)	/4	45	225M	622/FN	773	367	28	146	245	258,5	1552	1347	200	947	70	675	585	125	(1)	535	20	120	42	345	80	(2)	775	4	591
PMA(S)	/4	55	250M	623/GN	773	367	28	146	245	258,5	1647	1409	250	909	60	745	635	125	(1)	585	20	120	42	370	80	(2)	870	4	681
PMA(S)	/4	75	280S	624/HN	773	367	28	146	245	258,5	1777	1486	250	986	90	815	695	125	(1)	645	20	140	42	420	80	(2)	1000	4	902
PMA(S)	/4	90	280M	625/HN	773	367	28	146	245	258,5	1828	1537	250	1037	90	815	695	125	(1)	645	20	140	42	420	80	(2)	1051	4	1031
PMA(S/H)	80/5	45	225M	625/FN	843	437	28	146	245	258,5	1622	1417	250	917	70	675	585	125	(1)	535	20	120	42	345	80	(2)	775	4	614
PMA(S/H)	/5	55	250M	626/GN	843	437	28	146	245	258,5	1717	1479	250	979	60	745	635	125	(1)	585	20	120	42	370	80	(2)	870	4	704
PMA(S/H)	/5	75	280S	627/HN	843	437	28	146	245	258,5	1847	1556	250	1056	90	815	695	125	(1)	645	20	140	42	420	80	(2)	1000	4	925
PMA(S/H)	/5	90	280M	628/HN	843	437	28	146	245	258,5	1898	1607	250	1107	90	815	695	125	(1)	645	20	140	42	420	80	(2)	1051	4	1054
PMA(S/H)	80/6	55	250M	629/GN	913	507	28	146	245	258,5	1787	1549	250	1049	60	745	635	125	(1)	585	20	120	42	370	80	(2)	870	4	727
PMA(S/H)	/6	75	280S	630/HN	913	507	28	146	245	258,5	1917	1626	250	1126	90	815	695	125	(1)	645	20	140	42	420	80	(2)	1000	4	949
PMA(S/H)	/6	90	280M	631/HN	913	507	28	146	245	258,5	1968	1677	300	1077	90	815	695	125	(1)	645	20	140	42	420	80	(2)	1051	4	1077
PMA(S/H)	/6	110	315S	632/IN	913	507	28	146	245	258,5	2098	1723	300	1123	90	1030	780	125	(1)	730	22	160	50	475	80	(2)	1181	4	1370
PMA(S/H)	80/7	55	250M	633/GN	983	577	28	146	245	258,5	1857	1619	250	1119	60	745	635	125	(1)	585	20	120	42	370	80	(2)	870	4	750
PMA(S/H)	/7	75	280S	634/HN	983	577	28	146	245	258,5	1987	1696	300	1096	90	815	695	125	(1)	645	20	140	42	420	80	(2)	1000	4	972
PMA(S/H)	/7	90	280M	635/HN	983	577	28	146	245	258,5	2038	1747	300	1147	90	815	695	125	(1)	645	20	140	42	420	80	(2)	1051	4	1100
PMA(S/H)	/7	110	315S	636/IN	983	577	28	146	245	258,5	2168	1793	300	1193	90	1030	780	125	(1)	730	22	160	50	475	80	(2)	1181	4	1394
PMA(S/H)	/7	132	315M	637/IN	983	577	28	146	245	258,5	2278	1852	300	1252	90	1030	780	125	(1)	730	22	160	50	475	80	(2)	1291	4	1468
PMA(S/H)	80/8	75	280S	638/HN	1053	647	28	146	245	258,5	2057	1766	300	1166	90	815	695	125	(1)	645	20	140	42	420	80	(2)	1000	4	995
PMA(S/H)	/8	90	280M	639/HN	1053	647	28	146	245	258,5	2108	1817	300	1217	90	815	695	125	(1)	645	20	140	42	420	80	(2)	1051	4	1124
PMA(S/H)	/8	110	315S	640/IN	1053	647	28	146	245	258,5	2238	1863	300	1263	90	1030	780	125	(1)	730	22	160	50	475	80	(2)	1181	4	1417
PMA(S/H)	/8	132	315M	641/IN	1053	647	28	146	245	258,5	2348	1922	300	1322	90	1030	780	125	(1)	730	22	160	50	475	80	(2)	1291	4	1492
PMA(S/H)	/8	160	315L	642/LQ	1053	647	28	146	245	258,5	2348	1973	350	1273	90	1030	780	125	(1)	730	22	160	50	475	80	(2)	1291	4	1576
PMA(S/H)	/8	200	315L	642/IE4/LQ	1053	647	28	146	245	258,5	2438	2063	350	1363	198	1030	780	125	(1)	730	22	160	50	475	80	(2)	1381	4	1704

BGAMA = Base and coupling

\* = Indicatives values according to the type of motor installed

○ Motor in IE4 efficiency class according to EU REGULATION 2019/1781. Available in other efficiency classes for non-EU markets.

(1) PMA=25 bar PMAS=25 bar PMAH=40 bar

(2) PMA=40 bar PMAS=63 bar PMAH=100 bar

BGAMA = Socle et accouplement

\* = Valeurs indicatives en fonction de la marque du moteur utilisé

○ Moteur en classe de rendement IE4 conformément au RÈGLEMENT UE2019/1781. Disponibilité en différentes classes de rendement pour les marchés hors UE.

(1) PMA=25 bar PMAS=25 bar PMAH=40 bar

(2) PMA=40 bar PMAS=63 bar PMAH=100 bar

BGAMA = Base giunto e coprigiunto

\* = Valori indicativi in funzione della marca di motore utilizzato.

○ Motore in classe di efficienza IE4 in conformità al REGOLAMENTO UE2019/1781. Disponibili in altre classi di efficienza per mercati extra UE.

(1) PMA=25 bar PMAS=25 bar PMAH=40 bar

(2) PMA=40 bar PMAS=63 bar PMAH=100 bar

Selection - dimensions and weights for base mounted electric pumps  
*Sélection - dimensions et poids des électropompes sur socle*  
 Selezione - dimensioni e pesi elettropompe su base

COUPLINGS WITH STANDARDIZED ENCLOSED ELECTRIC MOTORS  
 ACCOUPLEMENTS AVEC MOTEURS ÉLECTRIQUES FERMÉS NORMALISÉS  
 ACCOPIAMENTI CON MOTORI ELETTRICI CHIUSI NORMALIZZATI

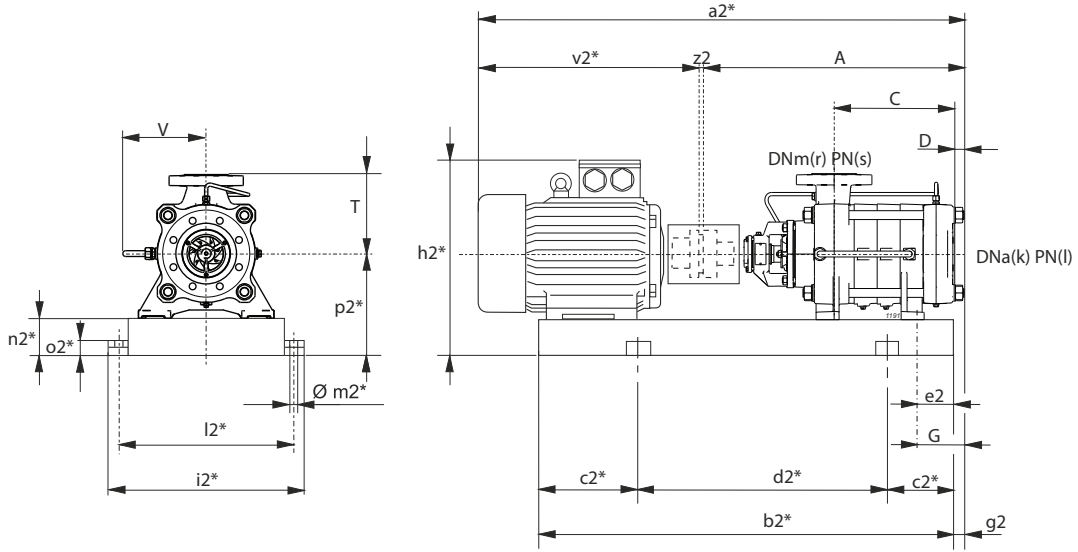

$g2 = G - e2$

\* Valori indicativi in funzione della marca di motore utilizzato  
*Indicatives values according to the type of motor installed*

Pump Pompe Pompa		Motor Moteur Motore		BGAMA	A	C	D	G	T	V	a2*	b2*	c2*	d2*	e2	h2*	i2*	k	l	l2*	m2*	n2*	o2*	p2*	r	s	v2*	z2	Weight Poids Peso	
Series Série Serie	Type Type Tipo	[kW]	Size Taille Grand.	Type Type Tipo	[mm]																									[kg]
PMA(S/H)	80/9	75	280S	643/HN	1123	717	28	146	245	258,5	2127	1836	300	1236	90	815	695	125	(1)	645	20	140	42	420	80	(2)	1000	4	1018	
PMA(S/H)	/9	90	280M	644/HN	1123	717	28	146	245	258,5	2178	1887	300	1287	90	815	695	125	(1)	645	20	140	42	420	80	(2)	1051	4	1147	
PMA(S/H)	/9	110	315S	645/IN	1123	717	28	146	245	258,5	2308	1933	300	1333	90	1030	780	125	(1)	730	22	160	50	475	80	(2)	1181	4	1441	
PMA(S/H)	/9	132	315M	646/IN	1123	717	28	146	245	258,5	2418	1992	350	1292	90	1030	780	125	(1)	730	22	160	50	475	80	(2)	1291	4	1515	
PMA(S/H)	/9	160	315L	647/LQ	1123	717	28	146	245	258,5	2418	2043	350	1343	90	1030	780	125	(1)	730	22	160	50	475	80	(2)	1291	4	1600	
PMA(S/H)	80/10	90	280M	648/HN	1193	787	28	146	245	258,5	2248	1957	350	1257	90	815	695	125	(1)	645	20	140	42	420	80	(2)	1051	4	1170	
PMA(S/H)	/10	110	315S	649/IN	1193	787	28	146	245	258,5	2378	2003	350	1303	90	1030	780	125	(1)	730	22	160	50	475	80	(2)	1181	4	1465	
PMA(S/H)	/10	132	315M	650/IN	1193	787	28	146	245	258,5	2488	2062	350	1362	90	1030	780	125	(1)	730	22	160	50	475	80	(2)	1291	4	1539	
PMA(S/H)	/10	160	315L	651/LQ	1193	787	28	146	245	258,5	2488	2113	350	1413	90	1030	780	125	(1)	730	22	160	50	475	80	(2)	1291	4	1623	
PMA(S/H)	/10	200	315L	651/IE4/LQ	1193	787	28	146	245	258,5	2578	2203	350	1503	198	1030	780	125	(1)	730	22	160	50	475	80	(2)	1381	4	1751	
PMA(S/H)	80/11	90	280M	6648/HN	1263	857	28	146	245	258,5	2318	2027	350	1327	90	815	695	125	(1)	645	20	140	42	420	80	(2)	1051	4	1193	
PMA(S/H)	/11	110	315S	1200/IS	1263	857	28	146	245	258,5	2448	2073	350	1373	90	1030	780	125	(1)	730	22	160	50	475	80	(2)	1181	4	1488	
PMA(S/H)	/11	132	315M	1201/IN	1263	857	28	146	245	258,5	2558	2132	350	1432	90	1030	780	125	(1)	730	22	160	50	475	80	(2)	1291	4	1563	
PMA(S/H)	/11	160	315L	1202/LQ	1263	857	28	146	245	258,5	2558	2183	350	1483	90	1030	780	125	(1)	730	22	160	50	475	80	(2)	1291	4	1647	
PMA(S/H)	/11	200	315L	1202/IE4/LQ	1263	857	28	146	245	258,5	2648	2273	400	1473	198	1030	780	125	(1)	730	22	160	50	475	80	(2)	1381	4	1775	
PMA(S/H)	80/12	110	315S	1203/IN	1333	927	28	146	245	258,5	2518	2143	350	1443	90	1030	780	125	(1)	730	22	160	50	475	80	(2)	1181	4	1512	
PMA(S/H)	/12	132	315M	1204/IN	1333	927	28	146	245	258,5	2628	2202	350	1502	90	1030	780	125	(1)	730	22	160	50	475	80	(2)	1291	4	1586	
PMA(S/H)	/12	160	315L	1205/LQ	1333	927	28	146	245	258,5	2628	2253	400	1453	90	1030	780	125	(1)	730	22	160	50	475	80	(2)	1291	4	1671	
PMA(S/H)	/12	200	315L	1205/IE4/LQ	1333	927	28	146	245	258,5	2718	2343	400	1543	198	1030	780	125	(1)	730	22	160	50	475	80	(2)	1381	4	1798	
PMA(S/H)	/12	250	355M	1206/LQ	1333	927	28	146	245	258,5	2863	2327	400	1527	110	1136	880	125	(1)	830	22	180	50	535	80	(2)	1526	4	2224	
PMA(H)	80/13	110	315S	2203/IN	1403	997	28	146	245	258,5	2588	2213	350	1513	90	1030	780	125	(1)	730	22	160	50	475	80	(2)	1181	4	1536	
PMA(H)	/13	160	315L	1207/IN	1403	997	28	146	245	258,5	2698	2323	400	1523	90	1030	780	125	(1)	730	22	160	50	475	80	(2)	1291	4	1690	
PMA(H)	/13	200	315L	1208/IE4/LQ	1403	997	28	146	245	258,5	2788	2413	400	1613	198	1030	780	125	(1)	730	22	160	50	475	80	(2)	1381	4	1822	
PMA(H)	/13	250	355M	1209/LQ	1403	997	28	146	245	258,5	2933	2397	400	1597	110	1136	880	125	(1)	830	22	180	50	535	80	(2)	1526	4	2248	
PMA(H)	80/14	160	315L	1210/IN	1473	1067	28	146	245	258,5	2768	2393	400	1593	90	1030	780	125	(1)	730	22	160	50	475	80	(2)	1291	4	1713	
PMA(H)	/14	200	315L	1211/IE4/LQ	1473	1067	28	146	245	258,5	2858	2483	400	1683	198	1030	780	125	(1)	730	22	160	50	475	80	(2)	1381	4	1846	
PMA(H)	/14	250	355M	1212/LQ	1473	1067	28	146	245	258,5	3003	2467	400	1667	110	1136	880	125	(1)	830	22	180	50	535	80	(2)	1526	4	2273	
PMA(H)	80/15	160	315L	1213/IN	1543	1137	28	146	245	258,5	2838	2463	400	1663	90	1030	780	125	(1)	730	22	160	50	475	80	(2)	1291	4	1737	
PMA(H)	/15	200	315L	1214/IE4/LQ	1543	1137	28	146	245	258,5	2928	2553	450	1653	198	1030	780	125	(1)	730	22	160	50	475	80	(2)	1381	4	1869	
PMA(H)	/15	280	355L	1215/LQ	1543	1137	28	146	245	258,5	3073	2607	450	1707	110	1136	880	125	(1)	830	22	180	50	535	80	(2)	1526	4	2425	
PMA(H)	80/16	160	315L	1216/IN	1613	1207	28	146	245	258,5	2908	2533	400	1733	90	1030	780	125	(1)	730	22	160	50	475	80	(2)	1291	4	1761	
PMA(H)	/16	200	315L	1217/IE4/LQ	1613	1207	28	146	245	258,5	2998	2623	450	1723	198	1030	780	125	(1)	730	22	160	50	475	80	(2)	1381	4	1893	
PMA(H)	/16	250	355M	1218/LQ	1613	1207	28	146	245	258,5	3143	2607	450	1707	110	1136	880	125	(1)	830	22	180	50	535	80	(2)	1526	4	2324	
PMA(H)	/16	315	355L	1218/MQ	1613	1207	28	146	245	258,5	3143	2677	450	1777	110	1136	880	125	(1)	830	22	180	50	535	80	(2)	1526	4	2453	

BGAMA = Base and coupling

\* = Indicatives values according to the type of motor installed

o Motor in IE4 efficiency class according to EU REGULATION 2019/1781. Available in other efficiency classes for non-EU markets.

- (1) PMA=25 bar PMAS=25 bar PMAH=40 bar
- (2) PMA=40 bar PMAS=63 bar PMAH=100 bar

BGAMA = Socle et accouplement

\* = Valeurs indicatives en fonction de la marque du moteur utilisé

o Moteur en classe de rendement IE4 conformément au REGLEMENT UE2019/1781. Disponibili in altre classi di efficienza per i mercati extra UE.

- (1) PMA=25 bar PMAS=25 bar PMAH=40 bar
- (2) PMA=40 bar PMAS=63 bar PMAH=100 bar

BGAMA = Base giunto e coprigiunto

\* = Valori indicativi in funzione della marca di motore utilizzato.

o Motore in classe di efficienza IE4 in conformità al REGOLAMENTO UE2019/1781. Disponibili in altre classi di efficienza per mercati extra UE.

- (1) PMA=25 bar PMAS=25 bar PMAH=40 bar
- (2) PMA=40 bar PMAS=63 bar PMAH=100 bar

Selection - dimensions and weights for base mounted electric pumps  
Sélection - dimensions et poids des électropompes sur socle  
Selezione - dimensioni e pesi elettropompe su base

COUPLINGS WITH STANDARDIZED ENCLOSED ELECTRIC MOTORS  
ACCOUPLMENTS AVEC MOTEURS ÉLECTRIQUES FERMÉS NORMALISÉS  
ACCOPIAMENTI CON MOTORI ELETTRICI CHIUSI NORMALIZZATI

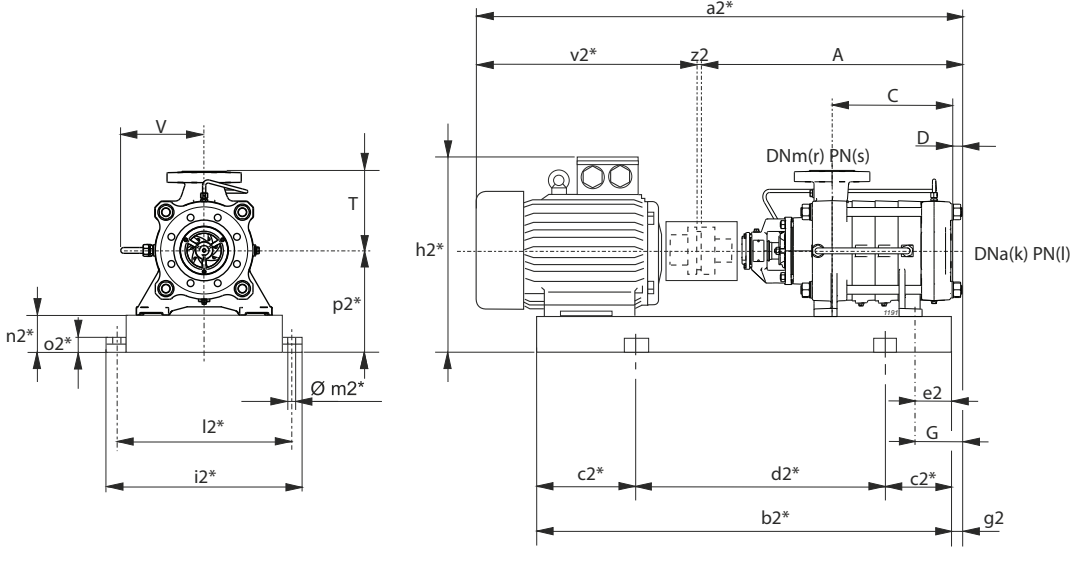

$g2 = G - e2$   
\* Valori indicativi in funzione della marca di motore utilizzato  
Indicatives values according to the type of motor installed

Pump Pompe Pompa		Motor Moteur Motore		BGAMA	A	C	D	G	T	V	a2*	b2*	c2*	d2*	e2	h2*	i2*	k	l	l2*	m2*	n2*	o2*	p2*	r	s	v2*	z2	Weight Poids Peso	
Series Série Serie	Type Type Tipo	[kW]	Size Taille Grand.	Type Type Tipo	[mm]																									[kg]
PMA(S)	80/2	2.2	100L	655/CN	633	227	28	146	245	258,5	1042	832	150	532	40	450	550	125	(1)	500	20	100	42	300	80	(2)	405	4	225	
PMA(S)	/2	3	100L	655/CN	633	227	28	146	245	258,5	1042	832	150	532	40	450	550	125	(1)	500	20	100	42	300	80	(2)	405	4	225	
PMA(S)	/2	4	112M	656/CN	633	227	28	146	245	258,5	1077	839	150	539	40	472	550	125	(1)	500	20	100	42	300	80	(2)	440	4	231	
PMA(S)	/2	5.5	132S	657/DN	633	227	28	146	245	258,5	1092	880	150	580	40	492	550	125	(1)	500	20	100	42	300	80	(2)	455	4	240	
PMA(S)	80/3	3	100L	6655/CN	703	297	28	146	245	258,5	1112	902	150	602	40	450	550	125	(1)	500	20	100	42	300	80	(2)	405	4	252	
PMA(S)	/3	4	112M	658/CN	703	297	28	146	245	258,5	1147	909	150	609	40	472	550	125	(1)	500	20	100	42	300	80	(2)	440	4	253	
PMA(S)	/3	5.5	132S	659/DN	703	297	28	146	245	258,5	1162	950	150	650	40	492	550	125	(1)	500	20	100	42	300	80	(2)	455	4	263	
PMA(S)	/3	7.5	132M	660/DN	703	297	28	146	245	258,5	1197	988	150	688	40	492	550	125	(1)	500	20	100	42	300	80	(2)	490	4	272	
PMA(S)	80/4	4	112M	6658/CN	773	367	28	146	245	258,5	1217	979	150	679	40	472	550	125	(1)	500	20	100	42	300	80	(2)	440	4	276	
PMA(S)	/4	5.5	132S	661/DN	773	367	28	146	245	258,5	1232	1020	150	720	40	492	550	125	(1)	500	20	100	42	300	80	(2)	455	4	285	
PMA(S)	/4	7.5	132M	662/DN	773	367	28	146	245	258,5	1267	1058	200	658	40	492	550	125	(1)	500	20	100	42	300	80	(2)	490	4	295	
PMA(S)	/4	11	160M	663/EN	773	367	28	146	245	258,5	1404	1164	200	764	40	551	550	125	(1)	500	20	100	42	300	80	(2)	627	4	381	
PMA(S/H)	80/5	5.5	132S	664/DN	843	437	28	146	245	258,5	1302	1090	200	690	40	492	550	125	(1)	500	20	100	42	300	80	(2)	455	4	308	
PMA(S/H)	/5	7.5	132M	665/DN	843	437	28	146	245	258,5	1337	1128	200	728	40	492	550	125	(1)	500	20	100	42	300	80	(2)	490	4	317	
PMA(S/H)	/5	11	160M	666/EN	843	437	28	146	245	258,5	1474	1234	200	834	40	551	550	125	(1)	500	20	100	42	300	80	(2)	627	4	403	
PMA(S/H)	/5	15	160L	667/EN	843	437	28	146	245	258,5	1474	1278	200	878	40	551	550	125	(1)	500	20	100	42	300	80	(2)	627	4	416	
PMA(S/H)	80/6	7.5	132M	668/DN	913	507	28	146	245	258,5	1407	1198	200	798	40	492	550	125	(1)	500	20	100	42	300	80	(2)	490	4	340	
PMA(S/H)	/6	11	160M	669/EN	913	507	28	146	245	258,5	1544	1304	200	904	40	551	550	125	(1)	500	20	100	42	300	80	(2)	627	4	426	
PMA(S/H)	/6	15	160L	670/EN	913	507	28	146	245	258,5	1544	1348	200	948	40	551	550	125	(1)	500	20	100	42	300	80	(2)	627	4	438	
PMA(S/H)	80/7	7.5	132M	671/DN	983	577	28	146	245	258,5	1477	1268	200	868	40	492	550	125	(1)	500	20	100	42	300	80	(2)	490	4	362	
PMA(S/H)	/7	11	160M	672/EN	983	577	28	146	245	258,5	1614	1374	250	874	40	551	550	125	(1)	500	20	100	42	300	80	(2)	627	4	448	
PMA(S/H)	/7	15	160L	673/EN	983	577	28	146	245	258,5	1614	1418	250	918	40	551	550	125	(1)	500	20	100	42	300	80	(2)	627	4	461	
PMA(S/H)	/7	18.5	180M	674/FN	983	577	28	146	245	258,5	1652	1428	250	928	40	570	550	125	(1)	500	20	100	42	300	80	(2)	665	4	498	
PMA(S/H)	80/8	11	160M	676/EN	1053	647	28	146	245	258,5	1684	1444	250	944	40	551	550	125	(1)	500	20	100	42	300	80	(2)	627	4	470	
PMA(S/H)	/8	15	160L	677/EN	1053	647	28	146	245	258,5	1684	1488	250	988	40	551	550	125	(1)	500	20	100	42	300	80	(2)	627	4	483	
PMA(S/H)	/8	18.5	180M	678/FN	1053	647	28	146	245	258,5	1722	1498	250	998	40	570	550	125	(1)	500	20	100	42	300	80	(2)	665	4	521	
PMA(S/H)	80/9	11	160M	679/EN	1123	717	28	146	245	258,5	1754	1514	250	1014	40	551	550	125	(1)	500	20	100	42	300	80	(2)	627	4	493	
PMA(S/H)	/9	15	160L	680/EN	1123	717	28	146	245	258,5	1754	1558	250	1058	40	551	550	125	(1)	500	20	100	42	300	80	(2)	627	4	506	
PMA(S/H)	/9	18.5	180M	681/FN	1123	717	28	146	245	258,5	1792	1568	250	1068	40	570	550	125	(1)	500	20	100	42	300	80	(2)	665	4	543	
PMA(S/H)	/9	22	180L	682/FN	1123	717	28	146	245	258,5	1832	1606	250	1106	40	570	550	125	(1)	500	20	100	42	300	80	(2)	705	4	564	
PMA(S/H)	80/10	11	160M	683/EN	1193	787	28	146	245	258,5	1824	1584	250	1084	40	551	550	125	(1)	500	20	100	42	300	80	(2)	627	4	515	
PMA(S/H)	/10	15	160L	684/EN	1193	787	28	146	245	258,5	1824	1628	250	1128	40	551	550	125	(1)	500	20	100	42	300	80	(2)	627	4	528	
PMA(S/H)	/10	18.5	180M	685/FN	1193	787	28	146	245	258,5	1862	1638	250	1138	40	570	550	125	(1)	500	20	100	42	300	80	(2)	665	4	566	
PMA(S/H)	/10	22	180L	686/FN	1193	787	28	146	245	258,5	1902	1676	300	1076	40	570	550	125	(1)	500	20	100	42	300	80	(2)	705	4	586	
PMA(S/H)	/10	30	200L	687/GN	1193	787	28	146	245	258,5	1955	1711	300	1111	40	600	550	125	(1)	500	20	100	42	300	80	(2)	758	4	648	

BGAMA = Base and coupling

\* = Indicatives values according to the type of motor installed

(1) PMA=25 bar PMAS=25 bar PMAH=40 bar

(2) PMA=40 bar PMAS=63 bar PMAH=100 bar

BGAMA = Socle et accouplement

\* = Valeurs indicatives en fonction de la marque du moteur utilisé

(1) PMA=25 bar PMAS=25 bar PMAH=40 bar

(2) PMA=40 bar PMAS=63 bar PMAH=100 bar

BGAMA = Base giunto e coprigiunto

\* = Valori indicativi in funzione della marca di motore utilizzato.

(1) PMA=25 bar PMAS=25 bar PMAH=40 bar

(2) PMA=40 bar PMAS=63 bar PMAH=100 bar

Selection - dimensions and weights for base mounted electric pumps  
 Sélection - dimensions et poids des électropompes sur socle  
 Selezione - dimensioni e pesi elettropompe su base

COUPLINGS WITH STANDARDIZED ENCLOSED ELECTRIC MOTORS  
 ACCOUPLEMENTS AVEC MOTEURS ÉLECTRIQUES FERMÉS NORMALISÉS  
 ACCOPIAMENTI CON MOTORI ELETTRICI CHIUSI NORMALIZZATI

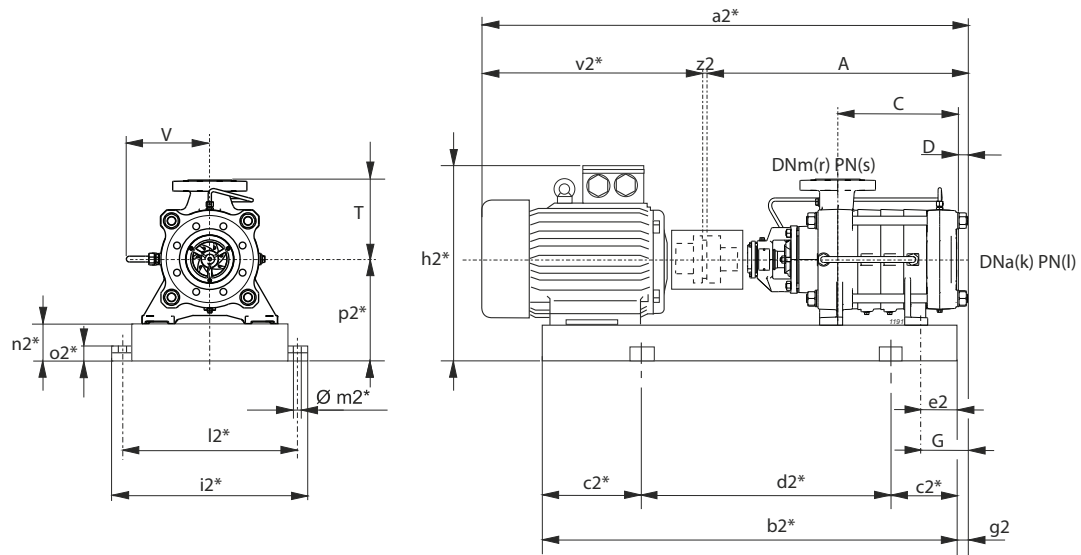

$g2 = G - e2$

\* Valori indicativi in funzione della marca di motore utilizzato  
 Indicatives values according to the type of motor installed

Pump Pompe Pompa	Motor Moteur Motore	BGAMA	A	C	D	G	T	V	a2*	b2*	c2*	d2*	e2	h2*	i2*	k	l	l2*	m2*	n2*	o2*	p2*	r	s	v2*	z2	Weight Poids Peso		
Series Série Serie	Type Type Tipo	[kW]	Size Taille Grand.	Type Type Tipo	[mm]																				[kg]				
PMA(S/H)	80/11	15	160L	688/EN	1263	857	28	146	245	258,5	1894	1698	300	1098	40	551	550	125	(1)	500	20	100	42	300	80	(2)	627	4	551
PMA(S/H)	/11	18,5	180M	689/FN	1263	857	28	146	245	258,5	1932	1708	300	1108	40	570	550	125	(1)	500	20	100	42	300	80	(2)	665	4	588
PMA(S/H)	/11	22	180L	690/FN	1263	857	28	146	245	258,5	1972	1746	300	1146	40	570	550	125	(1)	500	20	100	42	300	80	(2)	705	4	609
PMA(S/H)	/11	30	200L	691/GN	1263	857	28	146	245	258,5	2025	1781	300	1181	40	600	550	125	(1)	500	20	100	42	300	80	(2)	758	4	671
PMA(S/H)	80/12	15	160L	692/EN	1333	927	28	146	245	258,5	1964	1768	300	1168	40	551	550	125	(1)	500	20	100	42	300	80	(2)	627	4	573
PMA(S/H)	/12	18,5	180M	693/FN	1333	927	28	146	245	258,5	2002	1778	300	1178	40	570	550	125	(1)	500	20	100	42	300	80	(2)	665	4	610
PMA(S/H)	/12	22	180L	694/FN	1333	927	28	146	245	258,5	2042	1816	300	1216	40	570	550	125	(1)	500	20	100	42	300	80	(2)	705	4	631
PMA(S/H)	/12	30	200L	695/GN	1333	927	28	146	245	258,5	2095	1851	300	1251	40	600	550	125	(1)	500	20	100	42	300	80	(2)	758	4	693
PMA(S/H)	80/13	15	160L	1230/GN	1403	997	28	146	245	258,5	2034	1838	300	1238	40	551	550	125	(1)	500	20	100	42	300	80	(2)	627	4	598
PMA(S/H)	/13	18,5	180M	1231/FN	1403	997	28	146	245	258,5	2072	1848	300	1248	40	570	550	125	(1)	500	20	100	42	300	80	(2)	665	4	633
PMA(S/H)	/13	22	180L	1232/FN	1403	997	28	146	245	258,5	2112	1886	300	1286	40	570	550	125	(1)	500	20	100	42	300	80	(2)	705	4	654
PMA(S/H)	/13	30	200L	1233/FN	1403	997	28	146	245	258,5	2165	1921	300	1321	40	600	550	125	(1)	500	20	100	42	300	80	(2)	758	4	716
PMA(S/H)	80/14	15	160L	1234/EN	1473	1067	28	146	245	258,5	2104	1908	300	1308	40	551	550	125	(1)	500	20	100	42	300	80	(2)	627	4	618
PMA(S/H)	/14	18,5	180M	1235/FN	1473	1067	28	146	245	258,5	2142	1918	300	1318	40	570	550	125	(1)	500	20	100	42	300	80	(2)	665	4	655
PMA(S/H)	/14	22	180L	1236/FN	1473	1067	28	146	245	258,5	2182	1956	350	1256	40	570	550	125	(1)	500	20	100	42	300	80	(2)	705	4	676
PMA(S/H)	/14	30	200L	1237/GN	1473	1067	28	146	245	258,5	2235	1991	350	1291	40	600	550	125	(1)	500	20	100	42	300	80	(2)	758	4	738
PMA(S/H)	/14	37	225S	1238/HQ	1473	1067	28	146	245	258,5	2270	2052	350	1352	70	675	585	125	(1)	535	20	120	42	345	80	(2)	793	4	808
PMA(S/H)	80/15	15	160L	2234/EN	1543	1137	28	146	245	258,5	2174	1978	350	1278	40	551	550	125	(1)	500	20	100	42	300	80	(2)	627	4	641
PMA(S/H)	/15	18,5	180M	1239/FN	1543	1137	28	146	245	258,5	2212	1988	350	1288	40	570	550	125	(1)	500	20	100	42	300	80	(2)	665	4	678
PMA(S/H)	/15	22	180L	1240/FN	1543	1137	28	146	245	258,5	2252	2026	350	1326	40	570	550	125	(1)	500	20	100	42	300	80	(2)	705	4	699
PMA(S/H)	/15	30	200L	1241/GN	1543	1137	28	146	245	258,5	2305	2061	350	1361	40	600	550	125	(1)	500	20	100	42	300	80	(2)	758	4	761
PMA(S/H)	/15	37	225S	1242/HQ	1543	1137	28	146	245	258,5	2340	2122	350	1422	70	675	585	125	(1)	535	20	120	42	345	80	(2)	793	4	831
PMA(S/H)	80/16	18,5	180M	1243/FN	1613	1207	28	146	245	258,5	2282	2058	350	1358	40	570	550	125	(1)	500	20	100	42	300	80	(2)	665	4	700
PMA(S/H)	/16	22	180L	1244/FN	1613	1207	28	146	245	258,5	2322	2096	350	1396	40	570	550	125	(1)	500	20	100	42	300	80	(2)	705	4	721
PMA(S/H)	/16	30	200L	1245/GN	1613	1207	28	146	245	258,5	2375	2131	350	1431	40	600	550	125	(1)	500	20	100	42	300	80	(2)	758	4	783
PMA(S/H)	/16	37	225S	1246/HQ	1613	1207	28	146	245	258,5	2410	2192	350	1492	70	675	585	125	(1)	535	20	120	42	345	80	(2)	793	4	854

BGAMA = Base and coupling

\* = Indicatives values according to the type of motor installed

(1) PMA=25 bar PMAS=25 bar PMAH=40 bar

(2) PMA=40 bar PMAS=63 bar PMAH=100 bar

BGAMA = Socle et accouplement

\* = Valeurs indicatives en fonction de la marque du moteur utilisé

(1) PMA=25 bar PMAS=25 bar PMAH=40 bar

(2) PMA=40 bar PMAS=63 bar PMAH=100 bar

BGAMA = Base giunto e coprigiunto

\* = Valori indicativi in funzione della marca di motore utilizzato.

(1) PMA=25 bar PMAS=25 bar PMAH=40 bar

(2) PMA=40 bar PMAS=63 bar PMAH=100 bar